





LINHA BOX TRUSS

CATÁLOGO 2023

PERFISUD.COM.BR

  @perfisud

PERFISUD
EXTRUSÃO DE ALUMÍNIO



Localizada na cidade de Gravatal, Santa Catarina a **PERFISUD** atende a demanda de extrusão de alumínio, desde 2007, com eficiência e comprometimento.

A PERFISUD conta com 2 prensas de 5' e 1 de 7', tendo uma capacidade instalada de 1.500 ton/mês.

No ano de 2021, a PERFISUD inaugurou uma unidade de pintura eletrostática, a **COLORSUD**. Uma linha *Power Free* moderna, inovadora e altamente tecnológica. Com laboratório próprio, atendendo todas as normas para a garantia do processo e qualidade do serviço prestado. A COLORSUD tem como parceiros os melhores fornecedores, homologados **Qualicoat**.

Tudo isso para lhe entregar um produto altamente qualificado e seguro, que com certeza irá superar suas expectativas.

PERFISUD
EXTRUSÃO DE ALUMÍNIO

Missão

Atuar no mercado de alumínio com responsabilidade, qualidade e pontualidade na busca da melhor solução para todos.

Visão

Ser referência em qualidade e atendimento criando cada vez mais oportunidades de negócio até 2025.

Valores

Flexibilidade, Honestidade, Inovação e Responsabilidade.

COLORSUD
TECNOLOGIA EM PINTURA



PERFIS "U"

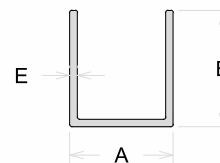

CÓDIGO	MILIMETROS			POLEGADAS			PESO (Kg/m)
	A	B	E	A	B	E	
BX-064	14,00	22,00	1,20	-	-	-	0,162
CX-900	29,00	17,50	1,50	-	-	1/16	0,247
CX-901	26,00	13,00	1,50	-	-	1/16	0,198
PAL-010	15,50	25,00	1,20	-	-	-	0,196
PAL-010L	15,00	25,00	0,90	-	-	-	0,157
PAL-011	15,50	25,00	1,20	-	-	-	0,188
PAL-024	15,60	48,00	1,80	-	-	-	0,527
PAL-025	14,40	48,00	1,20	-	-	-	0,350
PAL-054	11,00	20,00	1,20	-	-	-	0,128
PAL-067	13,80	22,00	1,00	-	-	-	0,143
PAL-540	11,00	22,00	1,20	-	-	-	0,140
PU-002	12,70	12,70	1,50	1/2	1/2	1/16	0,142
PU-003	9,52	9,52	1,10	3/8	3/8	-	0,142
PU-004	15,87	15,87	1,20	5/8	5/8	-	0,147
PU-005	11,00	15,00	1,10	-	-	-	0,115
PU-006	38,00	38,00	1,50	1.1/2	1.1/2	1/16	0,450
PU-014	14,00	15,00	1,10	-	-	-	0,125
PU-015	12,70	15,87	1,59	1/2	5/8	1/16	0,177
PU-019	29,00	19,00	1,50	-	-	1/16	0,259
PU-025	50,80	25,40	3,17	2	1	1/8	0,821
PU-035	35,30	40,00	2,50	-	-	-	0,686
PU-038	9,52	12,70	1,59	3/8	1/2	1/16	0,136
PU-047	29,00	35,00	1,50	-	1.3/8	-	0,390
PU-207	19,05	12,70	1,58	3/4	1/2	1/16	0,177
U-036	9,50	9,50	1,58	3/8	3/8	1/16	0,108
U-639	29,00	35,00	1,50	-	1.3/8	1/16	0,390
U-901	18,00	15,00	1,00	-	-	-	0,125
U-902	29,00	16,00	1,00	-	-	-	0,160
U-903	25,40	12,70	3,18	1	1/2	1/8	0,382
U-904	13,30	11,00	1,00	-	-	-	0,090

CANTONEIRAS

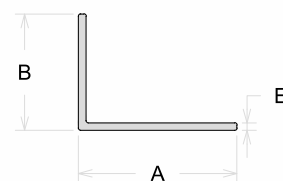

CÓDIGO	MILIMETROS			POLEGADAS			PESO (Kg/m)
	A	B	E	A	B	E	
BK-879	90,40	45,20	6,00	RAIO			2,148
BK-883	65,00	55,20	5,00	RAIO			1,589
CD-001	20,00	13,00	2,50	-	-	-	0,208
CD-002	50,00	30,00	3,00	-	-	-	0,625
CD-003	50,80	38,10	3,17	2	1.1/2	1/8	0,737
CD-004	50,00	75,00	4,50	C/ RANHURA			1,427
CD-006	50,00	25,00	1,50	-	-	1/16	0,299
CD-007	25,40	12,70	3,17	1	1/2	1/8	0,300
CD-008	50,00	43,00	4,30	-	-	-	1,037
CD-100	100,00	34,00	10,00	-	-	-	3,344
CD-108	108,00	51,00	4,76	-	-	3/16	1,996
CT-001	12,70	12,70	1,58	1/2	1/2	1/16	0,102
CT-002	15,90	15,90	3,20	5/8	5/8	1/8	0,246
CT-005	15,87	15,87	1,20	5/8	5/8	-	0,100
CT-007	19,05	19,05	1,20	3/4	3/4	-	0,120
CT-016	25,40	25,40	1,59	1	1	1/16	0,212
CT-016L	25,40	25,40	1,20	1	1	-	0,161
CT-017	17,00	17,00	1,00	-	-	-	0,089
CT-019	25,40	25,40	3,17	1	1	1/8	0,409
CT-021	31,70	31,70	1,50	1.1/4	1.1/4	1/16	0,251
CT-022	31,70	31,70	3,18	1.1/4	1.1/4	1/8	0,518
CT-025	43,00	43,00	3,30	-	-	-	0,742
CT-026	61,00	61,00	3,30	-	-	-	1,065
CT-028	38,10	38,10	1,58	1.1/2	1.1/2	1/16	0,320
CT-029	38,10	38,10	3,17	1.1/2	1.1/2	1/8	0,627
CT-050	50,80	50,80	4,76	2	2	3/16	1,127
CT-051	50,80	50,80	3,17	2	2	1/8	0,850
CT-052	50,80	50,80	1,58	2	2	1/16	0,429
CT-063	63,50	63,50	3,17	2.1/2	2.1/2		1,064
CT-209	32,00	16,20	1,20	-	-	-	0,153
L-009	19,05	19,05	1,59	3/4	3/4	1/16	0,156
L-011	19,05	19,05	3,20	3/4	3/4	1/8	0,302
L-018	38,10	38,10	3,20	1.1/2	1.1/2	1/8	0,633
L-023	38,10	38,10	4,76	1.1/2	1.1/2	3/16	0,921
PVT-021	55,00	25,40	4,76	-	1	3/16	0,975

BARRAS CHATAS

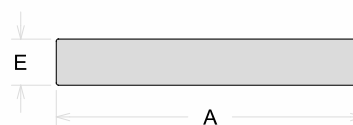

CÓDIGO	MILIMETROS		POLEGADAS		PESO (Kg/m)
	A	E	A	E	
AP-604	60,00	40,00	-	-	6,829
BAR-014	19,00	3,20	3/4	1/8	0,164
BAR-015	22,20	3,20	7/8	1/8	0,192
BAR-017	44,60	9,54	-	3/8	1,152
BAR-019	31,75	3,17	1.1/4	1/8	0,272
BAR-020	57,15	6,35	2.1/4	1/4	0,983
BAR-023	100,00	42,00	-	-	11,382
BAR-047	12,70	4,70	1/2	3/16	0,161
BAR-051	9,35	3,60	3/8	-	0,092
BAR-053	9,35	3,10	3/8	1/8	0,079
BAR-089	19,05	6,40	3/4	1/4	0,326
BAR-091	25,40	6,30	1	1/4	0,433
BAR-5028	25,00	3,00	-	-	0,203
BC-002	12,70	3,18	1/2	1/8	0,110
BC-003	12,80	2,00	1/2	-	0,069
BC-008	15,87	3,17	5/8	1/8	0,136
BC-009	15,90	4,80	5/8	3/16	0,204
BC-010	38,10	5,56	1.1/2	7/32	0,574
BC-011	31,75	4,76	1.1/4	3/16	0,409
BC-012	15,87	4,76	FRISADA (CALHA)		0,197
BC-016	19,05	4,76	3/4	3/16	0,251
BC-022	22,20	3,18	7/8	1/8	0,191
BC-024	25,40	9,53	1	3/8	0,658
BC-025	25,40	3,18	1	1/8	0,218
BC-026	25,40	12,70	1	1/2	0,874
BC-027	38,10	9,50	1.1/2	3/8	0,982
BC-028	25,40	4,80	-	-	0,328
BC-031	31,75	6,35	1.1/4	1/4	0,548
BC-043	43,00	2,90	-	-	0,338
BC-045	45,00	4,00	-	-	0,489
BC-046	50,80	9,52	2	3/8	1,316
BC-050	38,10	3,17	1.1/2	1/8	0,328
BC-051	50,80	15,87	2	5/8	2,192
BC-052	50,80	12,70	2	1/2	1,755
BC-056	56,00	2,00	-	-	0,304
BC-060	50,80	3,17	2	1/8	0,436
BC-061	50,80	4,76	2	3/16	0,657
BC-062	50,80	2,20	2	-	0,303
BC-063	63,50	3,17	2.1/2	1/8	0,545
BC-069	31,75	9,52	1.1/4	3/8	0,821

BARRAS CHATAS

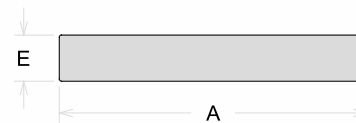

CÓDIGO	MILIMETROS		POLEGADAS		PESO (Kg/m)
	A	E	A	E	
BC-074	74,00	4,00	-	-	0,804
BC-075	76,20	6,35	3	1/4	1,316
BC-076	76,20	10,00	3	-	2,072
BC-085	85,00	3,17	-	1/8	0,733
BC-101	101,60	4,76	4	3/16	1,316
BC-110	100,00	10,00	-	-	2,710
BC-111	100,00	4,30	-	-	1,165
BC-507	76,20	3,17	3	1/8	0,657
BC-509	31,75	3,17	1.1/4	1/8	0,272
BC-525	50,00	25,00	-	-	3,387
PVQ-015	31,80	19,50	1.1/4	-	1,680

BARRAS CHATAS CANTOS ARREDONDADOS

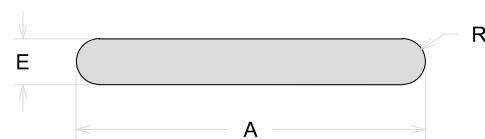

CÓDIGO	MILIMETROS			POLEGADAS		PESO (Kg/m)
	A	E	R	A	E	
BAR-5009	10,00	6,00	3,00	-	-	0,141
BAR-5018	15,87	3,90	1,95	5/8	5/32	0,160
BC-019	19,05	4,76	2,40	3/4	3/16	0,304
BC-020	19,05	4,00	-	CHANFRO 0,5X45º		0,206
BC-038	38,10	6,00	3,00	1.1/2	-	0,600
BC-039	38,10	8,00	4,00	1.1/2	-	0,791
BC-058	16,00	4,00	2,00	-	-	0,166
BC-059	15,87	4,76	2,00	5/8	3/16	0,166

VERGALHÕES QUADRADOS



CÓDIGO	MILIMETROS		POLEGADAS		PESO (Kg/m)
	A	E	A	E	
CÓDIGO	MILIMETROS		POLEGADAS		PESO (Kg/m)
	A		A		
PVQ-001	12,70		1/2		0,437
PVQ-002	19,05		3/4		0,987
PVQ-003	25,40		1		1,754
PVQ-004	35,00		1,3/8		3,332
PVQ-058	6,35		1/4		0,100

VERGALHÕES REDONDOS

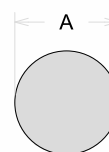

CÓDIGO	MILIMETROS		POLEGADAS		PESO (Kg/m)
	A	E	A	E	
CÓDIGO	MILIMETROS		POLEGADAS		PESO (Kg/m)
	A		A		
PVR-004	20,00		-		0,851
PVR-005	31,75		1.1/4		2,145
PVR-006	50,80		2		5,492
PVR-007	7,94		5/16		0,134
PVR-008	9,52		3/8		0,192
PVR-009	12,50		1/2		0,332
PVR-010	19,05		3/4		0,772
PVR-011	25,40		1		1,373
PVR-012	5,80		-		0,071
PVR-013	6,35		1/4		0,086
PVR-014	5,70		-		0,069
VER-004	8,3		-		0,140
VER-010	12,00		-		0,305
VER-011	12,70		1/2		0,343
VER-018	22,22		7/8		1,051
VER-027	32,05		-		2,184
VER-032	38,10		1.1/2		3,089
VER-082	5,19		-		0,057
VER-116	6,90		-		0,101
VER-122	15,87		5/8		0,536

TUBOS REDONDOS

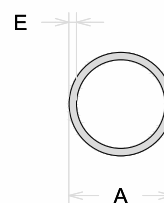

CÓDIGO	MILIMETROS		POLEGADAS		PESO (Kg/m)
	A	E	A	E	
AP-530	54,20	8,10	-	-	3,179
BK-844	20,70	1,80	13/16	-	0,289
BK-845	31,75	2,00	1.1/4	-	0,506
BK-846	20,00	1,50	-	1/16	0,236
TR-003	12,70	3,35	1/2	-	0,266
TR-004	15,87	1,20	5/8	-	0,149
TR-005	12,70	1,59	1/2	1/16	0,150
TR-012	15,87	1,00	5/8	-	0,126
TR-018	19,05	0,80	3/4	1/32	0,123
TR-022	22,20	1,00	7/8	-	0,181
TR-025	25,40	1,00	1	-	0,208
TR-026	25,40	2,00	1	-	0,398
TR-028	28,60	1,10	1.1/8	-	
TR-030	31,65	1,80	1.1/4	-	0,459
TR-031	31,65	1,25	1.1/4	-	0,324
TR-040	25,40	1,20	1	-	0,247
TR-041	25,40	1,80	1	-	0,362
TR-048	50,80	1,00	2	-	0,423
TR-060	9,55	1,55	3/8	1/16	0,104
TR-060L	9,55	1,05	3/8	-	0,075
TR-070	38,10	1,30	1.1/2	-	0,407
TR-071	38,10	3,17	1.1/2	1/8	0,948
TR-072	38,10	2,20	1.1/2	-	0,672
TR-073	38,10	1,80	1.1/2	-	0,558
TR-097	50,80	1,80	2	-	0,754
TR-098	50,80	1,59	2	1/16	0,666
TR-099	50,80	3,17	2	1/8	1,285
TR-135	76,20	1,59	3	1/16	1,004
TR-136	76,20	2,00	3	-	1,268
TR-603	60,30	3,17	2.3/8	1/8	1,540
TUB-001	9,53	1,20	3/8	-	0,085
TUB-008	12,70	1,00	1/2	-	0,100
TUB-009	12,70	1,20	1/2	-	0,120
TUB-014	14,00	1,30	-	-	0,140
TUB-019	15,88	1,58	5/8	1/16	0,191
TUB-026	19,05	1,00	3/4	-	0,154
TUB-028	19,00	1,60	3/4	1/16	0,236
TUB-030	19,05	3,17	3/4	1/8	0,430
TUB-037	22,22	1,24	7/8	-	0,221

TUBOS REDONDOS

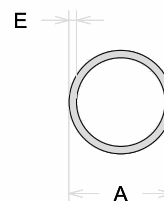

CÓDIGO	MILIMETROS		POLEGADAS		PESO (Kg/m)
	A	E	A	E	
TUB-041	22,22	3,17	7/8	1/8	0,518
TUB-045	25,40	1,30	1	-	0,268
TUB-046	25,40	1,60	1	1/16	0,323
TUB-048	25,40	3,17	1	1/8	0,600
TUB-051	28,70	1,00	1.1/8	-	0,235
TUB-052	31,75	1,00	1.1/4	-	0,261
TUB-053	38,70	4,70	-	3/16	1,360
TUB-058	31,80	3,71	1.1/4	-	0,887
TUB-208	8,10	1,20	-	-	0,070
TUB-5045	25,00	1,20	-	-	0,244
TUB-5048	28,58	1,30	1.1/8	-	0,304
TUB-5058	15,87	1,30	5/8	-	0,161
TUB-5061	19,05	1,20	3/4	-	0,182
TUB-5076	25,40	3,18	1	1/8	0,602
TUB-5077	25,40	2,00	1	-	0,398
TUB-5082	63,00	2,00	-	-	1,038
TUB-5083	40,00	2,50	-	-	0,798
TUB-5084	25,40	1,50	1	1/16	0,306
TUB-5085	42,00	3,25	1.21/32	-	1,072
TUB-541	19,05	1,20	3/4	-	0,181

VERGALHÕES SEXTAVADOS

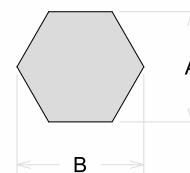

CÓDIGO	MILIMETROS		POLEGADAS		PESO (Kg/m)
	A	E	A	E	
VER-6013	25,40	29,33	1	1,5/32	1,512

TUBOS QUADRADOS

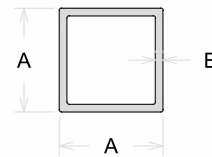

CÓDIGO	MILIMETROS		POLEGADAS		PESO (Kg/m)
	A	E	A	E	
DV-407A	12,70	0,80	1/2	1/32	0,103
TQ-009	25,40	0,85	1	1/32	0,226
TQ-010	9,60	0,80	3/8	1/32	0,076
TQ-011	25,40	1,80	1	-	0,462
TQ-012	25,40	1,50	1	1/16	0,390
TQ-013	38,10	0,80	1.1/2	1/32	0,322
TQ-014	38,10	1,80	1.1/2	-	0,711
TQ-015	38,10	1,00	CANTOS ARREDONDADOS		0,376
TQ-030	31,75	1,80	1.1/4	-	0,584
TQ-031	31,75	3,18	1.1/4	1/8	0,985
TQ-034	19,05	1,00	3/4	-	0,195
TQ-040	40,70	1,20	-	-	0,511
TQ-054	50,80	3,17	2	1/8	1,643
TQ-055	50,80	1,57	2	1/16	0,837
TQ-055L	50,80	1,30	2	-	0,697
TQ-058	50,80	2,20	2	-	1,163
TQ-060	60,00	3,50	-	-	2,141
TQ-080	80,00	1,80	-	-	1,525
TQ-100	100,00	2,00	-	-	2,125
TQ-101	101,60	2,80	4	-	3,000
TQ-102	100,00	1,50	-	1/16	1,601
TUB-4001	12,70	1,65	1/2	-	0,197
TUB-4002	15,90	1,50	5/8	1/16	0,234
TUB-4003	19,05	1,50	3/4	1/16	0,285
TUB-4011	31,75	1,50	1.1/4	1/16	0,491
TUB-4014	38,10	3,00	1.1/2	-	1,141
TUB-4020	50,80	1,70	2	-	0,904
TUB-4512	15,87	1,00	5/8	-	0,161
TUB-4805	55,00	1,20	-	-	0,700
TUB-4810	38,00	1,20	1.1/2	-	0,479
TUB-4815	9,60	1,00	3/8	-	0,093

TUBOS RETANGULARES

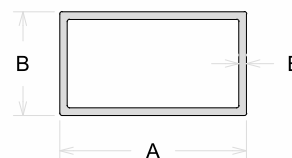

CÓDIGO	MILIMETROS			POLEGADAS			PESO (Kg/m)
	A	B	E	A	B	E	
DV-466	15,00	9,50	1,30	-	3/8	-	0,153
TG-014	14,00	7,20	1,00	-	-	-	0,104
TG-015	50,80	12,70	0,90	2	1/2	-	0,301
TG-020	76,20	38,10	1,35	3	1.1/2	-	0,816
TG-020L	76,20	38,10	1,10	3	1.1/2	-	0,668
TG-021	76,20	38,10	1,58	3	1.1/2	1/16	0,952
TG-032	30,00	20,00	1,50	-	-	-	0,382
TG-045	45,00	19,00	1,00	-	3/4	-	0,336
TG-071	50,80	25,40	1,50	2	1	1/16	0,597
TG-073	50,80	25,40	1,00	2	1	-	0,404
TG-073L	50,80	25,40	0,80	2	1	1/32	0,323
TG-074	25,40	12,70	0,80	1	1/2	1/32	0,156
TG-074L	25,40	12,70	0,70	1	1/2	-	0,139
TG-077	25,40	12,70	1,50	1	1/2	1/16	0,286
TG-095	95,00	50,80	1,60	-	2	1/16	1,238
TG-150	50,80	12,70	1,30	2	1/2	-	0,430
TG-152	152,40	38,10	2,00	6	1.1/2	-	2,206
TG-155	150,00	50,00	2,20	-	-	-	2,332
TG-156	150,00	50,00	1,50	-	-	-	1,601
TUB-4504	50,80	25,40	2,00	2	1	-	0,782
TUB-4509	30,00	20,00	2,00	-	-	-	0,498
TUB-4513	50,80	38,10	2,00	2	1.1/2	-	0,919
TUB-4536	50,80	12,70	1,58	2	1/2	1/16	0,516
TUB-4576	50,80	25,40	1,20	2	1	-	0,480
TUB-4809	27,00	8,00	1,58	-	-	1/16	0,274
TUB-5086	100,00	50,00	3,60	-	-	-	2,786
TUB-5092	24,10	9,10	1,70	-	-	-	0,274
TUB-500	101,60	50,80	1,20	-	-	-	0,978
TUB-510	101,60	50,80	1,65	4	2	-	1,333
TUB-510L	101,60	50,80	1,35	4	2	-	1,095
TUB-511	101,60	50,80	3,15	4	2	1/8	2,503
TUB-512	101,60	50,80	2,00	4	2	-	1,608
TUB-513	101,60	50,80	1,80	4	2	-	1,451

TUBOS RETANGULARES CANTOS ARREDONDADOS

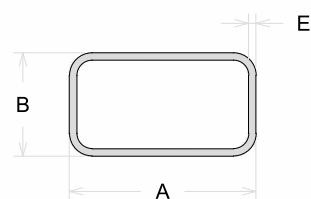

CÓDIGO	MILIMETROS			POLEGADAS			PESO (Kg/m)
	A	B	E	A	B	E	
BK-526	40,00	22,00	0,95	-	-	-	0,287
BK-527	30,00	22,00	0,95	-	-	-	0,235
BK-589	35,00	20,00	1,00	1.3/8	-	-	0,299
BK-677	63,00	17,00	1,20	-	-	-	0,490
BK-789	40,00	20,00	1,20	-	-	-	0,359
PES-002	41,00	21,00	1,00	-	-	-	0,304
PES-004	31,00	21,00	1,00	1.7/32	-	-	0,250
TG-075	50,80	25,40	1,00	2	1	-	0,378
TG-076	25,40	12,70	0,90	1	1/2	-	0,152

DV-031	Cantoneira
Peso (Kg/m)	Perfis De Encaixe:
4,774	

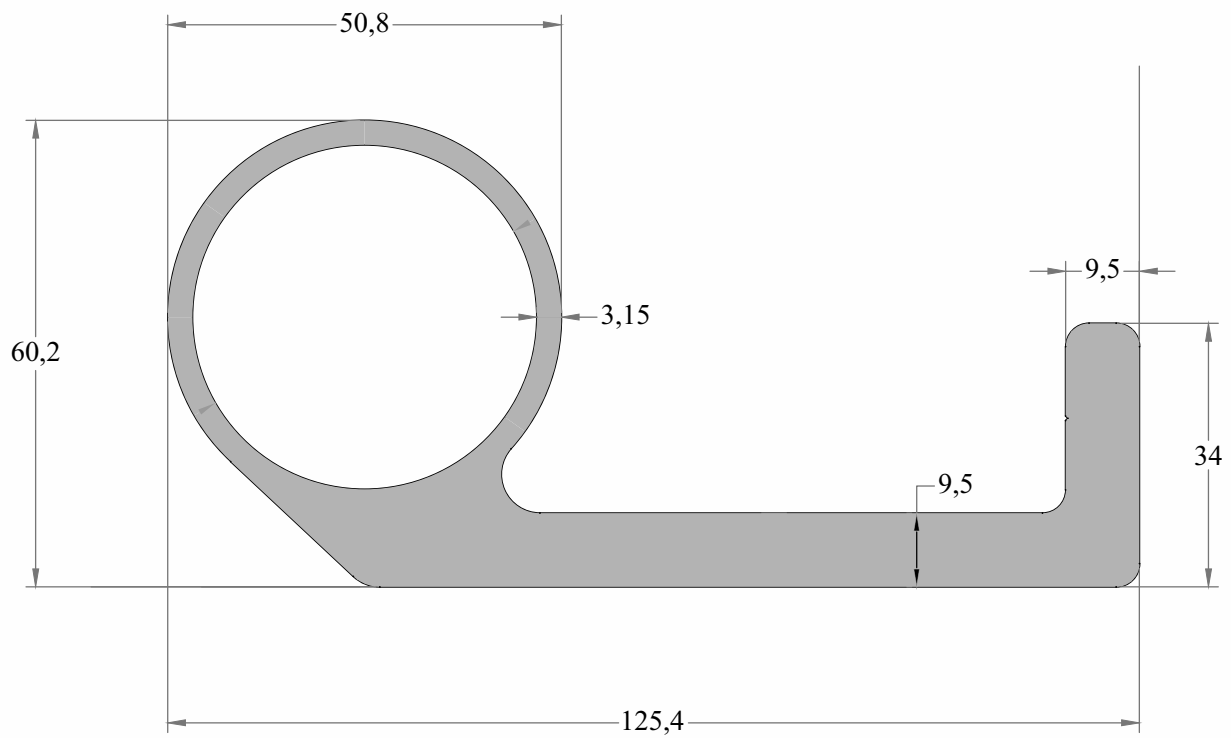

DV-033	Cantoneira
Peso (Kg/m)	Perfis De Encaixe:
2,294	



DV-034	Trava Morsa
Peso (Kg/m)	Perfis De Encaixe:
2,709	

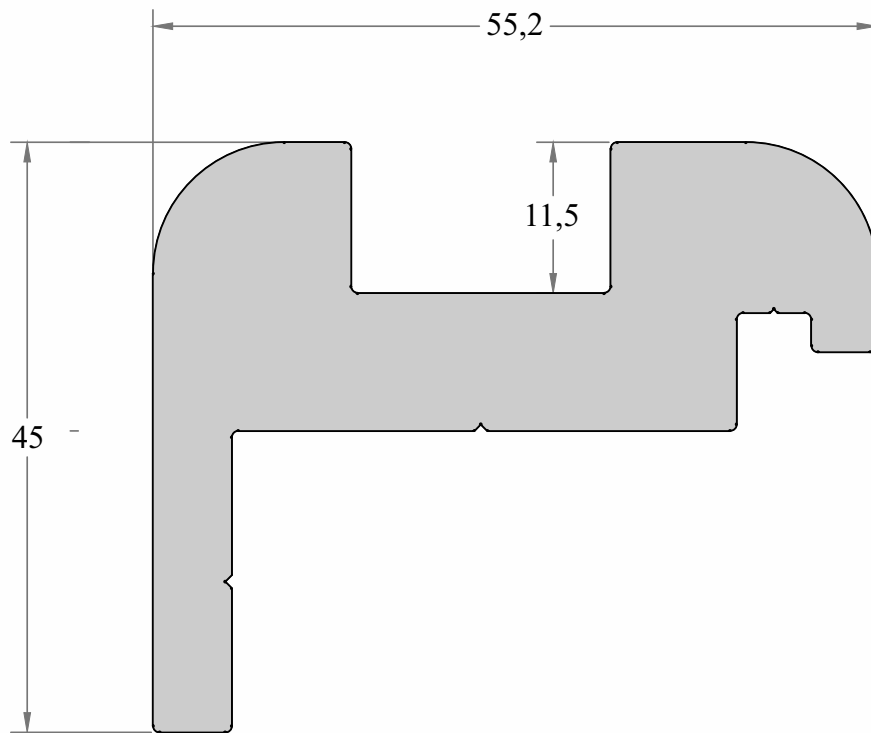

DV-035	Cantoneira
Peso (Kg/m)	Perfis De Encaixe:
5,169	

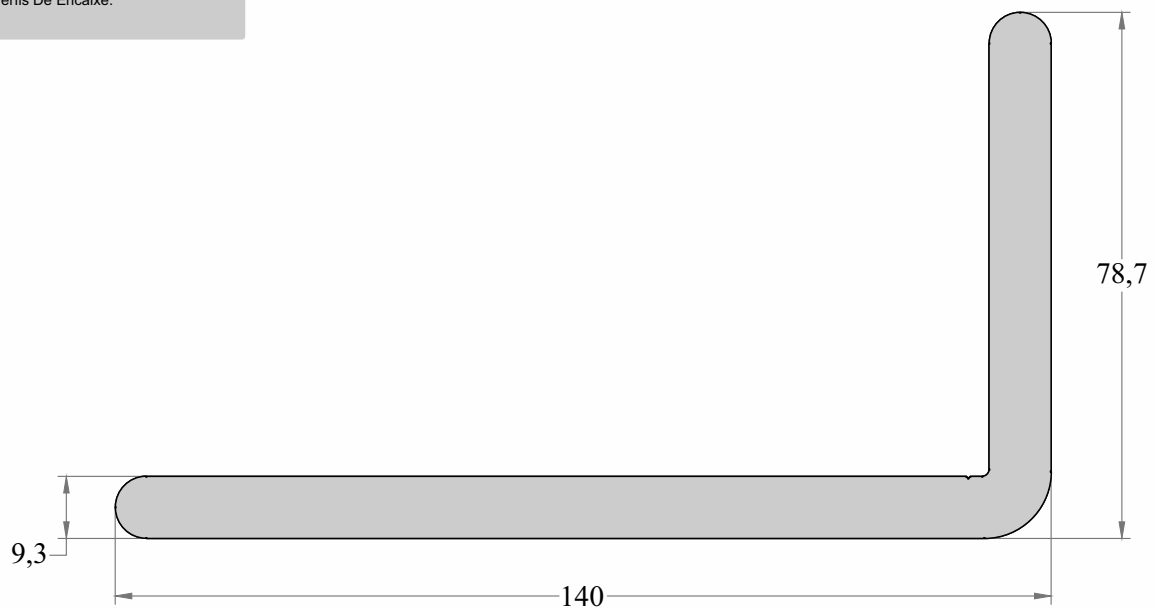

DV-036	Cantoneira Canoa
Peso (Kg/m)	Perfis De Encaixe: DV-037
4,296	

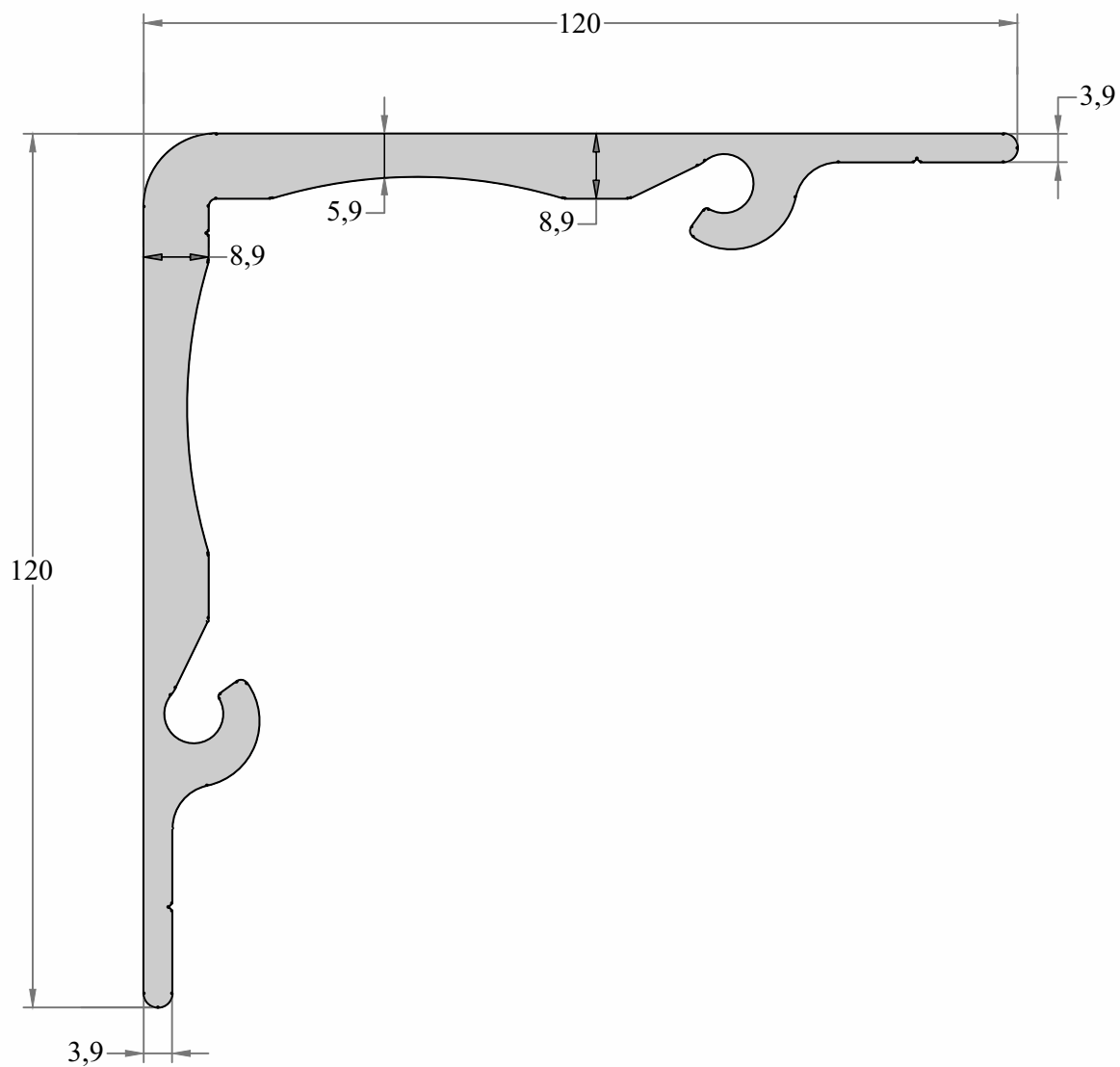

DV-037	Trava Morsa
Peso (Kg/m)	Perfis De Encaixe:
1,350	

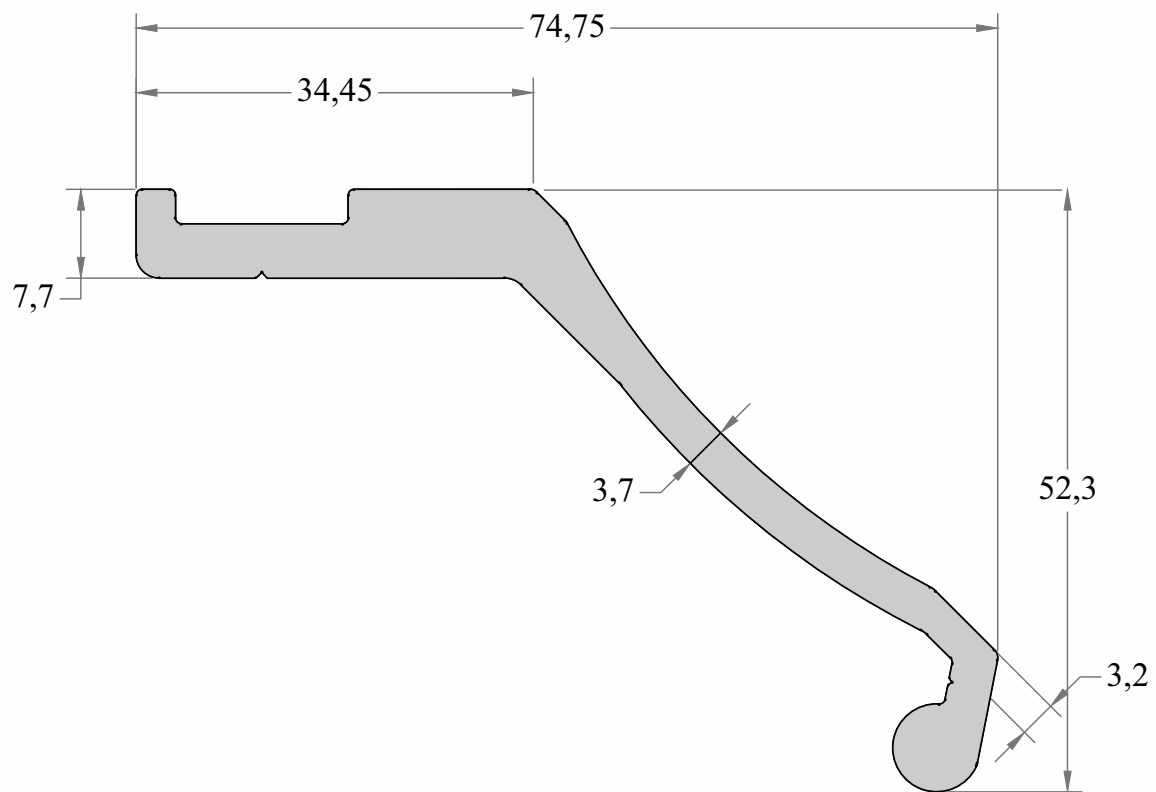

IPD-001	Modular - 52 x 52
Peso (Kg/m)	Perfis De Encaixe:
1,419	

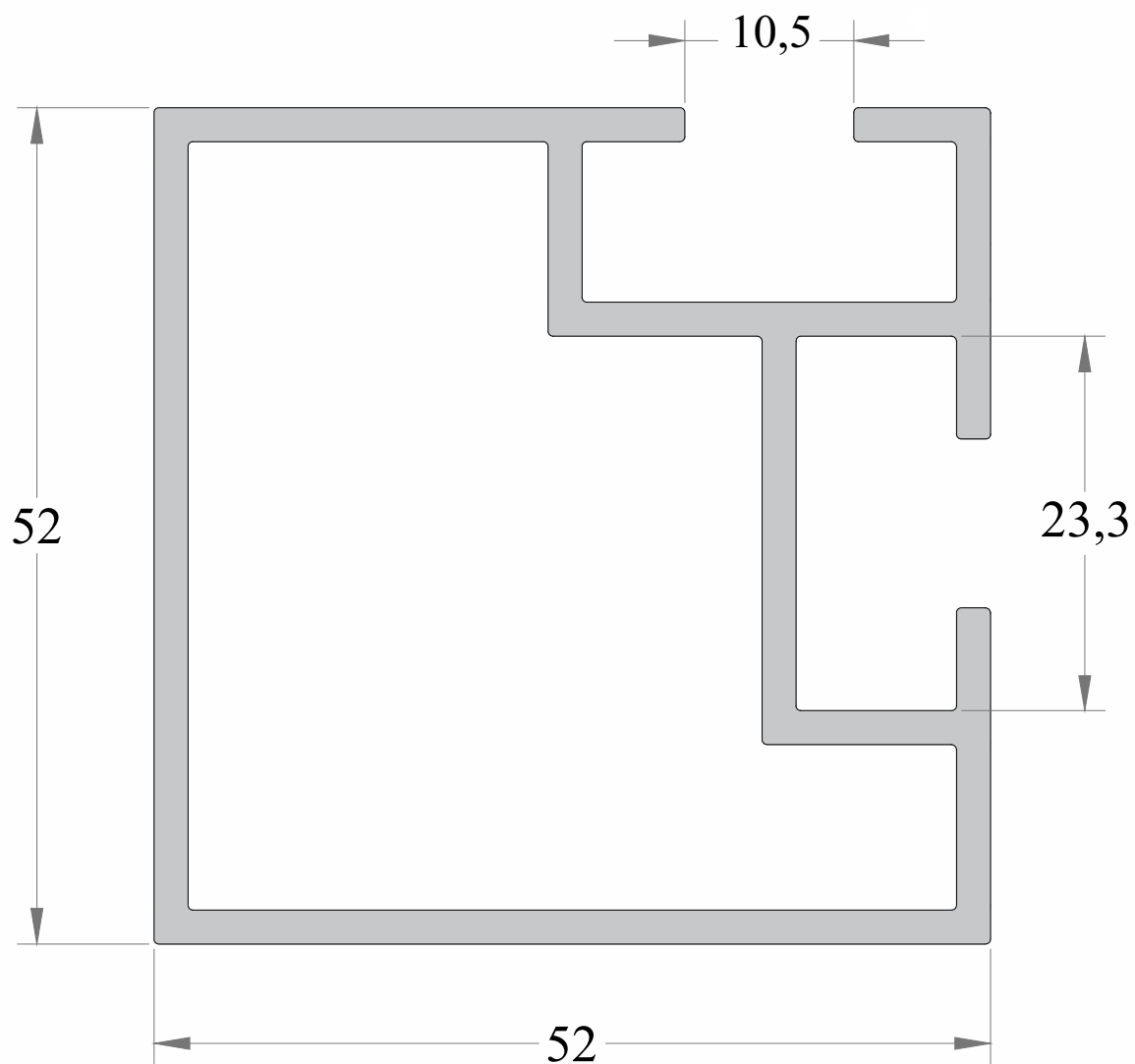

TR-099	Tubo Redondo
Peso (Kg/m)	Perfis De Encaixe:
1,285	

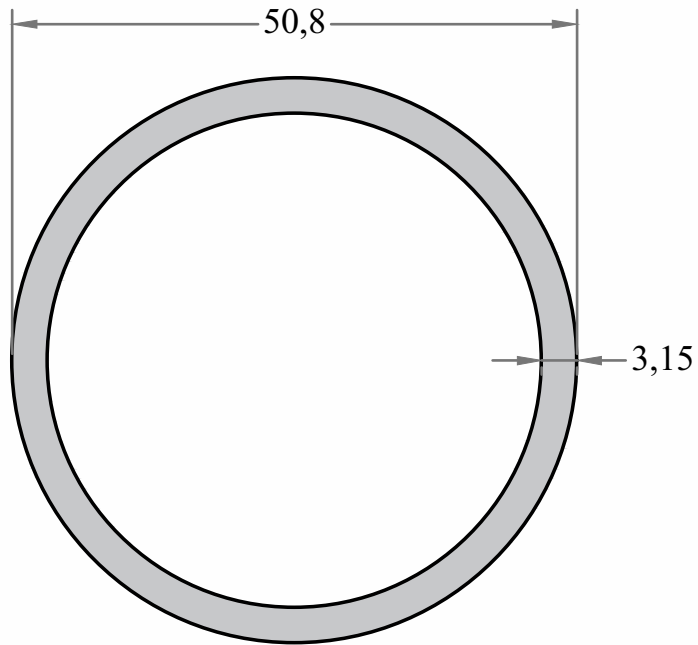

TR-098	Tubo Redondo
Peso (Kg/m)	Perfis De Encaixe:
0,666	

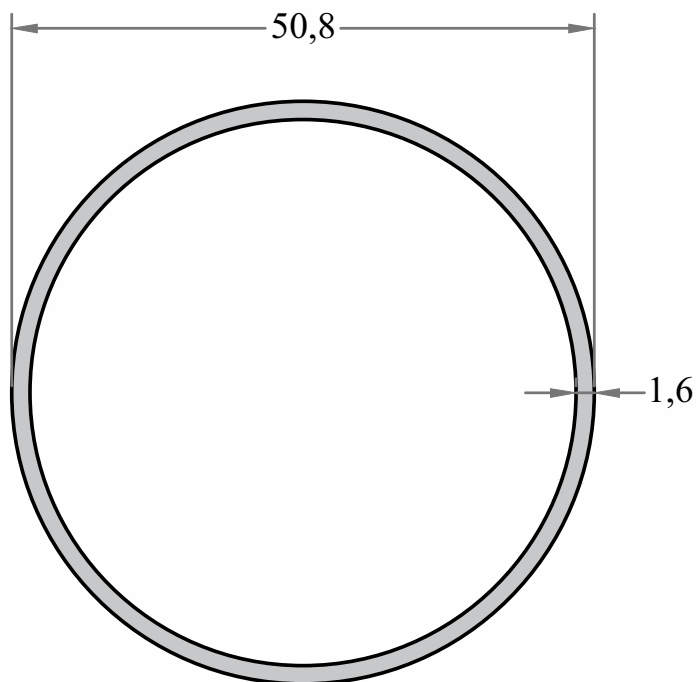

TR-072	Tubo Redondo
Peso (Kg/m)	Perfis De Encaixe:
0,672	

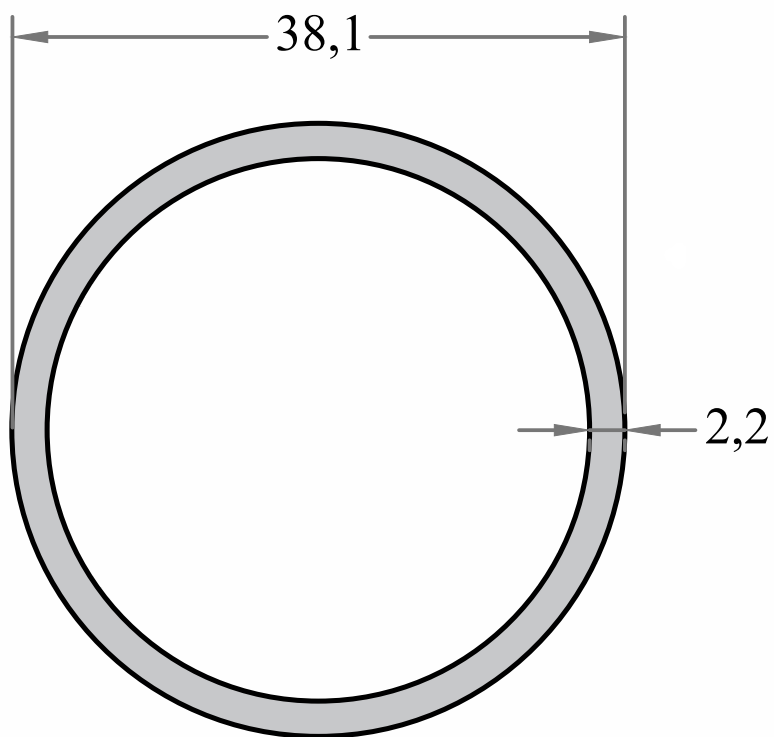

TR-071	Tubo Redondo
Peso (Kg/m)	Perfis De Encaixe:
0,948	

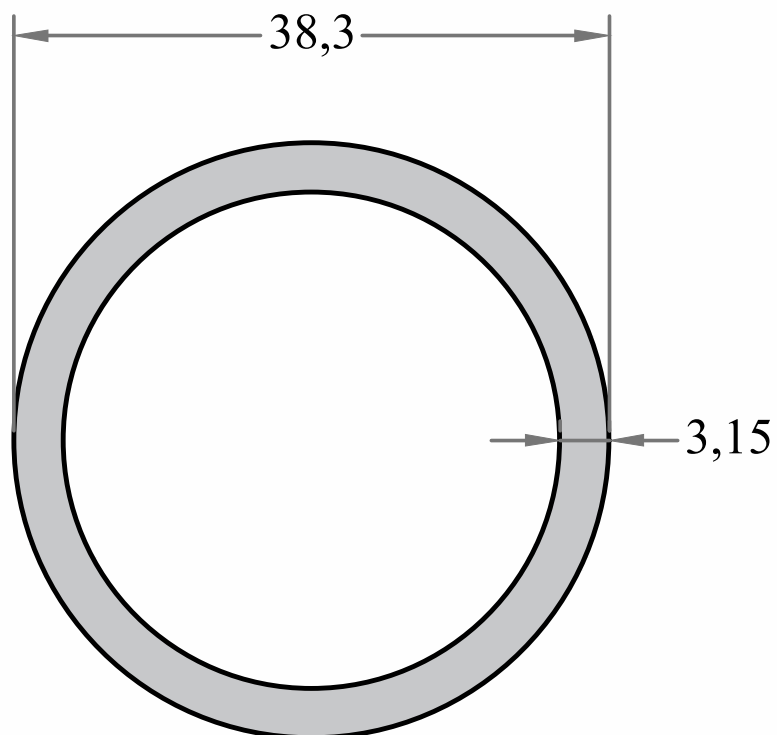

TR-070	Tubo Redondo
Peso (Kg/m)	Perfis De Encaixe:
0,407	

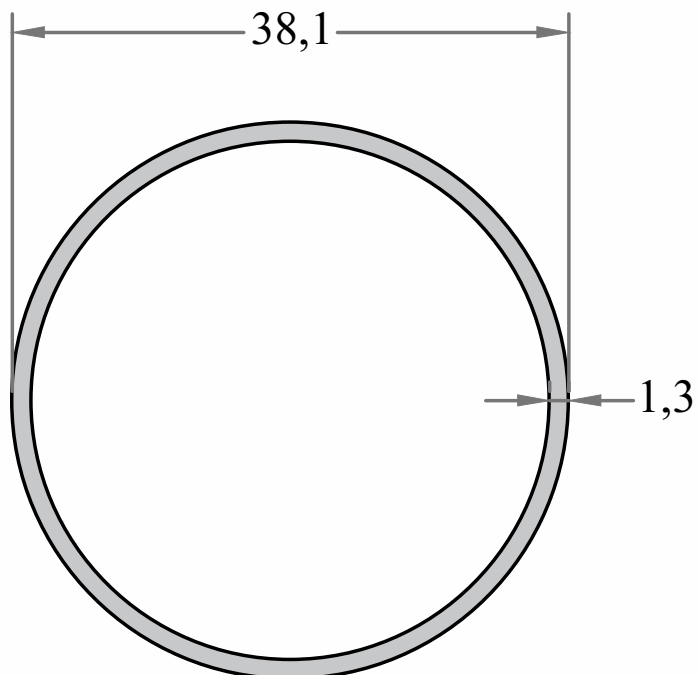

TR-040	Tubo Redondo
Peso (Kg/m)	Perfis De Encaixe:
0,247	

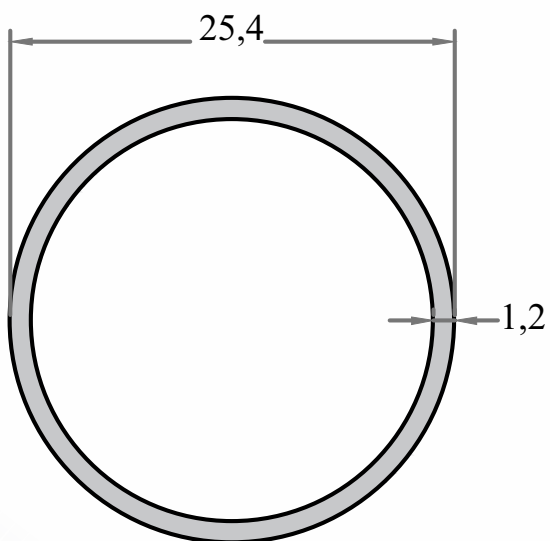

TR-026	Tubo Redondo
Peso (Kg/m)	Perfis De Encaixe:
0,398	

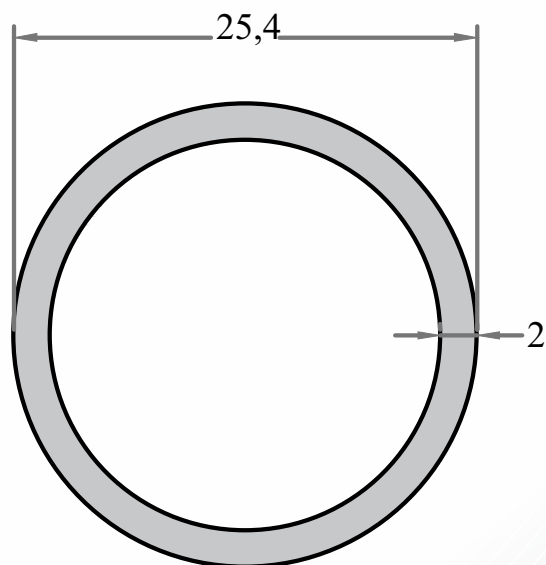

TQ-100	Tubo Quadrado
Peso (Kg/m)	Perfis De Encaixe:
2,124	

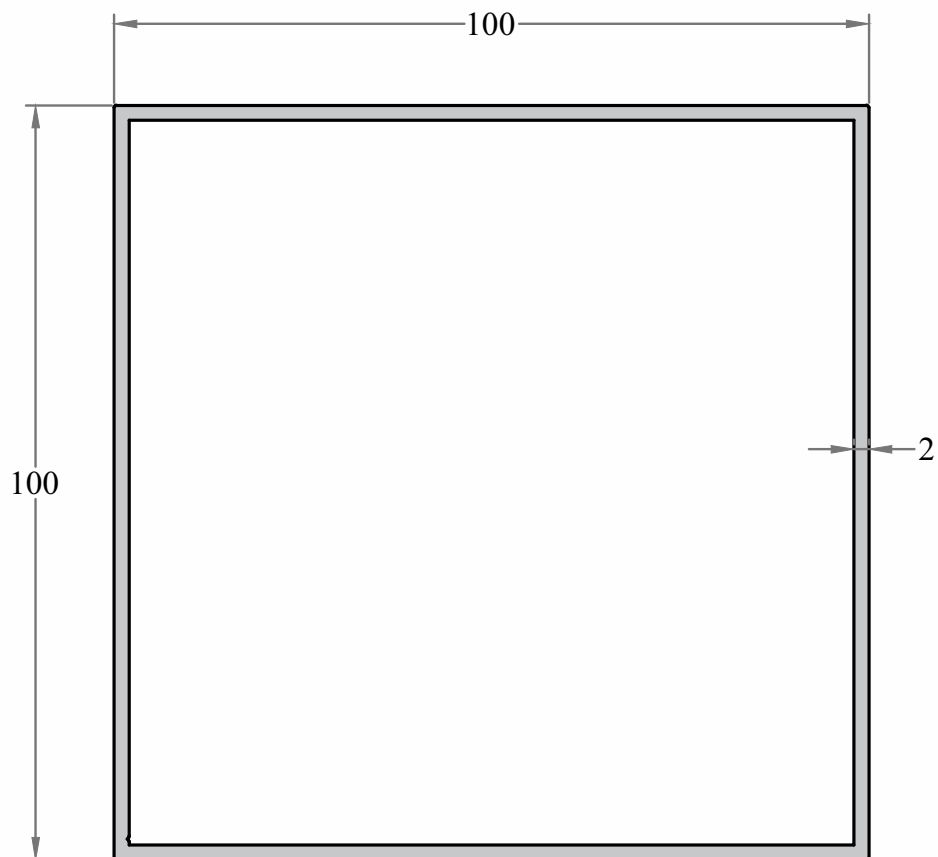

TQ-060	Tubo Quadrado
Peso (Kg/m)	Perfis De Encaixe:
2,141	

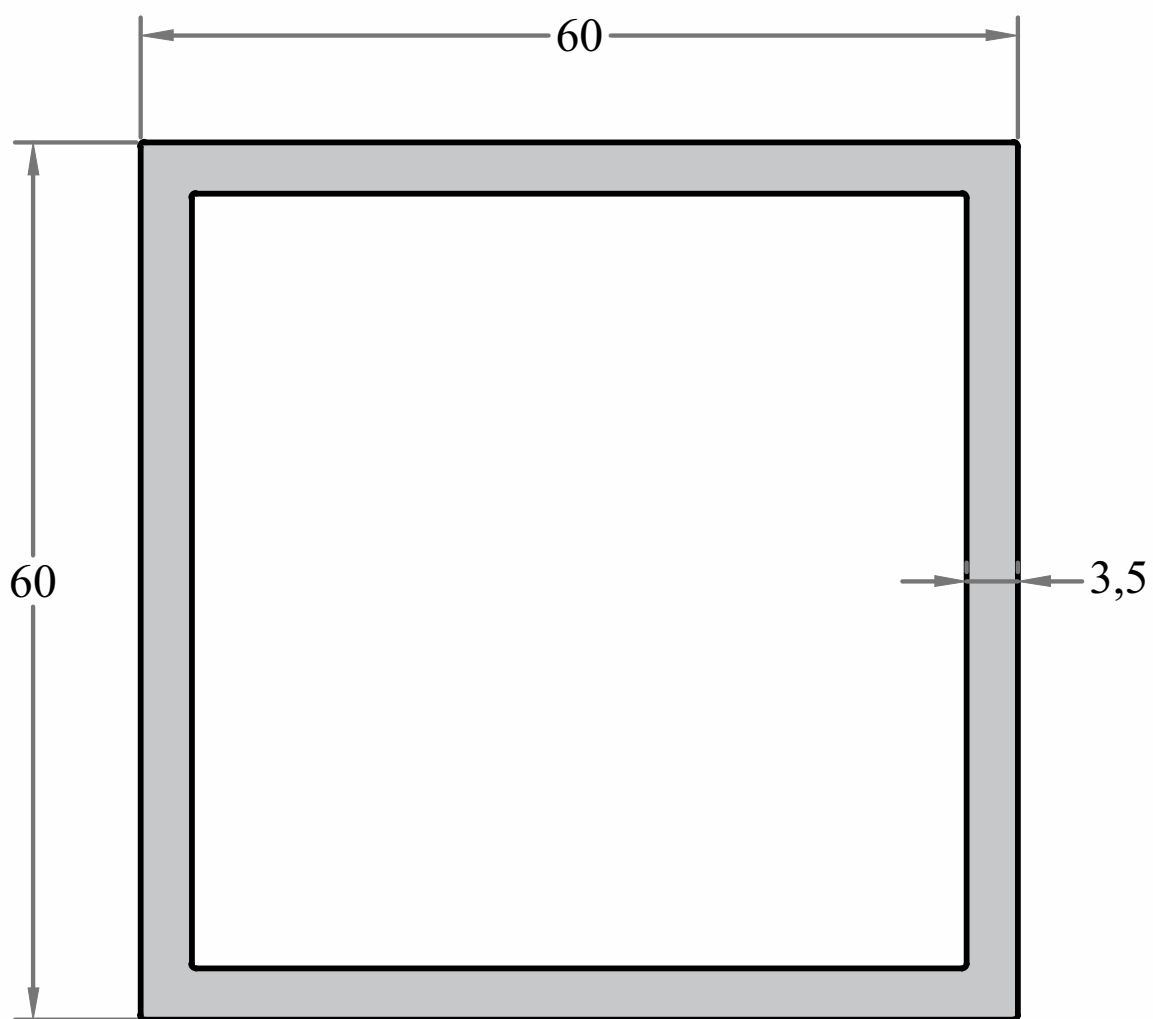

TQ-058	Tubo Quadrado
Peso (Kg/m)	Perfis De Encaixe:
1,163	

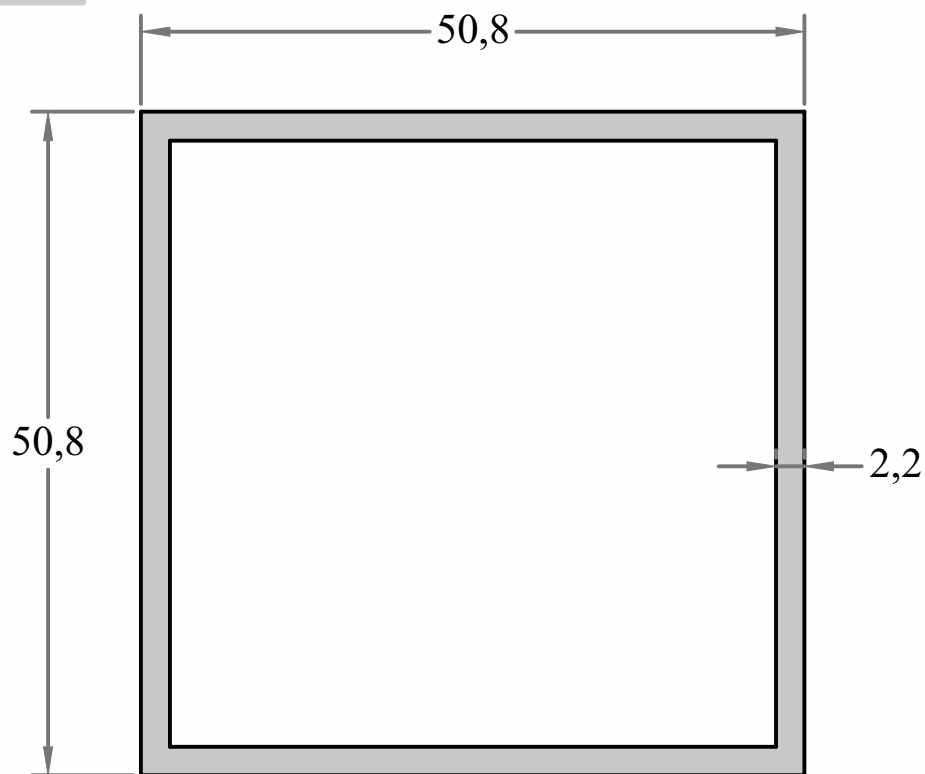

TQ-054	Tubo Quadrado
Peso (Kg/m)	Perfis De Encaixe:
1,643	

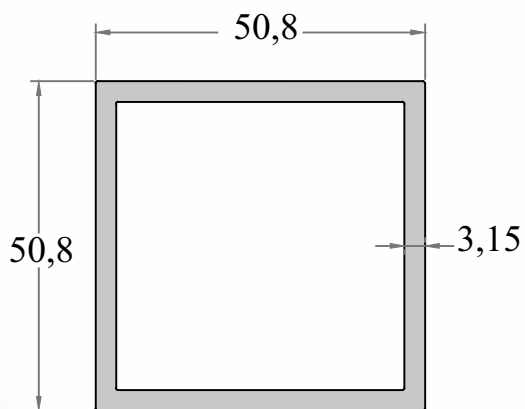

TQ-010	Tubo Quadrado
Peso (Kg/m)	Perfis De Encaixe:
0,076	

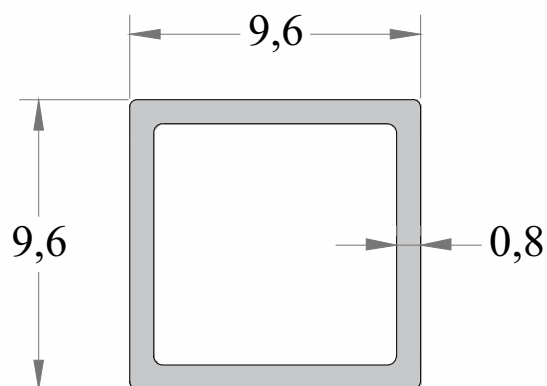

PERFISUD

EXTRUSÃO DE ALUMÍNIO

COLORSUD

TECNOLOGIA EM PINTURA

  @perfisud

Rodovia SC 370 – KM 170, S/N
Pouso Alto | Gravatal | SC
88735-000 | Brasil
+55 48 3628-0666

PERFISUD.COM.BR

