

PERFISUD.COM.BR

CONSTRUÇÃO CIVIL

Ver. 2.0

  @perfisud

PERFISUD

EXTRUSÃO DE ALUMÍNIO

POWERED BY THEO ALBORGHETTI



Localizada na cidade de Gravatal, Santa Catarina a **PERFISUD** atende a demanda de extrusão de alumínio, desde 2007, com eficiência e comprometimento.

A PERFISUD conta com 2 prensas de 5' e 1 de 7', tendo uma capacidade instalada de 1.500 ton/mês.

No ano de 2021, a PERFISUD inaugurou uma unidade de pintura eletrostática, a **COLORSUD**. Uma linha *Power Free* moderna, inovadora e altamente tecnológica. Com laboratório próprio, atendendo todas as normas para a garantia do processo e qualidade do serviço prestado. A COLORSUD tem como parceiros os melhores fornecedores, homologados **Qualicoat**.

Tudo isso para lhe entregar um produto altamente qualificado e seguro, que com certeza irá superar suas expectativas.

PERFISUD
EXTRUSÃO DE ALUMÍNIO

Missão

Atuar no mercado de alumínio com responsabilidade, qualidade e pontualidade na busca da melhor solução para todos.

Visão

Ser referência em qualidade e atendimento criando cada vez mais oportunidades de negócio até 2025.

Valores

Flexibilidade, Honestidade, Inovação e Responsabilidade.

COLORSUD
TECNOLOGIA EM PINTURA



Perfis 'U' Abas Iguais	4
Perfis 'U' Abas Desiguais	4
Cantoneiras Abas Iguais	5
Cantoneiras Abas Desiguais	5
Barras Chatas	6
Barras Chatas Cantos Arredondados	7
Vergalhões Quadrados	8
Vergalhões Redondos	8
Tubos Redondos	9
Vergalhões Sextavados	10
Tubos Quadrados	11
Tubos Retangulares	12
Tubos Retangulares Cantos Arredondados	13
Contramarcos e Conexões	14
Arremates	18
Linha 16 Basculante	22
Linha 20 Basculante	24
Linha MP - Módulo Pratico	28
Linha 25 - Portas de Giro e Maxim-Ar	36
Linha 28	49
Linha 30 - Portas de Giro e Maxim-Ar	54
Linha 42 - Portas de Giro e Pivotante	60
Linha Temperados 6mm	67
Linha Temperados 8mm	69
Linha Temperados 10mm	80
Linha Box Temperado	93
Linha Box Acrílico	98
Venezianas	103
Brises	110
Ripados	113
Lambris	119
Cercas e Portões	134
Tela Mosquiteira	143
Policarbonato	144
Envidraçamento De Sacadas	146
Corrimão / Gradil	155
Sistema Infinity Class - (Portas de Giro / Pivotante) Linhas 25 30 32 42	157
Sistema Slim View - Gradil	177
Sistema Slim 20	187
Sistema Versatic 25	195
Sistema Versatic 25 - Integrada e Maxim-Ar	224
Sistema Deluxe 32	266
Sistema Deluxe 32 - Integrada e Maxim-Ar	289
Sistema Deluxe 32 - Colatto	311
Sistema Intensive FX - Fachada Glazing	317
Sistema Stick Pratic - Fachada Glazing	336
Fachada PVII - Fachada Glazing	355
Fachada Cortina	359



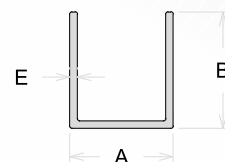

PERFIS "U" Abas Iguais

CÓDIGO	MILIMETROS			POLEGADAS			PESO (Kg/m)
	A	B	E	A	B	E	
PU-002	12,70	12,70	1,50	1/2	1/2	1/16	0,142
PU-003	9,52	9,52	1,10	3/8	3/8	-	0,142
PU-004	15,87	15,87	1,20	5/8	5/8	-	0,147
PU-006	38,00	38,00	1,50	1.1/2	1.1/2	1/16	0,450
PU-207	19,05	12,70	1,58	3/4	1/2	1/16	0,177
U-036	9,50	9,50	1,58	3/8	3/8	1/16	0,108

PERFIS "U" Abas Desiguais

CÓDIGO	MILIMETROS			POLEGADAS			PESO (Kg/m)
	A	B	E	A	B	E	
BX-064	14,00	22,00	1,20	-	-	-	0,162
CX-900	29,00	17,50	1,50	-	-	1/16	0,247
CX-901	26,00	13,00	1,50	-	-	1/16	0,198
PAL-010	15,50	25,00	1,20	-	-	-	0,196
PAL-010L	15,00	25,00	0,90	-	-	-	0,157
PAL-011	15,50	25,00	1,20	-	-	-	0,188
PAL-024	15,60	48,00	1,80	-	-	-	0,527
PAL-025	14,40	48,00	1,20	-	-	-	0,350
PAL-054	11,00	20,00	1,20	-	-	-	0,128
PAL-067	13,80	22,00	1,00	-	-	-	0,143
PAL-540	11,00	22,00	1,20	-	-	-	0,140
PU-005	11,00	15,00	1,10	-	-	-	0,115
PU-014	14,00	15,00	1,10	-	-	-	0,125
PU-015	12,70	15,87	1,59	1/2	5/8	1/16	0,177
PU-019	29,00	19,00	1,50	-	-	1/16	0,259
PU-025	50,80	25,40	3,17	2	1	1/8	0,821
PU-035	35,30	40,00	2,50	-	-	-	0,686
PU-038	9,52	12,70	1,59	3/8	1/2	1/16	0,136
PU-047	29,00	35,00	1,50	-	1.3/8	-	0,390
PU-207	19,05	12,70	1,58	3/4	1/2	1/16	0,177
U-639	29,00	35,00	1,50	-	1.3/8	1/16	0,390
U-901	18,00	15,00	1,00	-	-	-	0,125
U-902	29,00	16,00	1,00	-	-	-	0,160
U-903	25,40	12,70	3,18	1	1/2	1/8	0,382
U-904	13,30	11,00	1,00	-	-	-	0,090

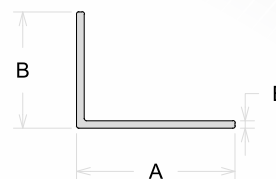
CANTONEIRAS ABAS IGUAIS

CÓDIGO	MILIMETROS			POLEGADAS			PESO (Kg/m)
	A	B	E	A	B	E	
CT-001	12,70	12,70	1,58	1/2	1/2	1/16	0,102
CT-002	15,90	15,90	3,20	5/8	5/8	1/8	0,246
CT-005	15,87	15,87	1,20	5/8	5/8	-	0,100
CT-007	19,05	19,05	1,20	3/4	3/4	-	0,120
CT-016	25,40	25,40	1,59	1	1	1/16	0,212
CT-016L	25,40	25,40	1,20	1	1	-	0,161
CT-017	17,00	17,00	1,00	-	-	-	0,089
CT-019	25,40	25,40	3,17	1	1	1/8	0,409
CT-021	31,70	31,70	1,50	1.1/4	1.1/4	1/16	0,251
CT-022	31,70	31,70	3,18	1.1/4	1.1/4	1/8	0,518
CT-025	43,00	43,00	3,30	-	-	-	0,742
CT-026	61,00	61,00	3,30	-	-	-	1,065
CT-028	38,10	38,10	1,58	1.1/2	1.1/2	1/16	0,320
CT-029	38,10	38,10	3,17	1.1/2	1.1/2	1/8	0,627
CT-050	50,80	50,80	4,76	2	2	3/16	1,127
CT-051	50,80	50,80	3,17	2	2	1/8	0,850
CT-052	50,80	50,80	1,58	2	2	1/16	0,429
CT-063	63,50	63,50	3,17	2.1/2	2.1/2	-	1,064
L-009	19,05	19,05	1,59	3/4	3/4	1/16	0,156
L-011	19,05	19,05	3,20	3/4	3/4	1/8	0,302
L-018	38,10	38,10	3,20	1.1/2	1.1/2	1/8	0,633
L-023	38,10	38,10	4,76	1.1/2	1.1/2	3/16	0,921

CANTONEIRAS ABAS DESIGUAIS

CÓDIGO	MILIMETROS			POLEGADAS			PESO (Kg/m)
	A	B	E	A	B	E	
BK-879	90,40	45,20	6,00	-	RAIO	-	2,148
BK-883	65,00	55,20	5,00	-	RAIO	-	1,589
CD-001	20,00	13,00	2,50	-	-	-	0,208
CD-002	50,00	30,00	3,00	-	-	-	0,625
CD-003	50,80	38,10	3,17	2	1.1/2	1/8	0,737
CD-004	50,00	75,00	4,50	C/ RANHURA			1,427
CD-006	50,00	25,00	1,50	-	-	1/16	0,299
CD-007	25,40	12,70	3,17	1	1/2	1/8	0,300
CD-008	50,00	43,00	4,30	-	-	-	1,037
CD-016	40,00	16,00	-	-	-	-	1,192
CD-076	76,00	25,00	-	-	-	-	2,360
CD-108	108,00	51,00	4,76	-	-	3/16	1,996
CT-209	32,00	16,20	1,20	-	-	-	0,153
PVT-021	55,00	25,40	4,76	-	1	3/16	0,975

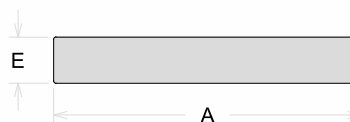
BARRAS CHATAS

CÓDIGO	MILIMETROS		POLEGADAS		PESO (Kg/m)
	A	E	A	E	
AP-604	60,00	40,00	-	-	6,829
BAR-014	19,00	3,20	3/4	1/8	0,164
BAR-015	22,20	3,20	7/8	1/8	0,192
BAR-017	44,60	9,54	-	3/8	1,152
BAR-019	31,75	3,17	1.1/4	1/8	0,272
BAR-020	57,15	6,35	2.1/4	1/4	0,983
BAR-023	100,00	42,00	-	-	11,382
BAR-047	12,70	4,70	1/2	3/16	0,161
BAR-051	9,35	3,60	3/8	-	0,092
BAR-053	9,35	3,10	3/8	1/8	0,079
BAR-089	19,05	6,40	3/4	1/4	0,326
BAR-091	25,40	6,30	1	1/4	0,433
BAR-5028	25,00	3,00	-	-	0,203
BC-002	12,70	3,18	1/2	1/8	0,110
BC-003	12,80	2,00	1/2	-	0,069
BC-008	15,87	3,17	5/8	1/8	0,136
BC-009	15,90	4,80	5/8	3/16	0,204
BC-010	38,10	5,56	1.1/2	7/32	0,574
BC-011	31,75	4,76	1.1/4	3/16	0,409
BC-012	15,87	4,76	FRISADA (CALHA)		0,197
BC-014	14,20	6,00	-	-	0,230
BC-015	30,00	4,00	-	-	0,233
BC-016	19,05	4,76	3/4	3/16	0,251
BC-022	22,20	3,18	7/8	1/8	0,191
BC-024	25,40	9,53	1	3/8	0,658
BC-025	25,40	3,18	1	1/8	0,218
BC-026	25,40	12,70	1	1/2	0,874
BC-027	38,10	9,50	1.1/2	3/8	0,982
BC-098	30,00	6,00	-	-	0,488
BC-031	31,75	6,35	1.1/4	1/4	0,548
BC-043	43,00	2,90	-	-	0,338
BC-045	45,00	4,00	-	-	0,489
BC-046	50,80	9,52	2	3/8	1,316
BC-050	38,10	3,17	1.1/2	1/8	0,328
BC-051	50,80	15,87	2	5/8	2,192
BC-052	50,80	12,70	2	1/2	1,755
BC-056	56,00	2,00	-	-	0,304
BC-060	50,80	3,17	2	1/8	0,436
BC-061	50,80	4,76	2	3/16	0,657
BC-062	50,80	2,20	2	-	0,303
BC-063	63,50	3,17	2.1/2	1/8	0,545
BC-069	31,75	9,52	1.1/4	3/8	0,821

BARRAS CHATAS

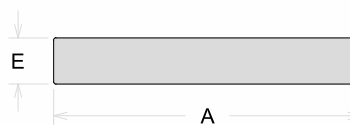

CÓDIGO	MILIMETROS		POLEGADAS		PESO (Kg/m)
	A	E	A	E	
BC-074	74,00	4,00	-	-	0,804
BC-075	76,20	6,35	3	1/4	1,316
BC-076	76,20	10,00	3	-	2,072
BC-085	85,00	3,17	-	1/8	0,733
BC-101	101,60	4,76	4	3/16	1,316
BC-110	100,00	10,00	-	-	2,710
BC-111	100,00	4,30	-	-	1,165
BC-507	76,20	3,17	3	1/8	0,657
BC-509	31,75	3,17	1.1/4	1/8	0,272
BC-525	50,00	25,00	-	-	3,387
PVQ-015	31,80	19,50	1.1/4	-	1,680

BARRAS CHATAS CANTOS ARREDONDADOS

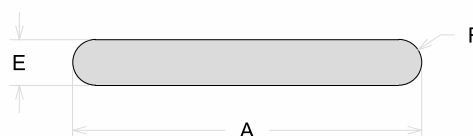

CÓDIGO	MILIMETROS			POLEGADAS		PESO (Kg/m)
	A	E	R	A	E	
BAR-5009	10,00	6,00	3,00	-	-	0,141
BAR-5018	15,87	3,90	1,95	5/8	5/32	0,160
BC-019	19,05	4,76	2,40	3/4	3/16	0,304
BC-020	19,05	4,00	-	CHANFRO 0,5X45º		0,206
BC-038	38,10	6,00	3,00	1.1/2	-	0,600
BC-039	38,10	8,00	4,00	1.1/2	-	0,791
BC-058	16,00	4,00	2,00	-	-	0,166
BC-059	15,87	4,76	2,00	5/8	3/16	0,166

VERGALHÕES QUADRADOS

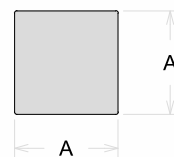

CÓDIGO	MILIMETROS		POLEGADAS		PESO (Kg/m)
	A	E	A	E	
CÓDIGO	MILIMETROS		POLEGADAS		PESO (Kg/m)
	A		A		
PVQ-001	12,70		1/2		0,437
PVQ-002	19,05		3/4		0,987
PVQ-003	25,40		1		1,754
PVQ-004	35,00		1,3/8		3,332
PVQ-058	6,35		1/4		0,100

VERGALHÕES REDONDOS

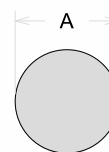

CÓDIGO	MILIMETROS		POLEGADAS		PESO (Kg/m)
	A	E	A	E	
CÓDIGO	MILIMETROS		POLEGADAS		PESO (Kg/m)
	A		A		
PVR-004	20,00		-		0,851
PVR-005	31,75		1.1/4		2,145
PVR-006	50,80		2		5,492
PVR-007	7,94		5/16		0,134
PVR-008	9,52		3/8		0,192
PVR-009	12,50		1/2		0,332
PVR-010	19,05		3/4		0,772
PVR-011	25,40		1		1,373
PVR-012	5,80		-		0,071
PVR-013	6,35		1/4		0,086
PVR-014	5,70		-		0,069
VER-004	8,3		-		0,140
VER-010	12,00		-		0,305
VER-011	12,70		1/2		0,343
VER-018	22,22		7/8		1,051
VER-027	32,05		-		2,184
VER-032	38,10		1.1/2		3,089
VER-082	5,19		-		0,057
VER-116	6,90		-		0,101
VER-122	15,87		5/8		0,536

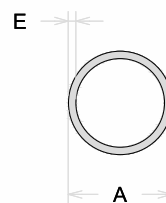
**TUBOS
REDONDOS**

CÓDIGO	MILIMETROS		POLEGADAS		PESO (Kg/m)
	A	E	A	E	
AP-530	54,20	8,10	-	-	3,179
BK-844	20,70	1,80	13/16	-	0,289
BK-845	31,75	2,00	1.1/4	-	0,506
BK-846	20,00	1,50	-	1/16	0,236
TR-003	12,70	3,35	1/2	-	0,266
TR-004	15,87	1,20	5/8	-	0,149
TR-005	12,70	1,59	1/2	1/16	0,150
TR-012	15,87	1,00	5/8	-	0,126
TR-018	19,05	0,80	3/4	1/32	0,123
TR-022	22,20	1,00	7/8	-	0,181
TR-025	25,40	1,00	1	-	0,208
TR-026	25,40	2,00	1	-	0,398
TR-028	28,60	1,10	1.1/8	-	0,258
TR-030	31,65	1,80	1.1/4	-	0,459
TR-031	31,65	1,25	1.1/4	-	0,324
TR-040	25,40	1,20	1	-	0,247
TR-041	25,40	1,80	1	-	0,362
TR-048	50,80	1,00	2	-	0,423
TR-060	9,55	1,55	3/8	1/16	0,104
TR-060L	9,55	1,05	3/8	-	0,075
TR-070	38,10	1,30	1.1/2	-	0,407
TR-071	38,10	3,17	1.1/2	1/8	0,948
TR-072	38,10	2,20	1.1/2	-	0,672
TR-073	38,10	1,80	1.1/2	-	0,558
TR-097	50,80	1,80	2	-	0,754
TR-098	50,80	1,59	2	1/16	0,666
TR-099	50,80	3,17	2	1/8	1,285
TR-135	76,20	1,59	3	1/16	1,004
TR-136	76,20	2,00	3	-	1,268
TR-603	60,30	3,17	2.3/8	1/8	1,540
TUB-001	9,53	1,20	3/8	-	0,085
TUB-008	12,70	1,00	1/2	-	0,100
TUB-009	12,70	1,20	1/2	-	0,120
TUB-014	14,00	1,30	-	-	0,140
TUB-019	15,88	1,58	5/8	1/16	0,191
TUB-026	19,05	1,00	3/4	-	0,154
TUB-028	19,00	1,60	3/4	1/16	0,236
TUB-030	19,05	3,17	3/4	1/8	0,430
TUB-037	22,22	1,24	7/8	-	0,221

TUBOS REDONDOS

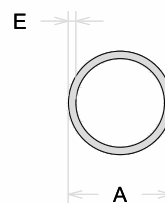

CÓDIGO	MILIMETROS		POLEGADAS		PESO (Kg/m)
	A	E	A	E	
TUB-041	22,22	3,17	7/8	1/8	0,518
TUB-045	25,40	1,30	1	-	0,268
TUB-046	25,40	1,60	1	1/16	0,323
TUB-048	25,40	3,17	1	1/8	0,600
TUB-051	28,70	1,00	1.1/8	-	0,235
TUB-052	31,75	1,00	1.1/4	-	0,261
TUB-053	38,70	4,70	-	3/16	1,360
TUB-058	31,80	3,71	1.1/4	-	0,887
TUB-208	8,10	1,20	-	-	0,070
TUB-5045	25,00	1,20	-	-	0,244
TUB-5048	28,58	1,30	1.1/8	-	0,304
TUB-5058	15,87	1,30	5/8	-	0,161
TUB-5061	19,05	1,20	3/4	-	0,182
TUB-5076	25,40	3,18	1	1/8	0,602
TUB-5077	25,40	2,00	1	-	0,398
TUB-5082	63,00	2,00	-	-	1,038
TUB-5083	40,00	2,50	-	-	0,798
TUB-5084	25,40	1,50	1	1/16	0,306
TUB-5085	42,00	3,25	1.21/32	-	1,072
TUB-541	19,05	1,20	3/4	-	0,181

VERGALHÕES SEXTAVADOS

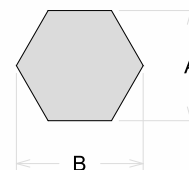

CÓDIGO	MILIMETROS		POLEGADAS		PESO (Kg/m)
	A	E	A	E	
VER-6013	25,40	29,33	1	1,5/32	1,512

TUBOS QUADRADOS

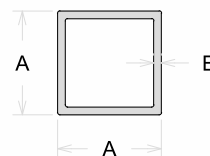

CÓDIGO	MILIMETROS		POLEGADAS		PESO (Kg/m)
	A	E	A	E	
DV-407A	12,70	0,80	1/2	1/32	0,103
TQ-009	25,40	0,85	1	1/32	0,226
TQ-010	9,60	0,80	3/8	1/32	0,076
TQ-011	25,40	1,80	1	-	0,462
TQ-012	25,40	1,50	1	1/16	0,390
TQ-013	38,10	0,80	1.1/2	1/32	0,322
TQ-014	38,10	1,80	1.1/2	-	0,711
TQ-015	38,10	1,00	CANTOS ARREDONDADOS		0,376
TQ-030	31,75	1,80	1.1/4	-	0,584
TQ-031	31,75	3,18	1.1/4	1/8	0,985
TQ-034	19,05	1,00	3/4	-	0,195
TQ-040	40,70	1,20	-	-	0,511
TQ-054	50,80	3,17	2	1/8	1,643
TQ-055	50,80	1,57	2	1/16	0,837
TQ-055L	50,80	1,30	2	-	0,697
TQ-058	50,80	2,20	2	-	1,163
TQ-060	60,00	3,50	-	-	2,141
TQ-080	80,00	1,80	-	-	1,525
TQ-100	100,00	2,00	-	-	2,125
TQ-101	101,60	2,80	4	-	3,000
TQ-102	100,00	1,50	-	1/16	1,601
TUB-4001	12,70	1,65	1/2	-	0,197
TUB-4002	15,90	1,50	5/8	1/16	0,234
TUB-4003	19,05	1,50	3/4	1/16	0,285
TUB-4011	31,75	1,50	1.1/4	1/16	0,491
TUB-4014	38,10	3,00	1.1/2	-	1,141
TUB-4020	50,80	1,70	2	-	0,904
TUB-4512	15,87	1,00	5/8	-	0,161
TUB-4805	55,00	1,20	-	-	0,700
TUB-4810	38,00	1,20	1.1/2	-	0,479
TUB-4815	9,60	1,00	3/8	-	0,093

TUBOS RETANGULARES



CÓDIGO	MILIMETROS			POLEGADAS			PESO (Kg/m)
	A	B	E	A	B	E	
DV-466	15,00	9,50	1,30	-	3/8	-	0,153
TG-014	14,00	7,20	1,00	-	-	-	0,104
TG-015	50,80	12,70	0,90	2	1/2	-	0,301
TG-020	76,20	38,10	1,35	3	1.1/2	-	0,816
TG-020L	76,20	38,10	1,10	3	1.1/2	-	0,668
TG-021	76,20	38,10	1,58	3	1.1/2	1/16	0,952
TG-025	50,00	20,00		-	-	-	0,368
TG-032	30,00	20,00	1,50	-	-	-	0,382
TG-045	45,00	19,00	1,00	-	3/4	-	0,336
TG-050	50,80	38,10		-	-	-	0,470
TG-071	50,80	25,40	1,50	2	1	1/16	0,597
TG-073	50,80	25,40	1,00	2	1	-	0,404
TG-073L	50,80	25,40	0,80	2	1	1/32	0,323
TG-074	25,40	12,70	0,80	1	1/2	1/32	0,156
TG-074L	25,40	12,70	0,70	1	1/2	-	0,139
TG-077	25,40	12,70	1,50	1	1/2	1/16	0,286
TG-095	95,00	50,80	1,60	-	2	1/16	1,238
TG-150	50,80	12,70	1,30	2	1/2	-	0,430
TG-152	152,40	38,10	2,00	6	1.1/2	-	2,206
TG-155	150,00	50,00	2,20	-	-	-	2,332
TG-156	150,00	50,00	1,50	-	-	-	1,601
TG-175	150,00	75,00	1,80	-	-	-	2,159
TG-200	150,00	100,00	2,00	-	-	-	2,666
TUB-4504	50,80	25,40	2,00	2	1	-	0,782
TUB-4509	30,00	20,00	2,00	-	-	-	0,498
TUB-4513	50,80	38,10	2,00	2	1.1/2	-	0,919
TUB-4536	50,80	12,70	1,58	2	1/2	1/16	0,516
TUB-4576	50,80	25,40	1,20	2	1	-	0,480
TUB-4809	27,00	8,00	1,58	-	-	1/16	0,274
TUB-5086	100,00	50,00	3,60	-	-	-	2,786
TUB-5092	24,10	9,10	1,70	-	-	-	0,274
TUB-500	101,60	50,80	1,20	-	-	-	0,978
TUB-510	101,60	50,80	1,65	4	2	-	1,333
TUB-510L	101,60	50,80	1,35	4	2	-	1,095
TUB-511	101,60	50,80	3,15	4	2	1/8	2,503
TUB-512	101,60	50,80	2,00	4	2	-	1,608
TUB-513	101,60	50,80	1,80	4	2	-	1,451

**TUBOS
RETANGULARES
CANTOS ARREDONDADOS**

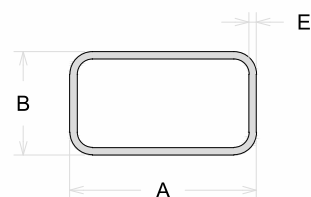

CÓDIGO	MILIMETROS			POLEGADAS			PESO (Kg/m)
	A	B	E	A	B	E	
BK-526	40,00	22,00	0,95	-	-	-	0,287
BK-527	30,00	22,00	0,95	-	-	-	0,235
BK-589	35,00	20,00	1,00	1.3/8	-	-	0,299
BK-677	63,00	17,00	1,20	-	-	-	0,490
BK-789	40,00	20,00	1,20	-	-	-	0,359
PES-002	41,00	21,00	1,00	-	-	-	0,304
PES-004	31,00	21,00	1,00	1.7/32	-	-	0,250
TG-075	50,80	25,40	1,00	2	1	-	0,378
TG-076	25,40	12,70	0,90	1	1/2	-	0,152

CL-007	Cantoneira 45°
Peso (Kg/m)	Perfis De Encaixe: Linha 20 Basculante / Módulo Maxim Ar
0,957	

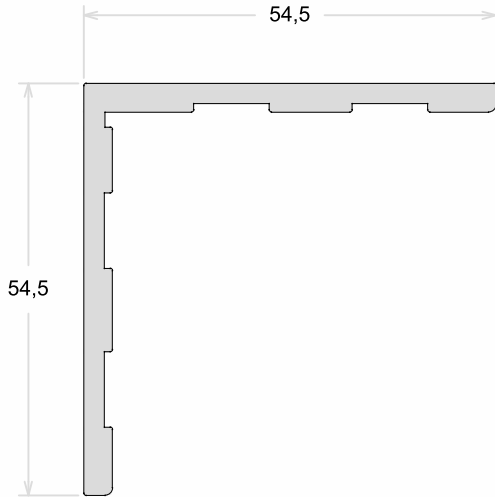

CL-036	Cunha 45°
Peso (Kg/m)	Perfis De Encaixe: Linha 20 Basculante / Módulo Maxim Ar
0,278	

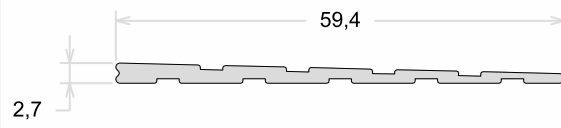

CL-006	Cantoneira 45°
Peso (Kg/m)	Perfis De Encaixe:
1,041	

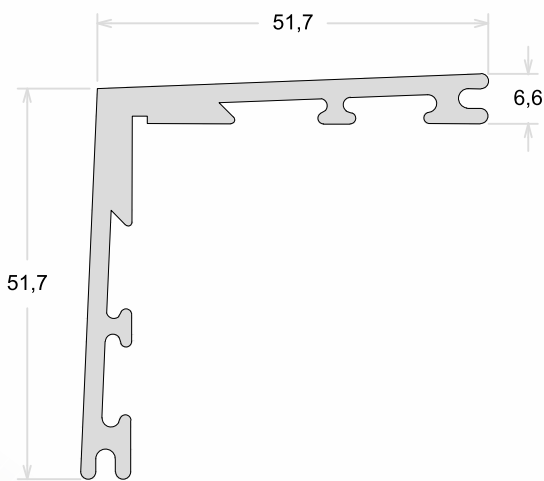

CL-011	Cunha 45°
Peso (Kg/m)	Perfis De Encaixe:
0,308	

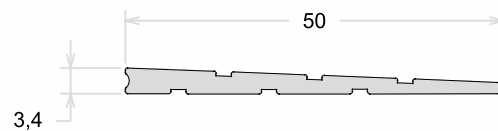

L-579	Cantoneira 45°
Peso (Kg/m)	Perfis De Encaixe:
1,014	

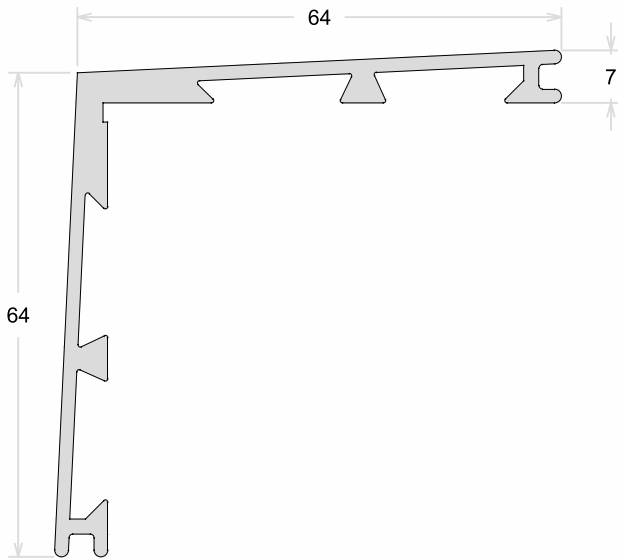

BAR-4037	Cunha 45°
Peso (Kg/m)	Perfis De Encaixe:
0,471	

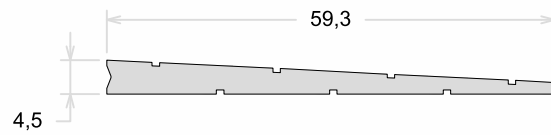

CM-1002	Contramarco
Peso (Kg/m)	Perfis De Encaixe:
0,263	

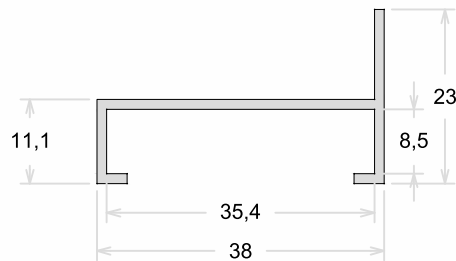

CM-063	CM-064	Contramarco
Peso (Kg/m)	Peso (Kg/m)	Perfis De Encaixe:
0,154	0,200	

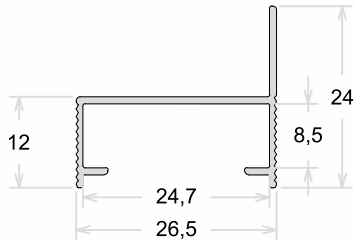

CM-151	Contramarco
Peso (Kg/m)	Perfis De Encaixe:
0,244	

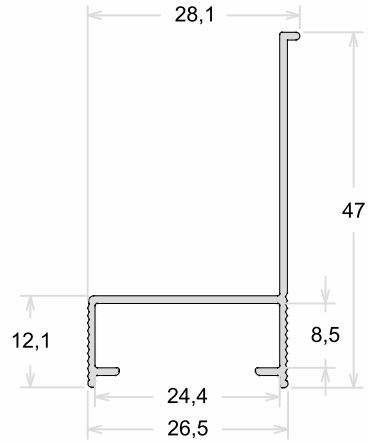

CM-060	Contramarco
Peso (Kg/m)	Perfis De Encaixe:
0,222	

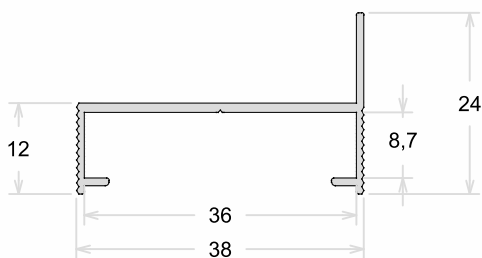

CM-098	Contramarco
Peso (Kg/m)	Perfis De Encaixe:
0,281	

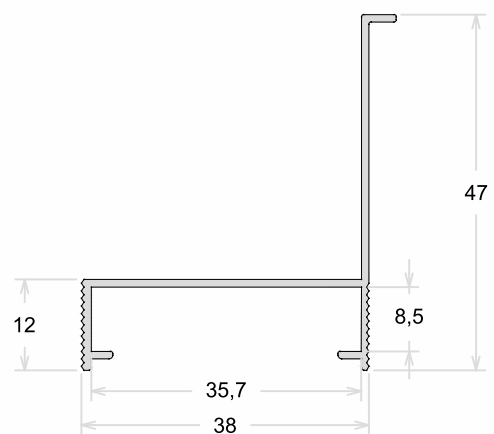

Y-1174	Contramarco
Peso (Kg/m)	Perfis De Encaixe:
0,369	

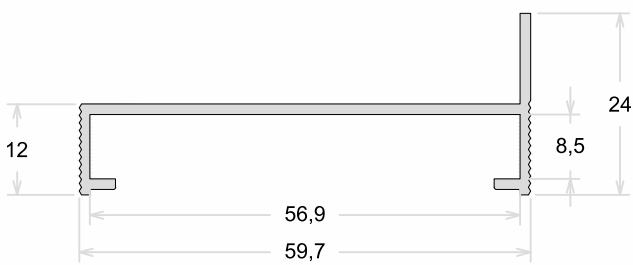

CM-173	Contramarco
Peso (Kg/m)	Perfis De Encaixe:
0,462	

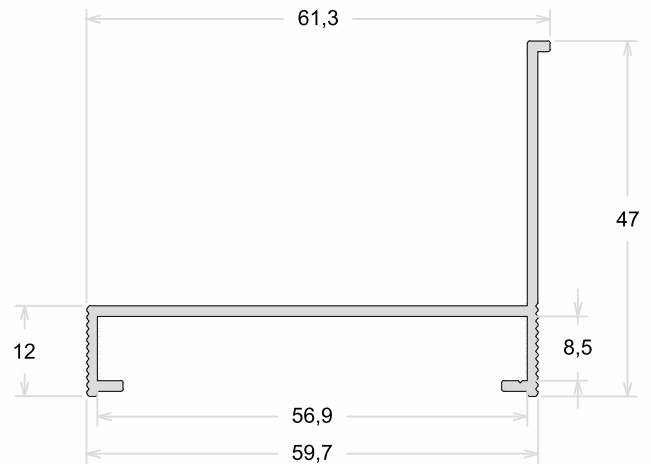

CM-175	Chumbador Contramarco
Peso (Kg/m)	Perfis De Encaixe:
0,610	

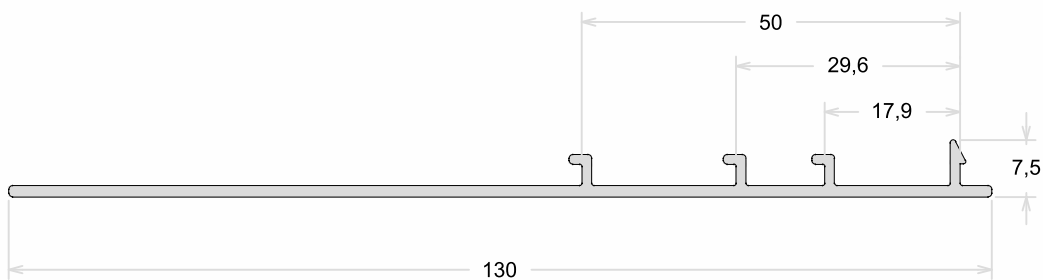

MP-348	Arremate
Peso (Kg/m)	Perfis De Encaixe:
0,174	

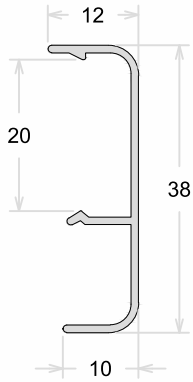

MP-3348	Arremate
Peso (Kg/m)	Perfis De Encaixe:
0,206	

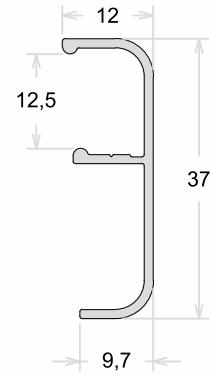

MP-347	MP-347S	Arremate
Peso (Kg/m)	Peso (Kg/m)	Perfis De Encaixe:
0,169	0,217	

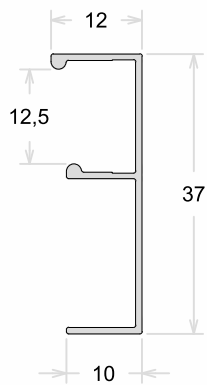

MN-014	Arremate
Peso (Kg/m)	Perfis De Encaixe:
0,197	

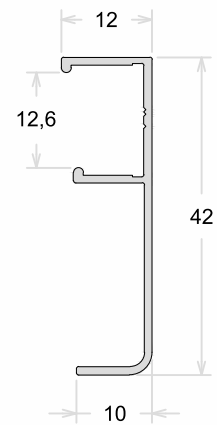

ME-092	Arremate Centro De Vão
Peso (Kg/m)	Perfis De Encaixe:
0,160	

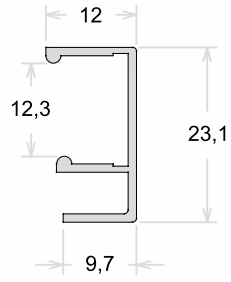

MP-346	Arremate
Peso (Kg/m)	Perfis De Encaixe:
0,302	

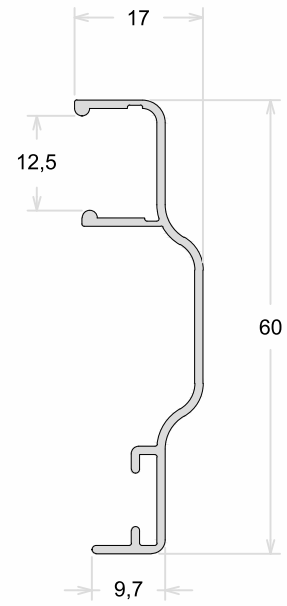

MP-349	Arremate
Peso (Kg/m)	Perfis De Encaixe:
0,298	

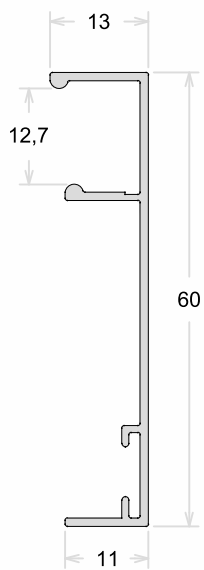

MP-350	Arremate
Peso (Kg/m)	Perfis De Encaixe:
0,268	

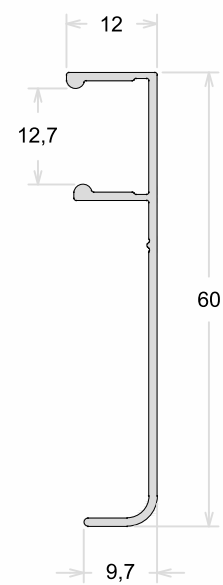

CM-008	Arremate
Peso (Kg/m)	Perfis De Encaixe:
0,148	

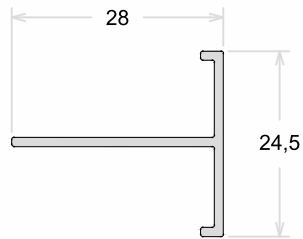

PEX-002	Arremate / Rodapé
Peso (Kg/m)	Perfis De Encaixe:
0,332	

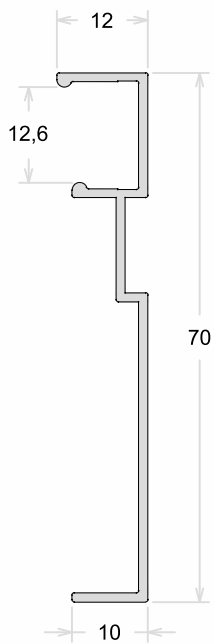

PEX-001	Arremate / Rodapé
Peso (Kg/m)	Perfis De Encaixe:
0,430	

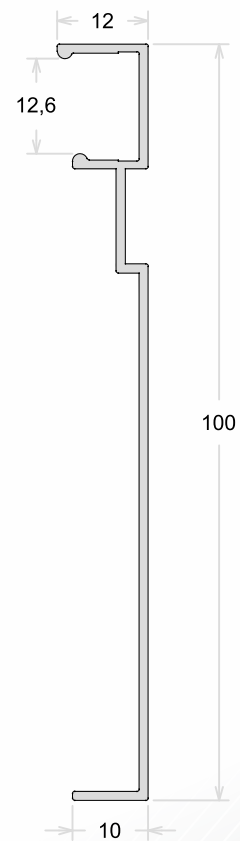

CX-905	Arremate De Piso
Peso (Kg/m)	Perfis De Encaixe:
0,186	

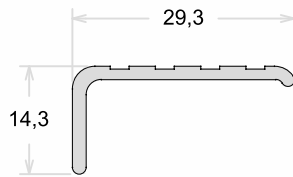

ME-013	Arremate De Piso
Peso (Kg/m)	Perfis De Encaixe:
0,252	

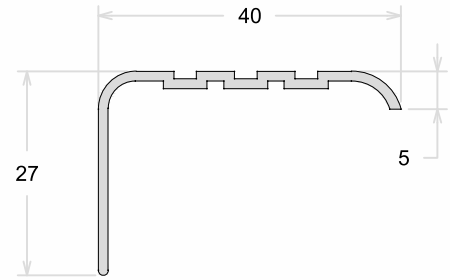

ME-015	Acabamento do Trilho
Peso (Kg/m)	Perfis De Encaixe:
0,220	

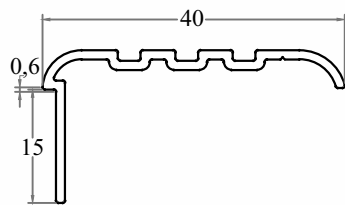

ME-014	Arremate De Piso
Peso (Kg/m)	Perfis De Encaixe:
0,275	

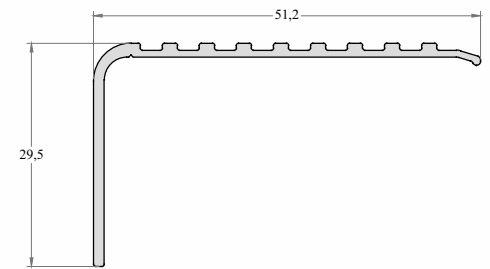

CX-827	Arremate De Piso
Peso (Kg/m)	Perfis De Encaixe:
0,158	

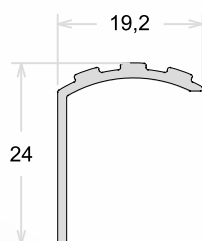

CX-662	Arremate De Piso
Peso (Kg/m)	Perfis De Encaixe:
0,279	

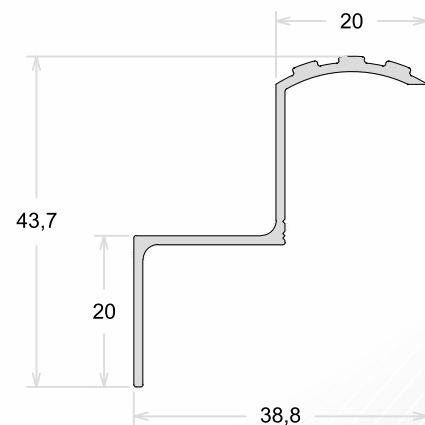

16-102	Marco Horizontal
Peso (Kg/m)	Perfis De Encaixe: 16-101 / 16-106
0,183	

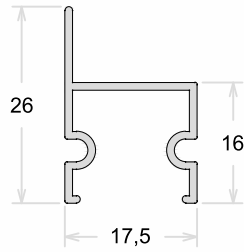

16-101	Marco Vertical
Peso (Kg/m)	Perfis De Encaixe: 16-102
0,244	

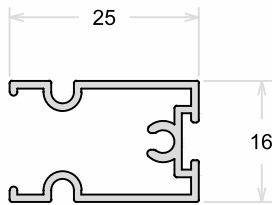

16-106	Montante Vertical e Horizontal
Peso (Kg/m)	Perfis De Encaixe: 16-102
0,325	

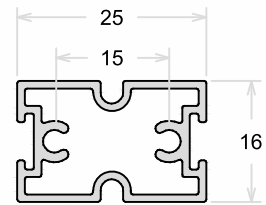

16-105	Folhas Basculante
Peso (Kg/m)	Perfis De Encaixe: 16-104
0,122	

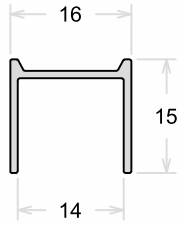

16-150	Folha Basculante
Peso (Kg/m)	Perfis De Encaixe: 16-107
0,133	

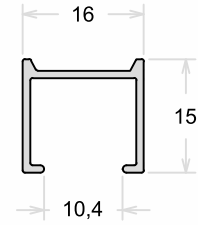

16-103	Folha Basculante
Peso (Kg/m)	Perfis De Encaixe: 16-104
0,156	

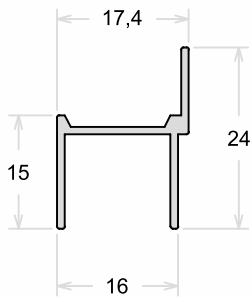

16-130	Folha Basculante
Peso (Kg/m)	Perfis De Encaixe: 16-107
0,170	

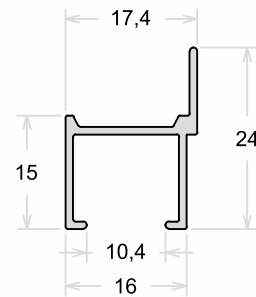

16-104	Folha Basculante
Peso (Kg/m)	Perfis De Encaixe:
0,154	

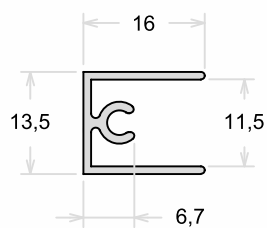

16-107	Folha Basculante
Peso (Kg/m)	Perfis De Encaixe:
0,211	

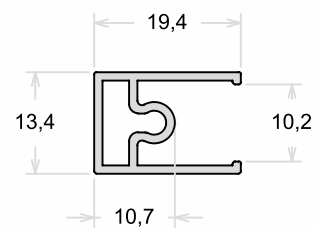

CL-007	Cantoneira 45°
Peso (Kg/m)	Perfis De Encaixe:
0,957	Linha 20 Basculante / Módulo Maxim Ar

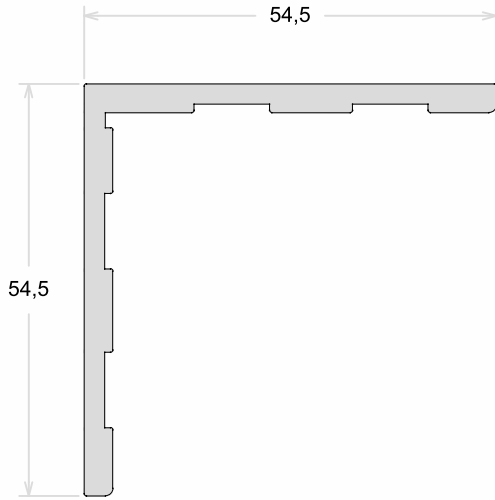

CL-036	Cunha 45°
Peso (Kg/m)	Perfis De Encaixe:
0,278	Linha 20 Basculante / Módulo Maxim Ar

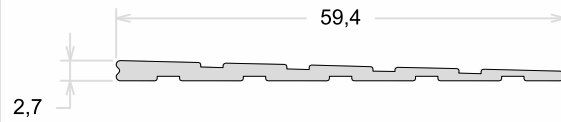

20-050	Marco Perimetral
Peso (Kg/m)	Perfis De Encaixe:
0,235	

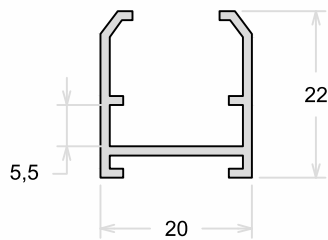

20-212	Marco Perimetral
Peso (Kg/m)	Perfis De Encaixe:
0,266	

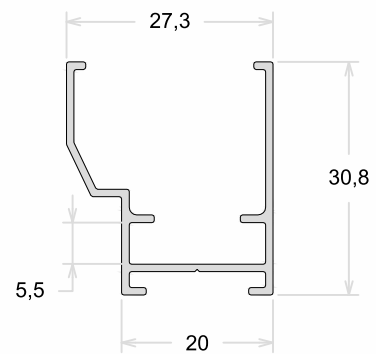

20-052	Montante Vertical
Peso (Kg/m)	Perfis De Encaixe: 20-054
0,199	

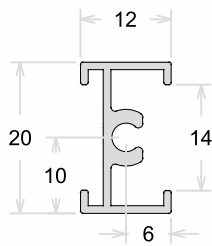

20-054	Montante Vertical
Peso (Kg/m)	Perfis De Encaixe: 20-052
0,199	

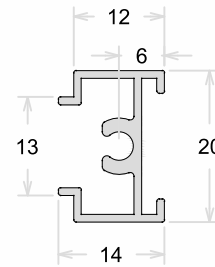

20-142	Haste Basculante
Peso (Kg/m)	Perfis De Encaixe:
0,387	

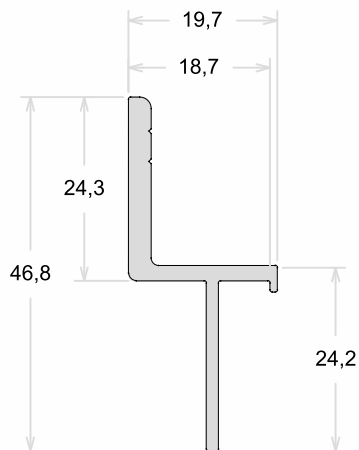

20-048	Folha Basculante
Peso (Kg/m)	Perfis De Encaixe: BG-001
0,320	

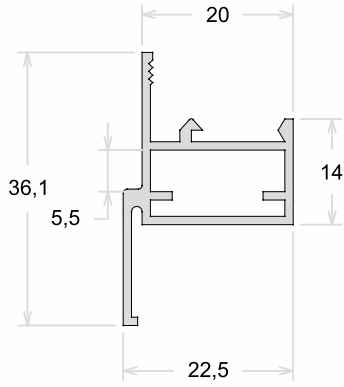

20-049	Folha Basculante
Peso (Kg/m)	Perfis De Encaixe: BG-001
0,298	

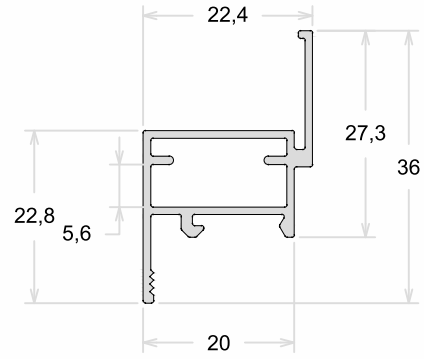

20-051	Folha Basculante
Peso (Kg/m)	Perfis De Encaixe: BG-001
0,233	

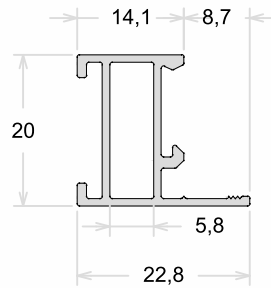

20-053	Complemento
Peso (Kg/m)	Perfis De Encaixe: Folhas, BG-001 e Marco
0,143	

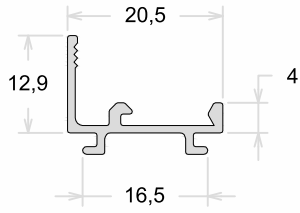

20-055	Complemento
Peso (Kg/m)	Perfis De Encaixe: Folhas e Marcos
0,135	

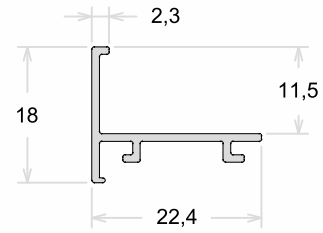

BG-001	Baguete Perimetral
Peso (Kg/m)	Perfis De Encaixe: Folhas e Complemento
0,091	

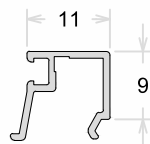

MP-357	Marco Superior
Peso (Kg/m)	Perfis De Encaixe:
0,591	

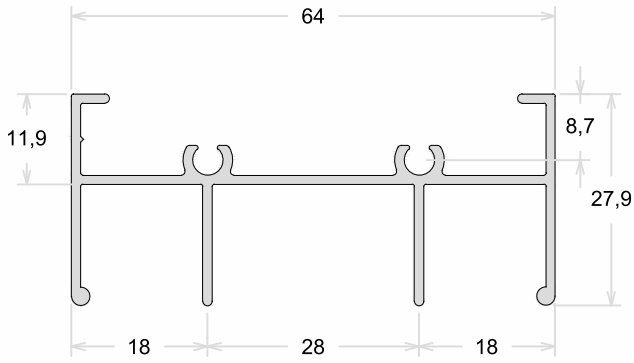

MP-388	Travessa Bandeira
Peso (Kg/m)	Perfis De Encaixe:
0,907	

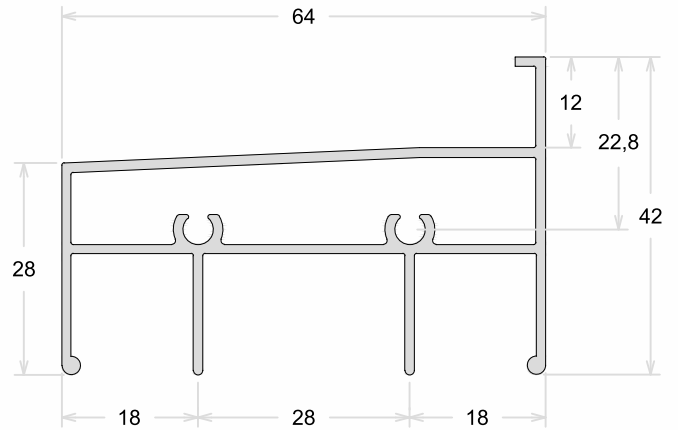

MP-358	Marco Inferior
Peso (Kg/m)	Perfis De Encaixe:
0,544	

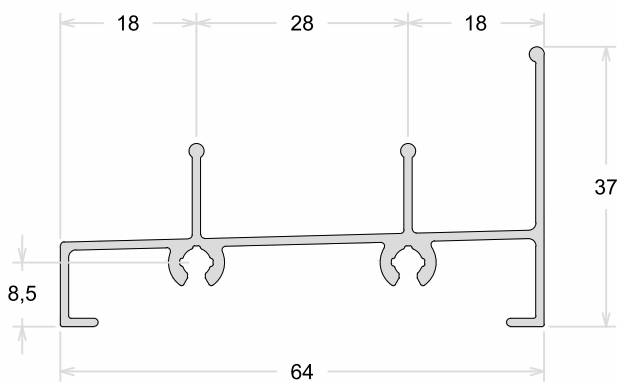

MP-370	Marco Inferior
Peso (Kg/m)	Perfis De Encaixe:
0,504	

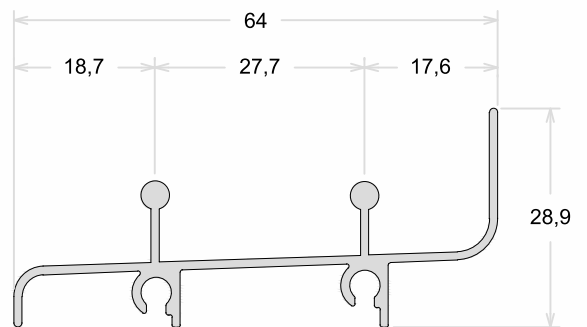

MP-360	Marco Lateral
Peso (Kg/m)	Perfis De Encaixe:
0,407	

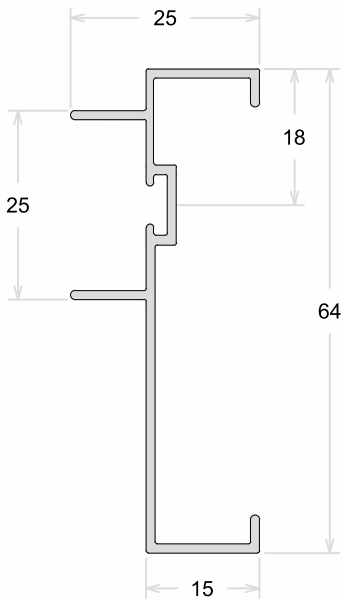

MP-397	Marco Lateral
Peso (Kg/m)	Perfis De Encaixe:
0,376	

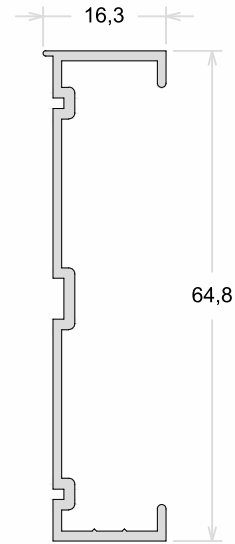

MP-363	Marco Bandeira / Peitoril
Peso (Kg/m)	Perfis De Encaixe:
0,468	

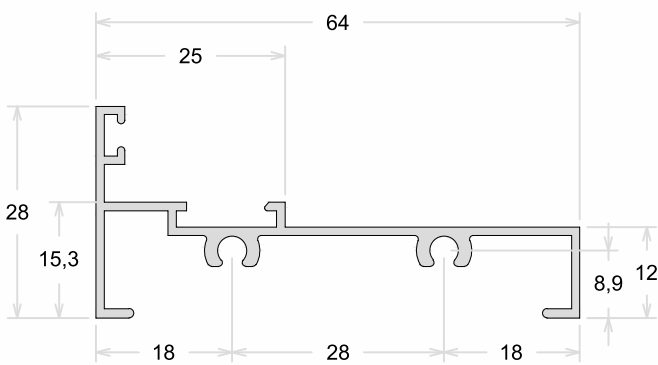

MP-389	Marco Bandeira / Peitoril
Peso (Kg/m)	Perfis De Encaixe:
0,445	

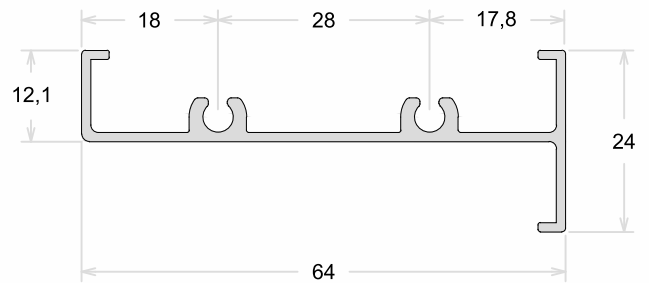

MP-368	Marco Lateral
Peso (Kg/m)	Perfis De Encaixe:
0,610	

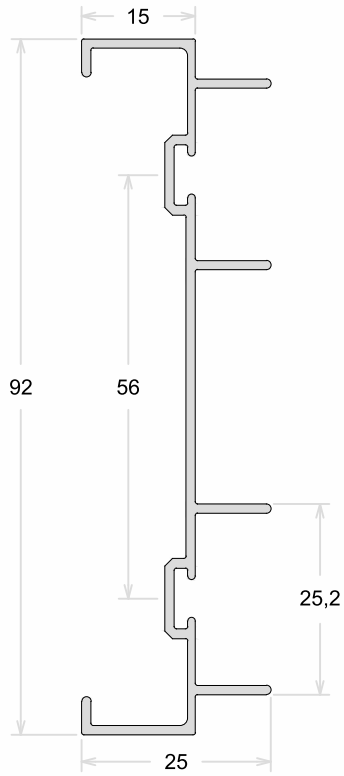

MP-369	Marco Lateral
Peso (Kg/m)	Perfis De Encaixe:
0,520	

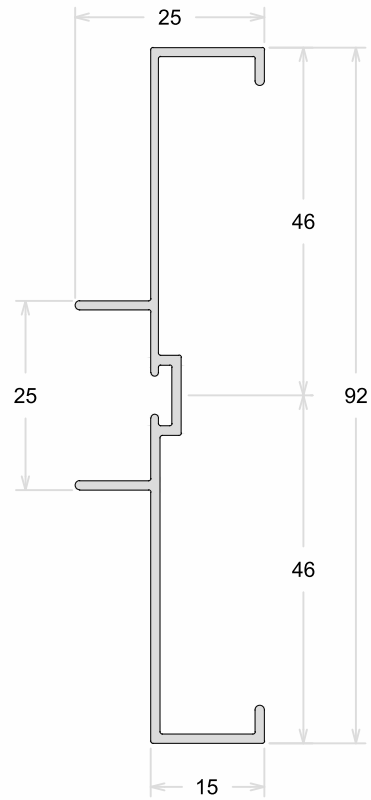

MP-352	Mata Junta
Peso (Kg/m)	Perfis De Encaixe:
0,199	

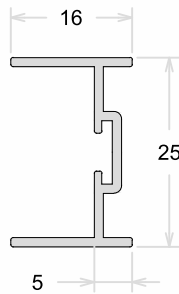

MP-309	Folha Horizontal
Peso (Kg/m)	Perfis De Encaixe:
0,370	

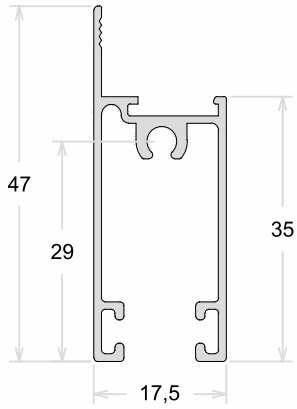

MP-378	Folha Horizontal
Peso (Kg/m)	Perfis De Encaixe:
0,350	

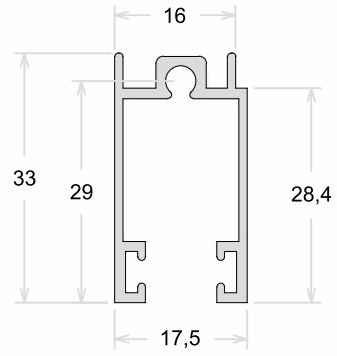

MP-354	Folha Inferior - Porta
Peso (Kg/m)	Perfis De Encaixe:
0,933	

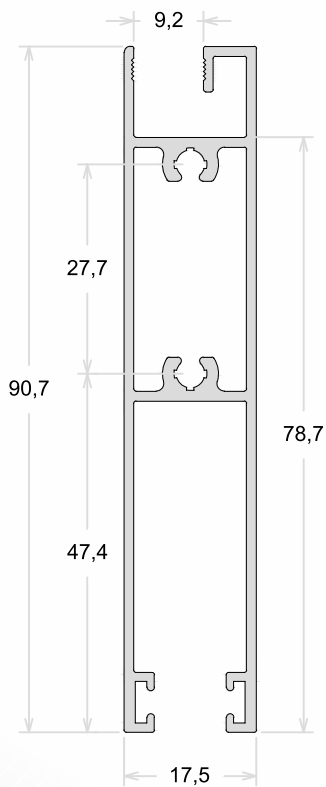

MP-332	Travessa Horizontal 60mm
Peso (Kg/m)	Perfis De Encaixe:
0,531	

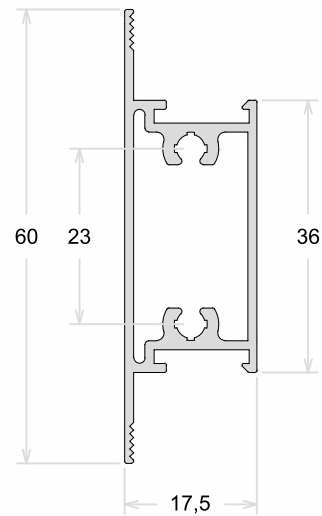

MP-300	Folha Lateral
Peso (Kg/m)	Perfis De Encaixe:
0,313	

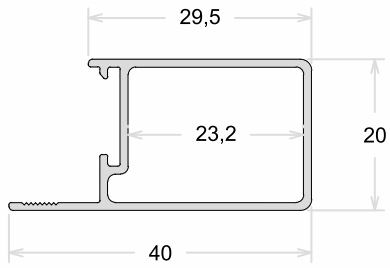

MP-373	Folha Lateral Fixa
Peso (Kg/m)	Perfis De Encaixe:
0,409	

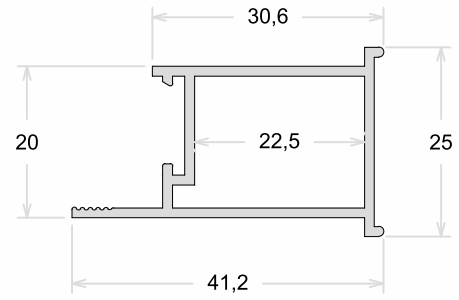

MP-318	Folha Central
Peso (Kg/m)	Perfis De Encaixe:
0,466	

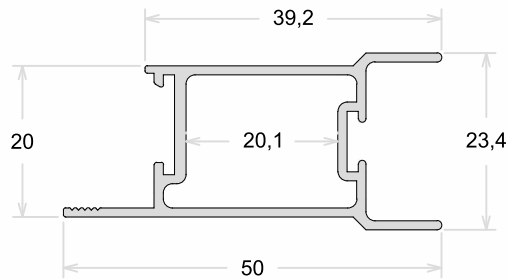

MP-321	Folha Mão De Amigo Int. C/ Reforço
Peso (Kg/m)	Perfis De Encaixe:
0,406	

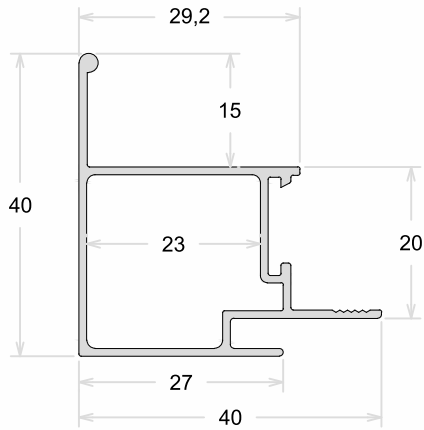

MP-302	Folha Mão De Amigo Externo
Peso (Kg/m)	Perfis De Encaixe:
0,406	

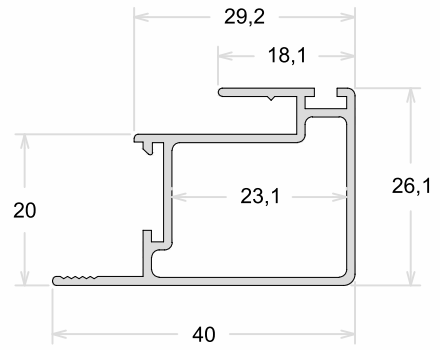

MP-305	Folha Lateral Veneziana
Peso (Kg/m)	Perfis De Encaixe:
0,369	

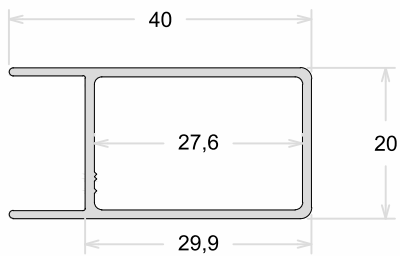

MP-303	Folha Mão De Amigo Veneziana
Peso (Kg/m)	Perfis De Encaixe:
0,387	

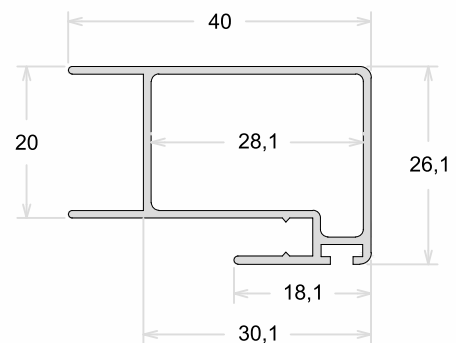

MP-336	Folha Lateral
Peso (Kg/m)	Perfis De Encaixe:
0,452	

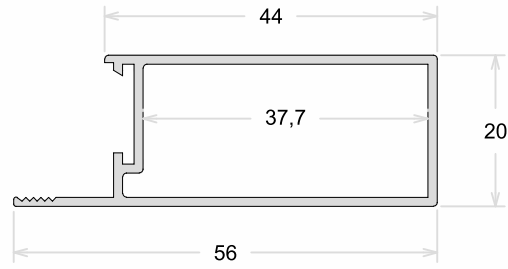

MP-069	Folha Mão De Amigo Int. C/ Reforço
Peso (Kg/m)	Perfis De Encaixe:
0,632	

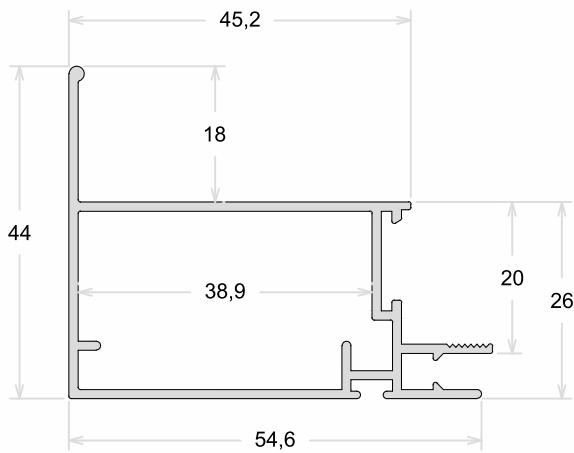

MP-070	Folha Mão De Amigo Externo
Peso (Kg/m)	Perfis De Encaixe:
0,505	

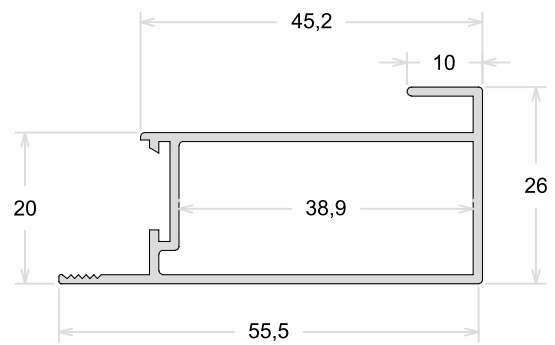

BG-202	Baguete Horizontal
Peso (Kg/m)	Perfis De Encaixe:
0,098	

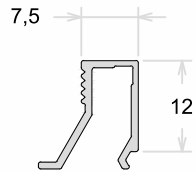

BG-101	Baguete Vertical
Peso (Kg/m)	Perfis De Encaixe:
0,094	

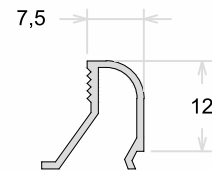

VZ-024	Veneziana
Peso (Kg/m)	Perfis De Encaixe:
0,207	

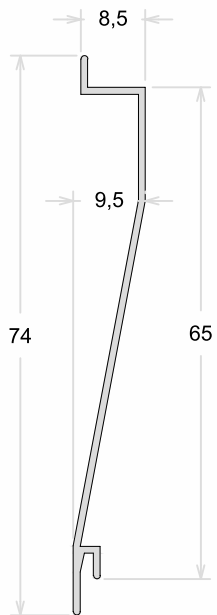

VZ-024 VT	Veneziana Ventilada
Peso (Kg/m)	Perfis De Encaixe:
0,252	

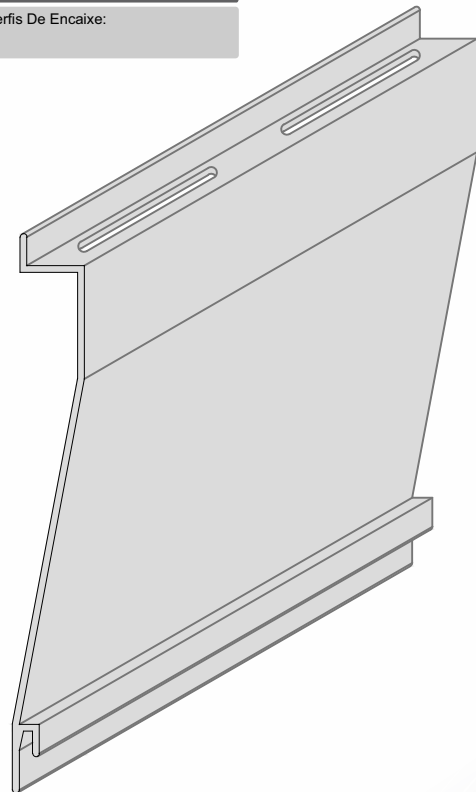

E-290	Marco Superior
Peso (Kg/m)	Perfis De Encaixe:
0,853	

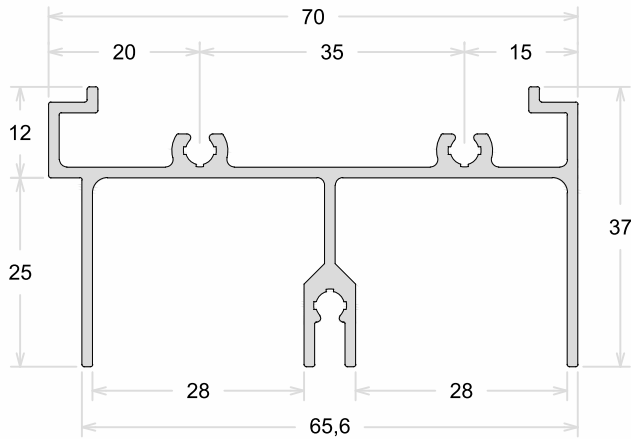

25-703	Guia Do Portão De Correr
Peso (Kg/m)	Perfis De Encaixe:
0,989	

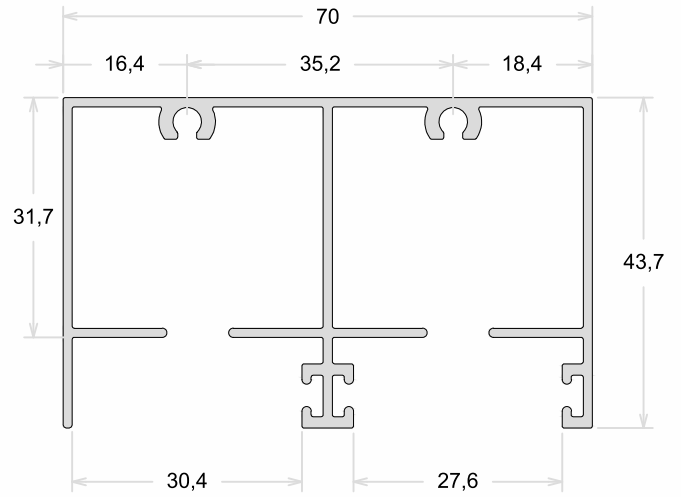

25-516	Marco Inferior
Peso (Kg/m)	Perfis De Encaixe:
0,739	

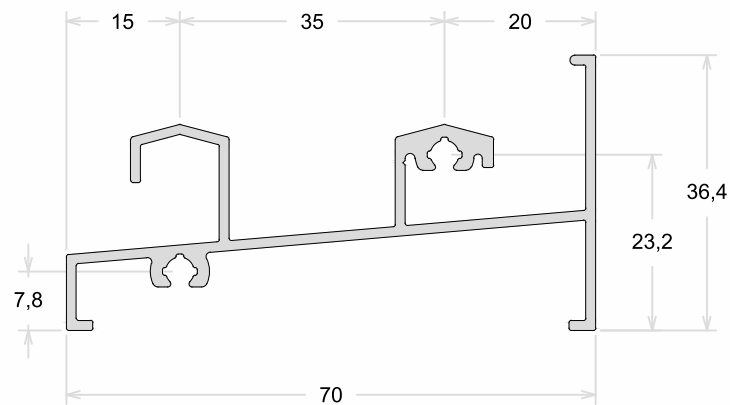

25-514	Marco Lateral
Peso (Kg/m)	Perfis De Encaixe:
0,409	

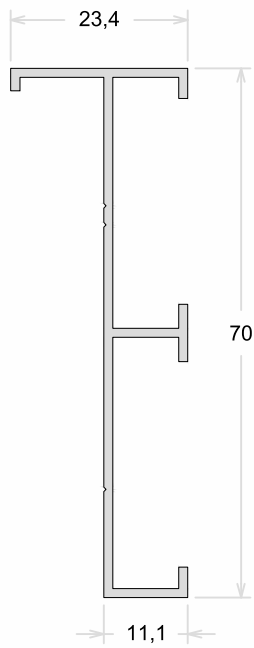

Z-175	Marco Bandeira / Peitoril
Peso (Kg/m)	Perfis De Encaixe:
0,539	

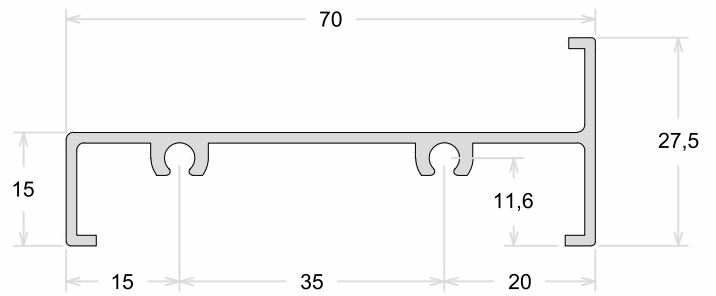

25-021	Mata Junta
Peso (Kg/m)	Perfis De Encaixe:
0,204	

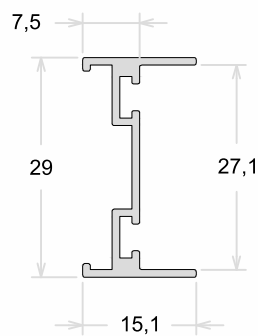

Y-195	Folha Horizontal
Peso (Kg/m)	Perfis De Encaixe:
0,474	

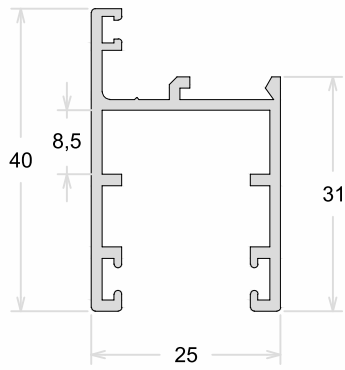

25-502	Folha Horizontal
Peso (Kg/m)	Perfis De Encaixe:
0,596	

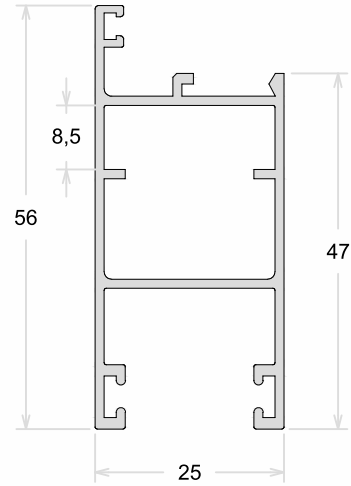

25-016	Folha Lateral
Peso (Kg/m)	Perfis De Encaixe:
0,404	

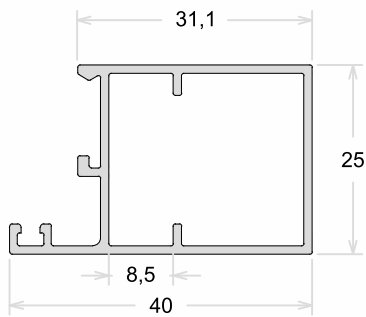

25-504	Folha Lateral
Peso (Kg/m)	Perfis De Encaixe:
0,533	

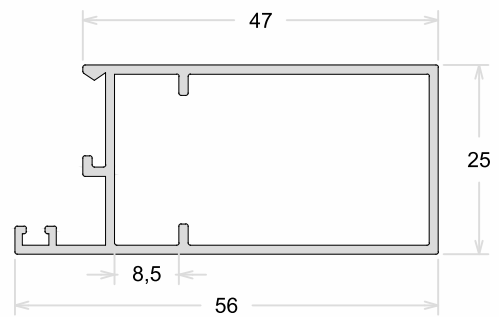

25-506	Folha Mão De Amigo Interno
Peso (Kg/m)	Perfis De Encaixe:
0,639	

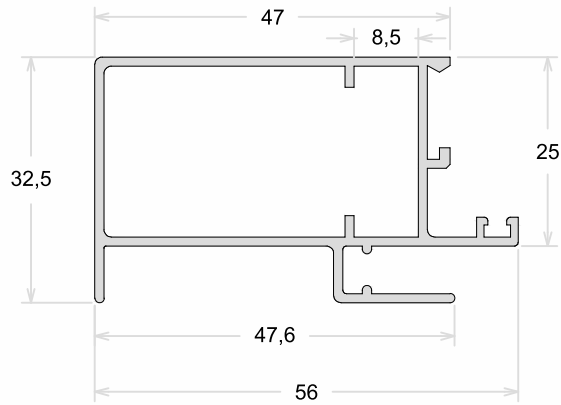

25-507	Folha Mão De Amigo Externo
Peso (Kg/m)	Perfis De Encaixe:
0,614	

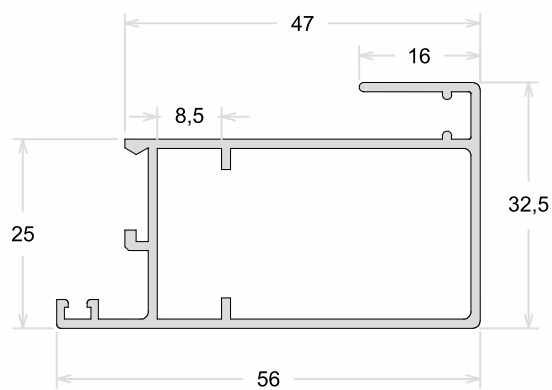

25-027	Marco Fixo
Peso (Kg/m)	Perfis De Encaixe:
0,252	

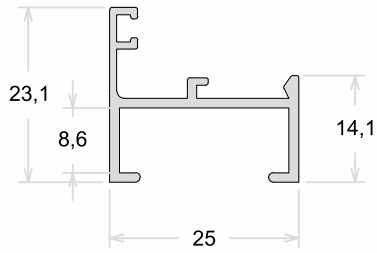

25-002	Marco Perimetral
Peso (Kg/m)	Perfis De Encaixe:
0,328	

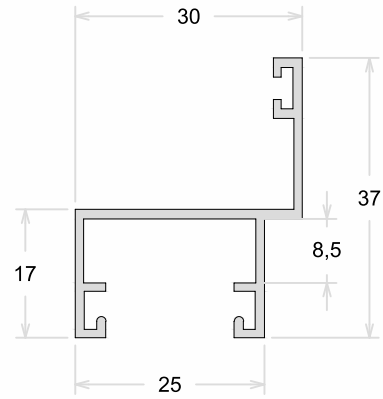

25-022	Marco Perimetral
Peso (Kg/m)	Perfis De Encaixe:
0,403	

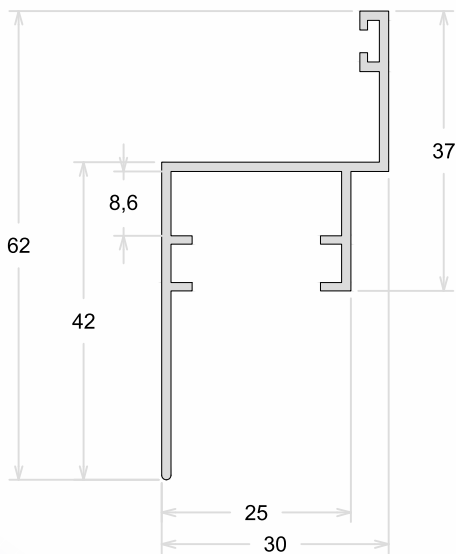

25-102	Marco Tubular
Peso (Kg/m)	Perfis De Encaixe:
0,410	

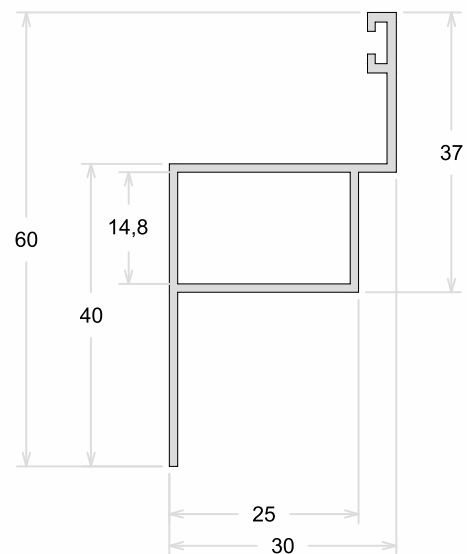

25-023	Coluna
Peso (Kg/m)	Perfis De Encaixe:
0,549	

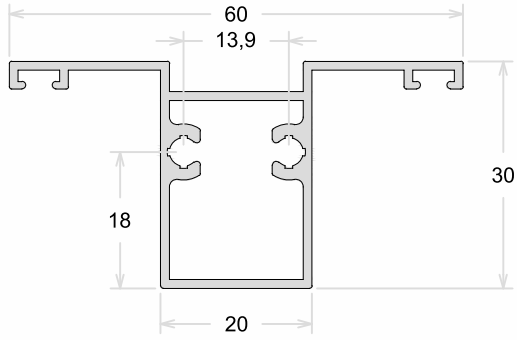

CL-015	Pingadeira
Peso (Kg/m)	Perfis De Encaixe:
0,217	

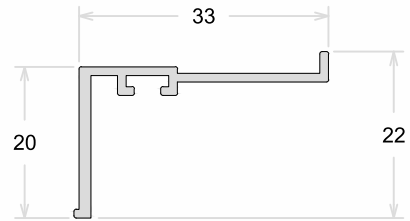

25-001	Folha Maxim Ar
Peso (Kg/m)	Perfis De Encaixe:
0,273	

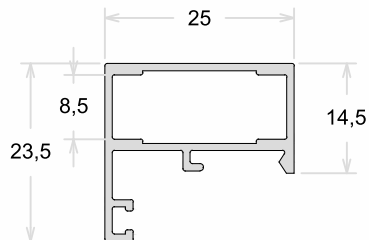

25-005	Folha Maxim Ar
Peso (Kg/m)	Perfis De Encaixe:
0,380	

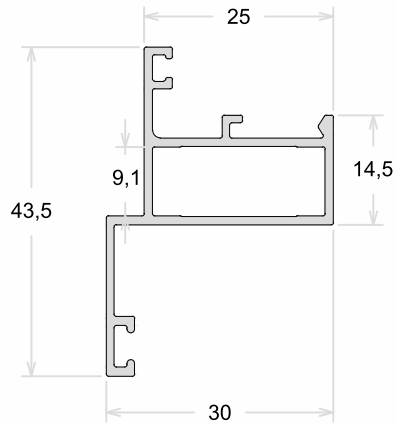

P-167	Folha Maxim Ar
Peso (Kg/m)	Perfis De Encaixe:
0,378	

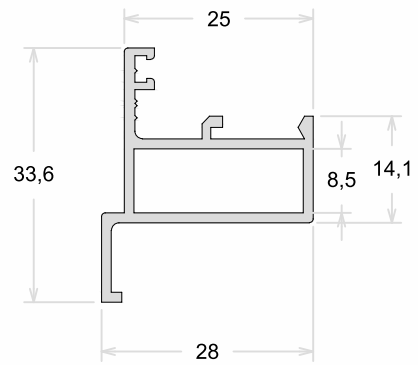

25-018	Folha Maxim Ar
Peso (Kg/m)	Perfis De Encaixe:
0,426	

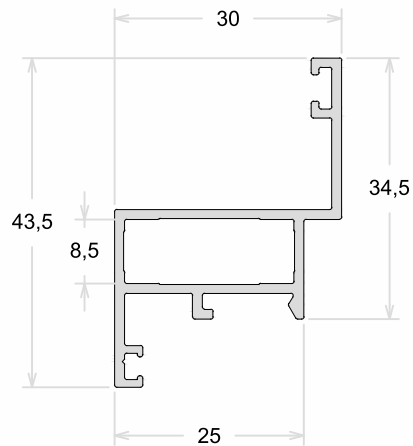

25-059	Marco - Porta De Giro
Peso (Kg/m)	Perfis De Encaixe:
0,390	

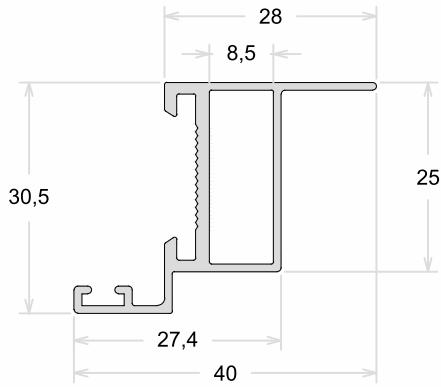

25-540	Marco - Porta De Giro
Peso (Kg/m)	Perfis De Encaixe:
0,440	

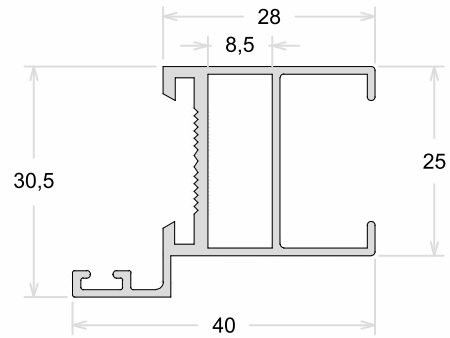

25-541	Marco Tubular
Peso (Kg/m)	Perfis De Encaixe:
0,436	

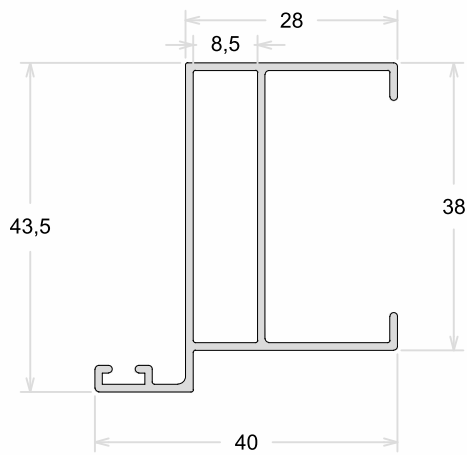

25-548	Batente - Porta De Giro
Peso (Kg/m)	Perfis De Encaixe:
0,221	

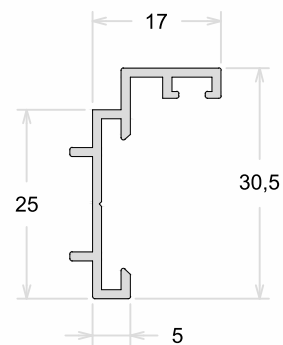

25-542	Folha - Porta De Giro
Peso (Kg/m)	Perfis De Encaixe:
0,565	

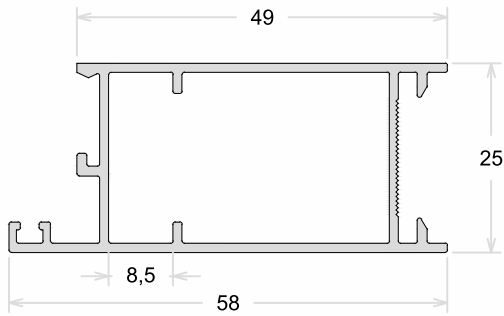

25-543	Folha - Porta De Giro
Peso (Kg/m)	Perfis De Encaixe:
0,728	

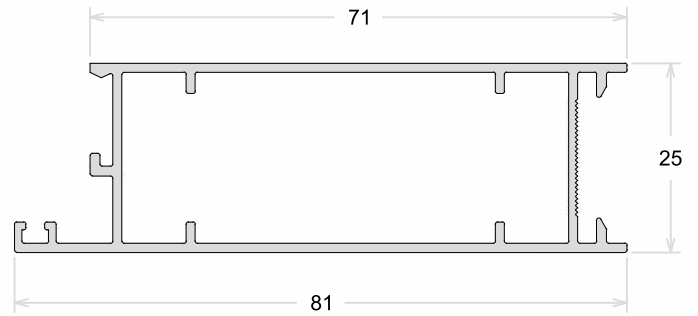

25-544	Folha - Porta De Giro
Peso (Kg/m)	Perfis De Encaixe:
0,597	

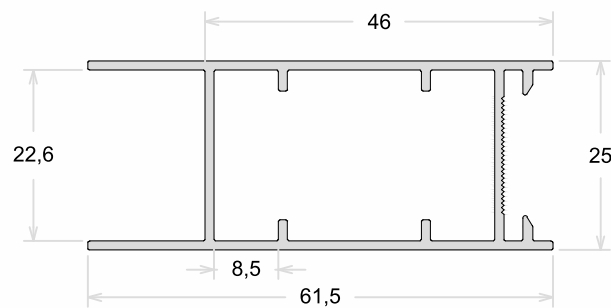

25-026	P-153	Travessa 40mm
Peso (Kg/m)	Peso (Kg/m)	Perfis De Encaixe:
0,474	0,529	

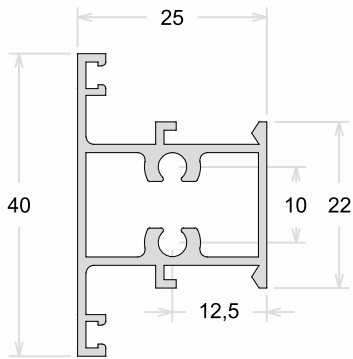

25-508	Travessa 56mm
Peso (Kg/m)	Perfis De Encaixe:
0,594	

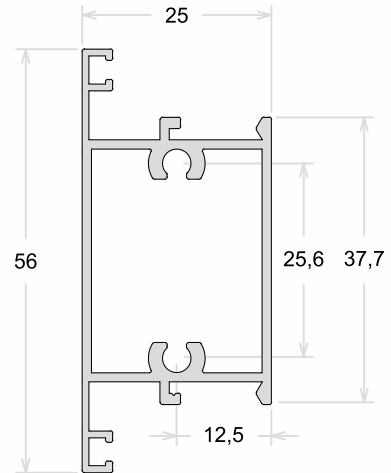

DS-036	Porta Palheta
Peso (Kg/m)	Perfis De Encaixe:
0,152	

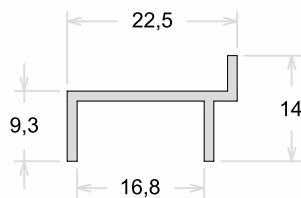

CL-050	Complemento
Peso (Kg/m)	Perfis De Encaixe:
0,133	

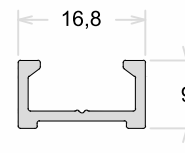

Z-163	Veneziana
Peso (Kg/m)	Perfis De Encaixe:
0,258	

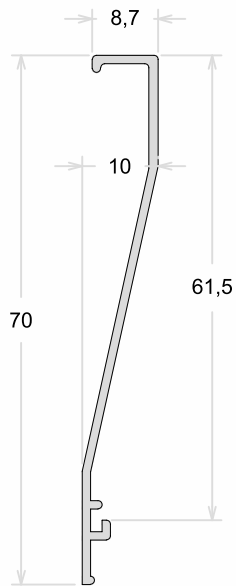

CX-642	Veneziana
Peso (Kg/m)	Perfis De Encaixe:
0,228	



VZ-024	Veneziana
Peso (Kg/m)	Perfis De Encaixe:
0,207	

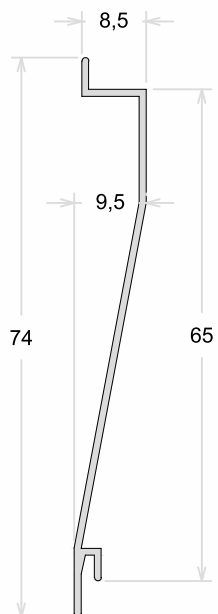

VZ-024 VT	Veneziana Ventilada
Peso (Kg/m)	Perfis De Encaixe:
0,252	

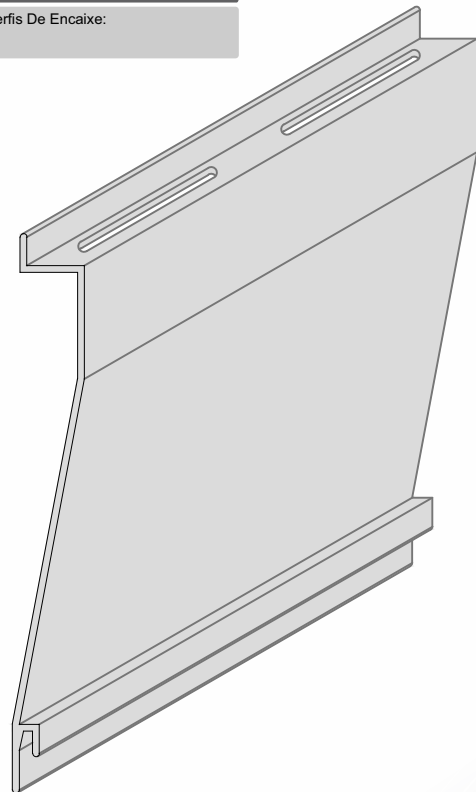

VZ-023	Veneziana
Peso (Kg/m)	Perfis De Encaixe:
0,240	

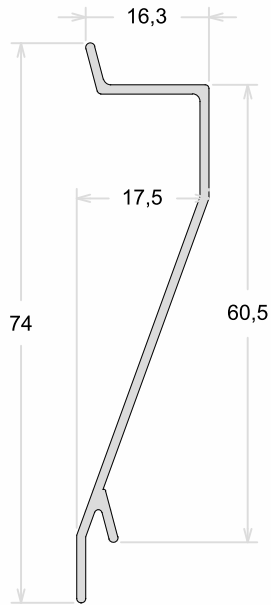

VZ-023 VT	Veneziana Ventilada
Peso (Kg/m)	Perfis De Encaixe:
0,240	

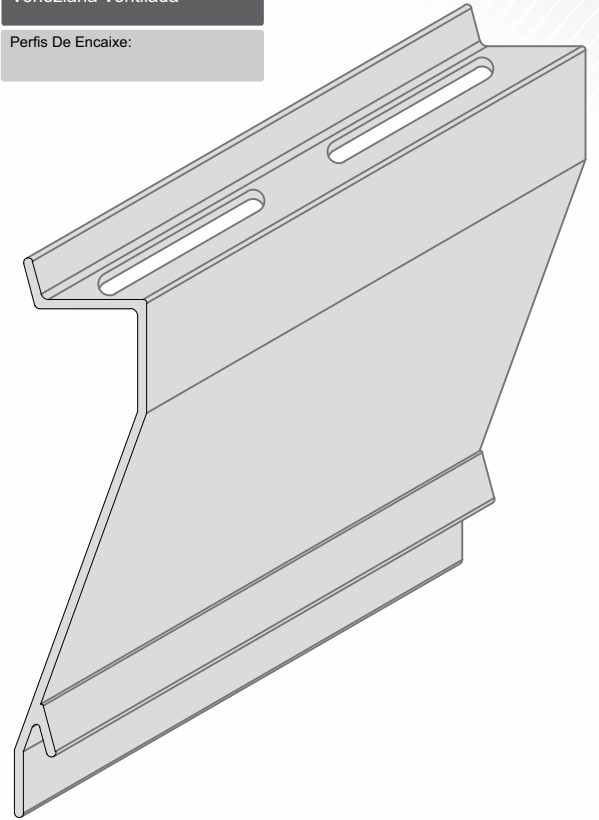

VZ-082	Veneziana
Peso (Kg/m)	Perfis De Encaixe:
0,280	

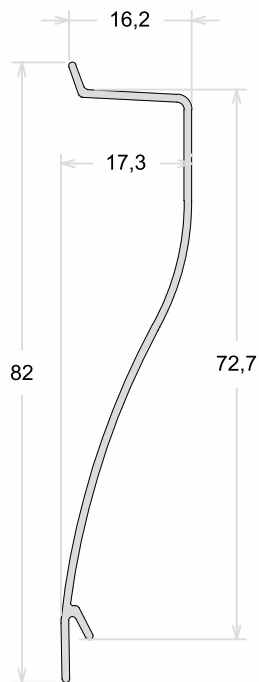

VZ-082 VT	Veneziana Ventilada
Peso (Kg/m)	Perfis De Encaixe:
0,280	

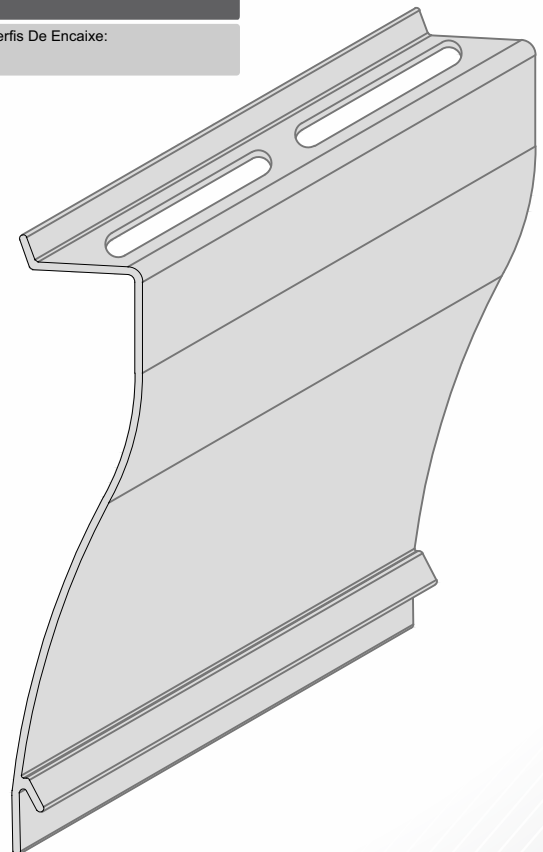

P-822	Marco Inferior
Peso (Kg/m)	Perfis De Encaixe:
0,604	

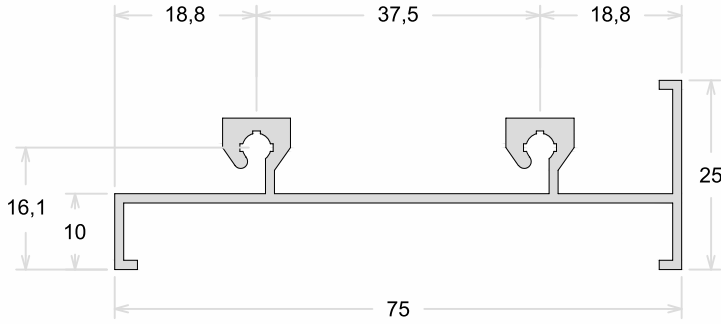

Y-487	Marco Inferior
Peso (Kg/m)	Perfis De Encaixe:
0,593	

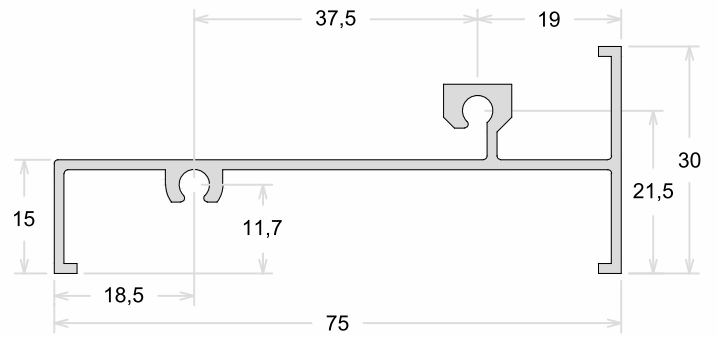

P-817	Marco Bandeira / Peitoril
Peso (Kg/m)	Perfis De Encaixe:
0,648	

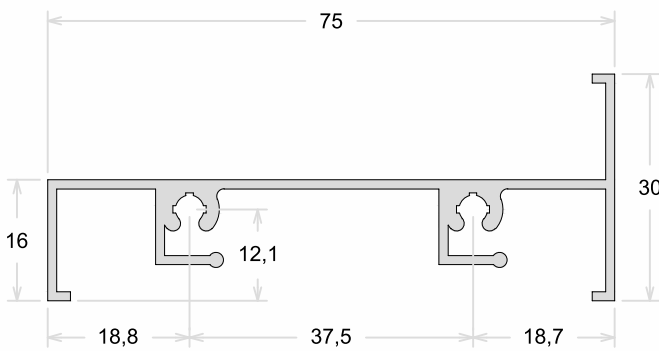

P-818	Marco Bandeira / Peitoril
Peso (Kg/m)	Perfis De Encaixe:
0,525	

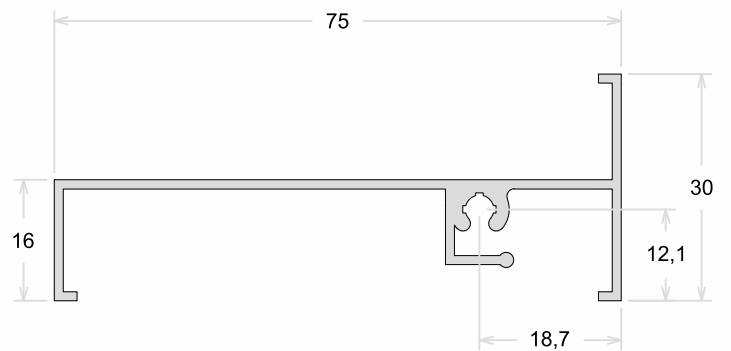

P-816	Marco Bandeira / Peitoril
Peso (Kg/m)	Perfis De Encaixe:
0,560	

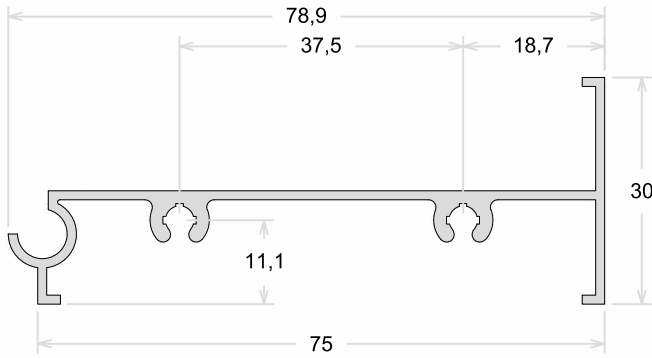

P-205	Coluna
Peso (Kg/m)	Perfis De Encaixe:
0,902	

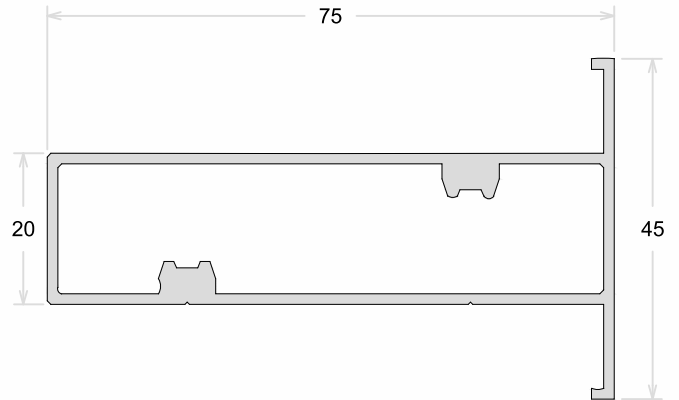

Y-301	Marco Lateral
Peso (Kg/m)	Perfis De Encaixe:
0,431	

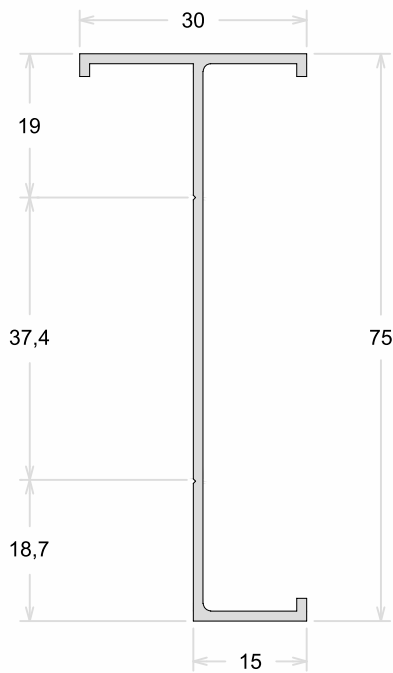

Y-632	Marco Lateral
Peso (Kg/m)	Perfis De Encaixe:
0,398	

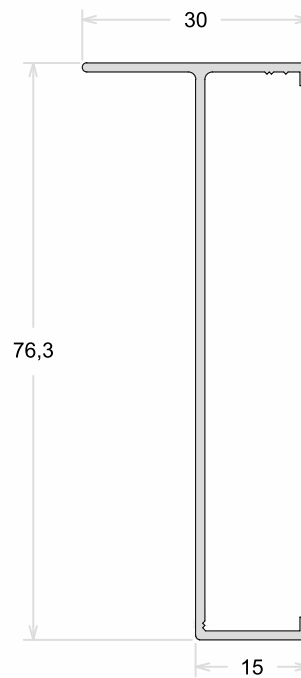

Y-625	Folha Horizontal
Peso (Kg/m)	Perfis De Encaixe:
0,385	

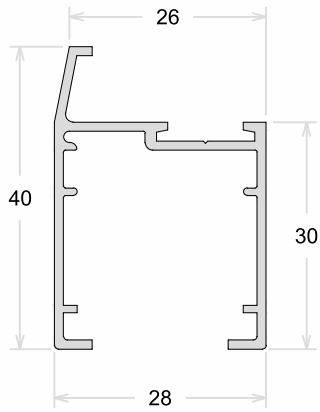

P-513	Folha Lateral
Peso (Kg/m)	Perfis De Encaixe:
0,434	

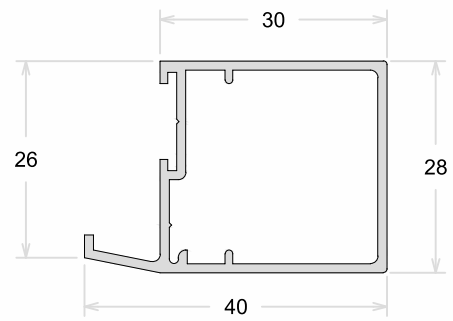

P-514	Folha Mão De Amigo Interno
Peso (Kg/m)	Perfis De Encaixe:
0,479	

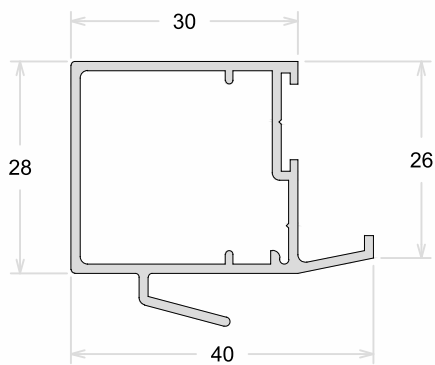

P-515	Folha Mão De Amigo Externo
Peso (Kg/m)	Perfis De Encaixe:
0,479	

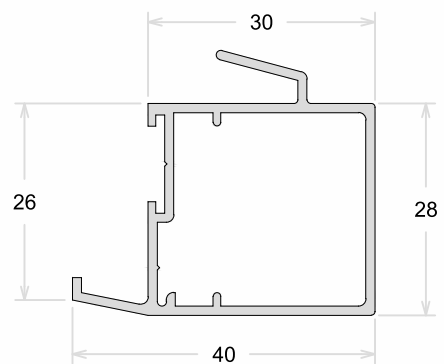

P-530	Folha Lateral
Peso (Kg/m)	Perfis De Encaixe:
0,538	

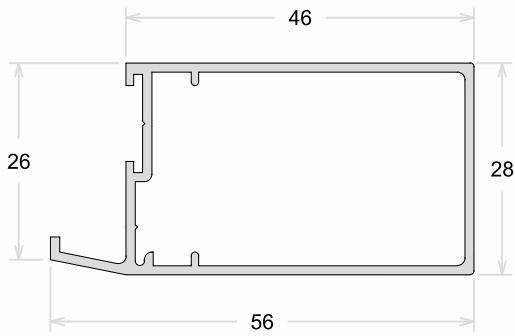

U-804	Baguete Perimetral
Peso (Kg/m)	Perfis De Encaixe:
0,100	

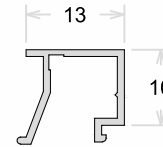

U-992	Marco Maxim Ar
Peso (Kg/m)	Perfis De Encaixe:
0,214	

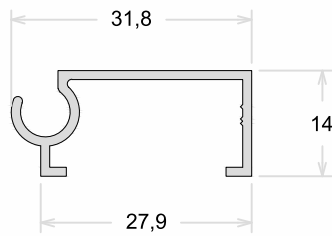

P-519	Folha Maxim Ar
Peso (Kg/m)	Perfis De Encaixe:
0,375	

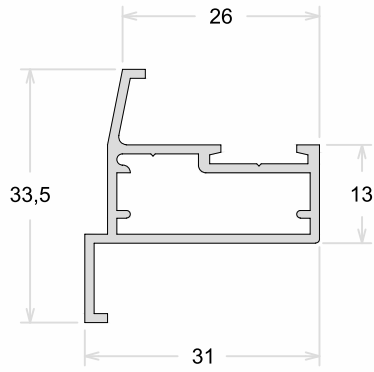

P-518	Folha Maxim Ar
Peso (Kg/m)	Perfis De Encaixe:
0,375	

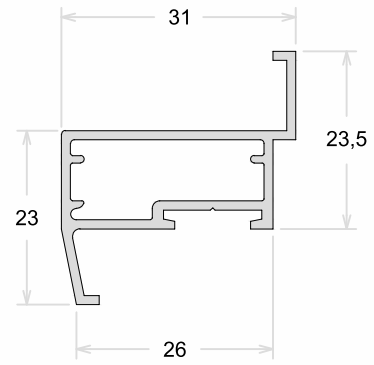

P-517	Folha Maxim Ar
Peso (Kg/m)	Perfis De Encaixe:
0,326	

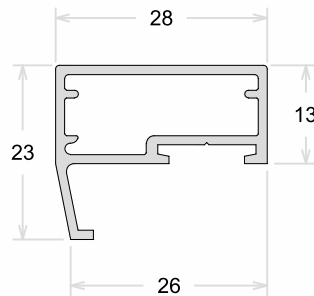

30-023	Marco - Porta De Giro
Peso (Kg/m)	Perfis De Encaixe:
0,527	

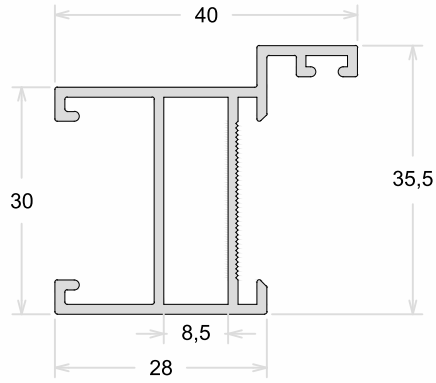

30-035	Marco - Porta De Giro
Peso (Kg/m)	Perfis De Encaixe:
0,951	

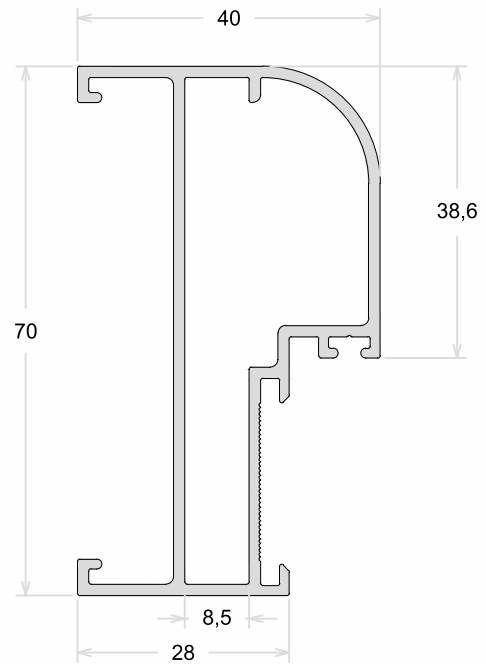

P-272	Marco - Porta De Giro
Peso (Kg/m)	Perfis De Encaixe:
0,751	

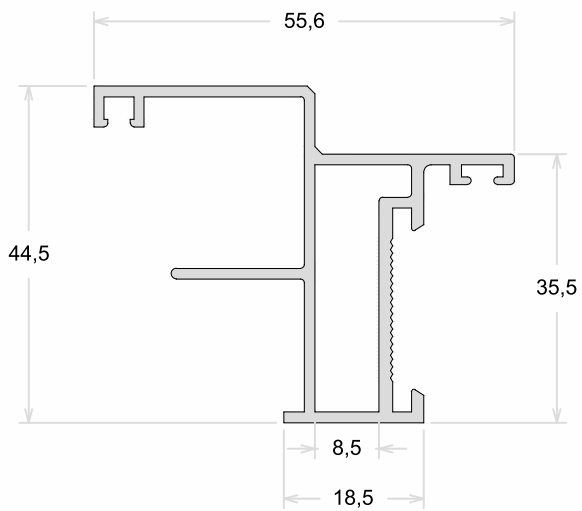

30-034	Batente - Porta De Giro
Peso (Kg/m)	Perfis De Encaixe:
0,261	

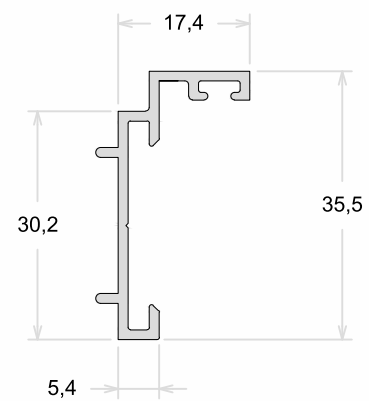

P-084	Folha Portinhola
Peso (Kg/m)	Perfis De Encaixe:
0,527	

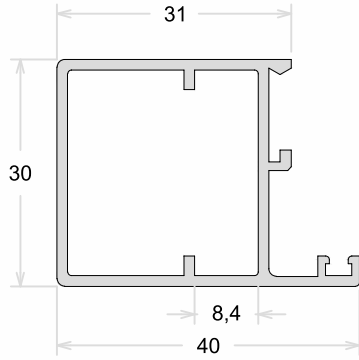

P-068	Folha Portinhola
Peso (Kg/m)	Perfis De Encaixe:
0,695	

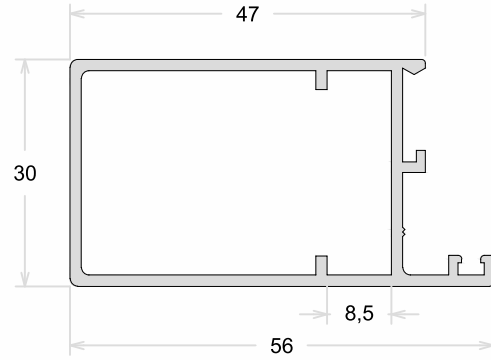

A-144	Folha - Porta De Giro
Peso (Kg/m)	Perfis De Encaixe:
0,766	

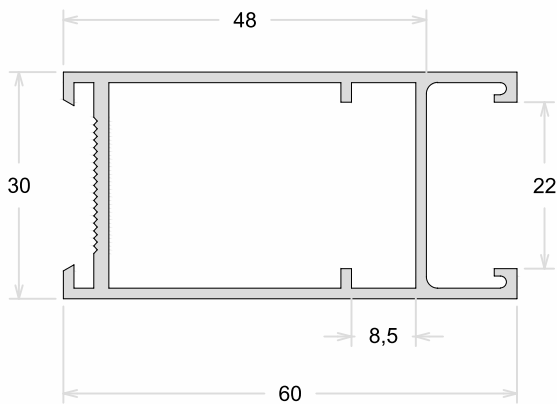

PPO-005	Folha - Porta De Giro
Peso (Kg/m)	Perfis De Encaixe:
0,712	

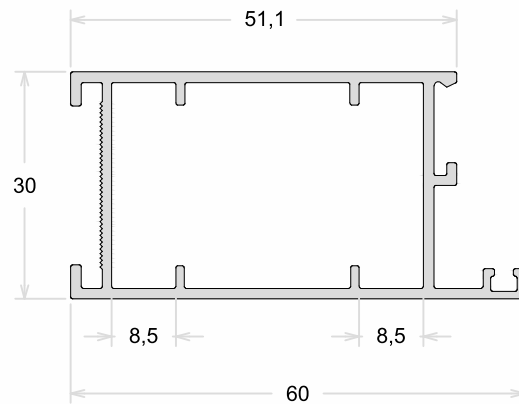

P-264	Folha - Porta De Giro
Peso (Kg/m)	Perfis De Encaixe:
1,124	

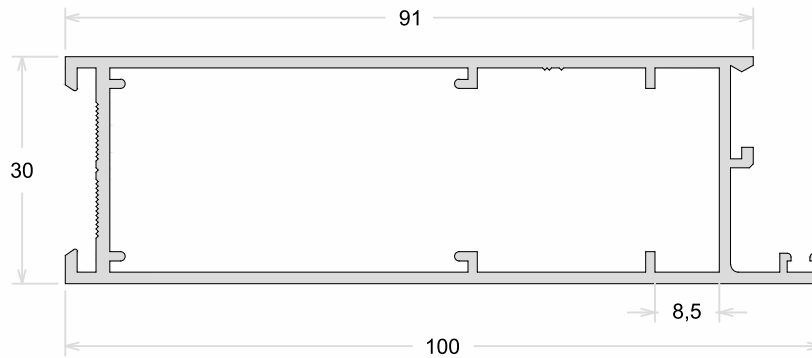

PPO-003	Folha - Porta De Giro
Peso (Kg/m)	Perfis De Encaixe:
1,124	

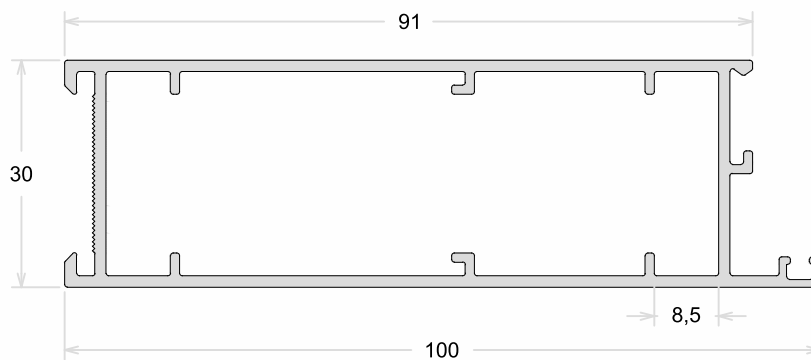

30-040	Montante 100mm Porta de Giro
Peso (Kg/m)	Perfis De Encaixe:
1,010	

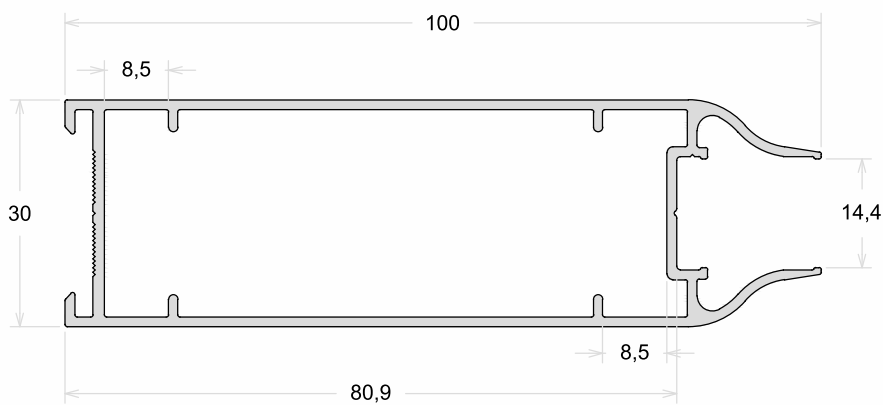

ME-075	Folha - Porta De Giro
Peso (Kg/m)	Perfis De Encaixe:
0,978	

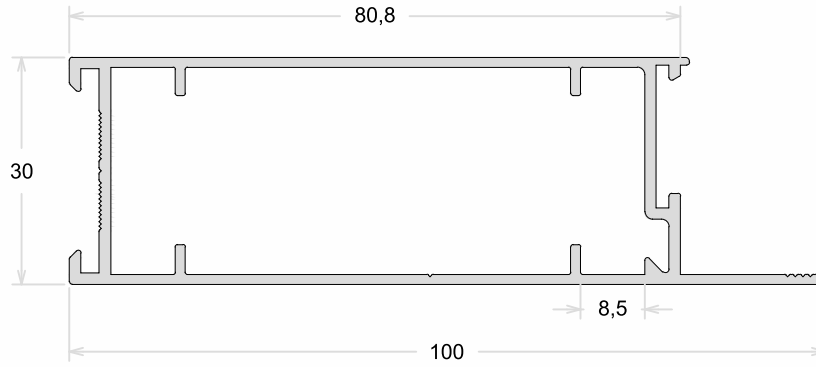

A-081	Folha Horizontal
Peso (Kg/m)	Perfis De Encaixe:
1,163	

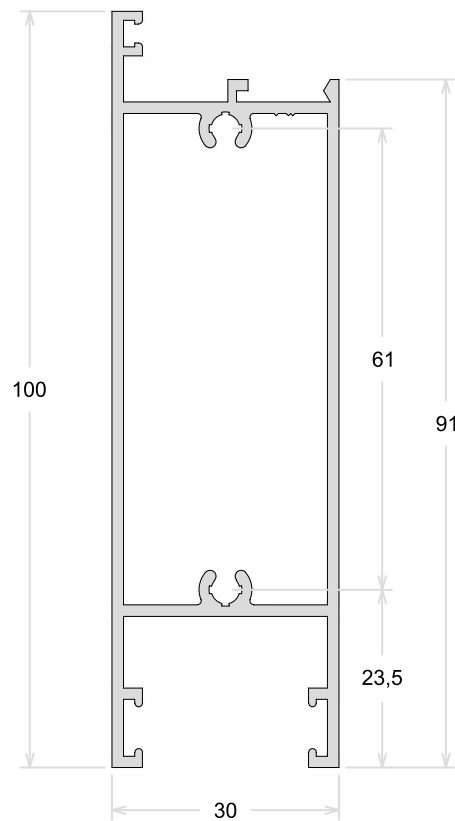

P-078	Travessa 56mm
Peso (Kg/m)	Perfis De Encaixe:
0,741	

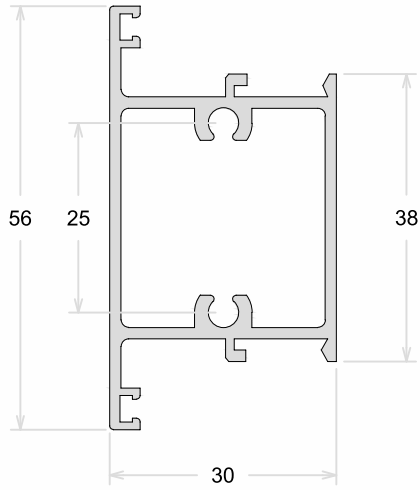

PPO-004	Travessa 75mm
Peso (Kg/m)	Perfis De Encaixe:
0,807	

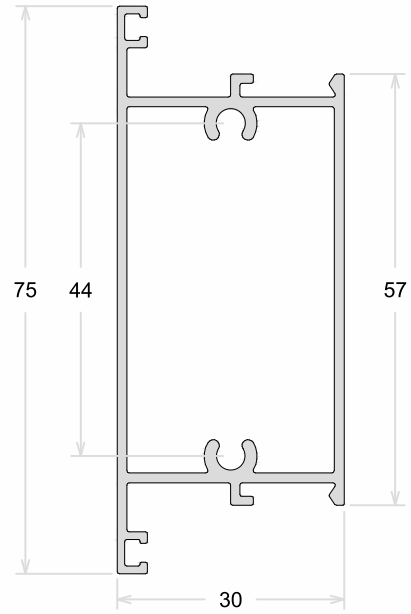

BG-001	Baguete Perimetral
Peso (Kg/m)	Perfis De Encaixe:
0,091	

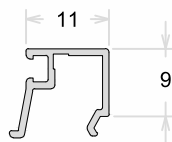

BG-013	Baguete Perimetral
Peso (Kg/m)	Perfis De Encaixe:
0,110	

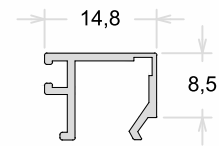

P-064	Folha - Maxim Ar / Fixo
Peso (Kg/m)	Perfis De Encaixe:
0,398	

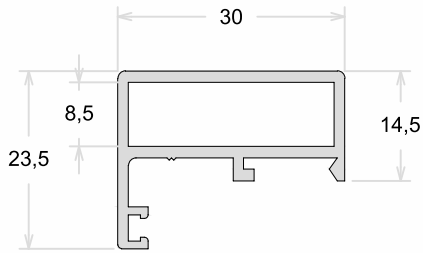

P-419	Coluna
Peso (Kg/m)	Perfis De Encaixe:
0,753	

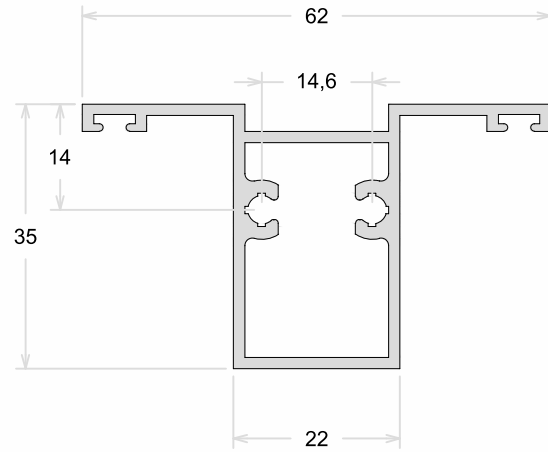

Y-148	Inversor
Peso (Kg/m)	Perfis De Encaixe:
0,330	

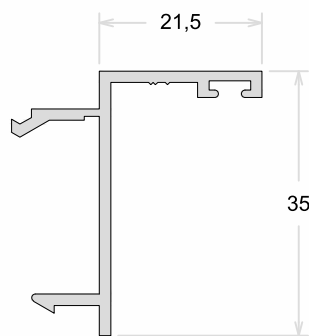

Y-350	Marco Bandeira / Peitoril
Peso (Kg/m)	Perfis De Encaixe:
1,046	

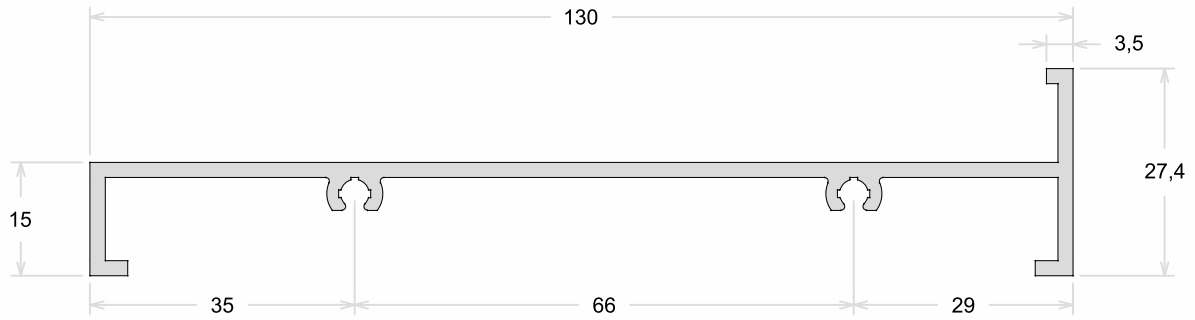

A-103	Folha Horizontal
Peso (Kg/m)	Perfis De Encaixe:
1,577	

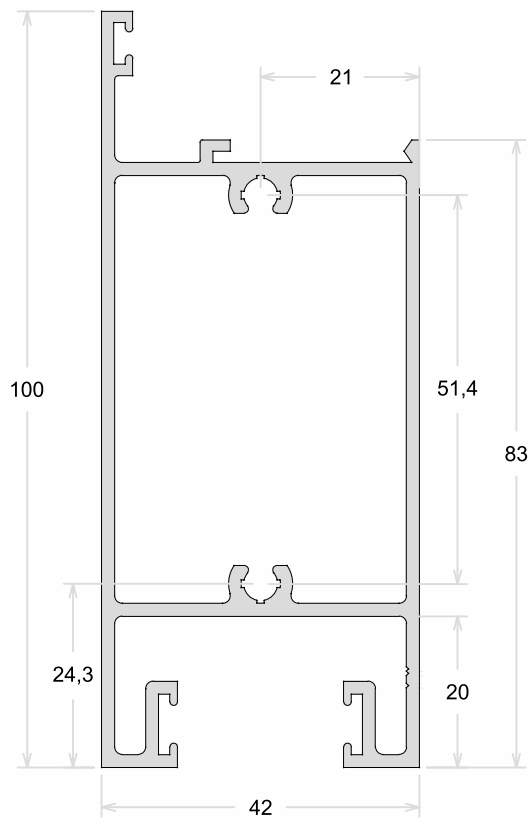

P-280	Marco Porta De Giro
Peso (Kg/m)	Perfis De Encaixe:
0,816	

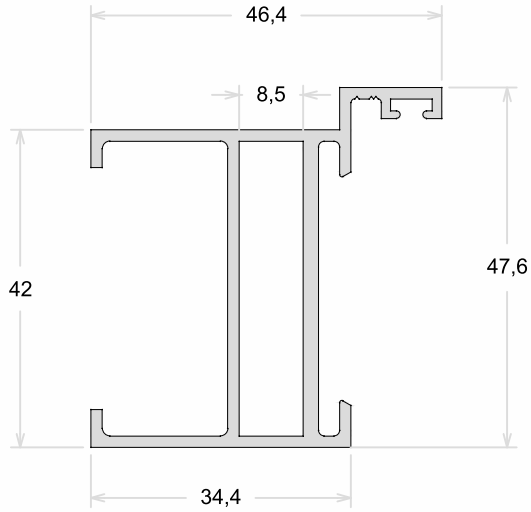

42-014	Batente Porta De Giro
Peso (Kg/m)	Perfis De Encaixe:
0,374	

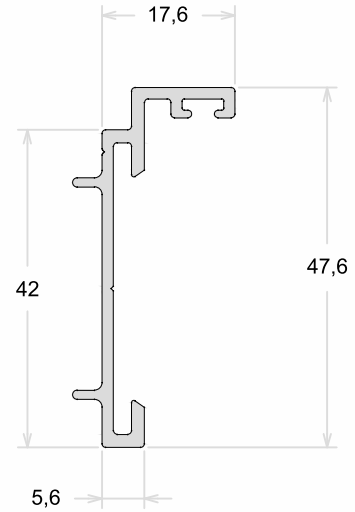

Y-271	Marco Fixo
Peso (Kg/m)	Perfis De Encaixe:
0,593	BG-037

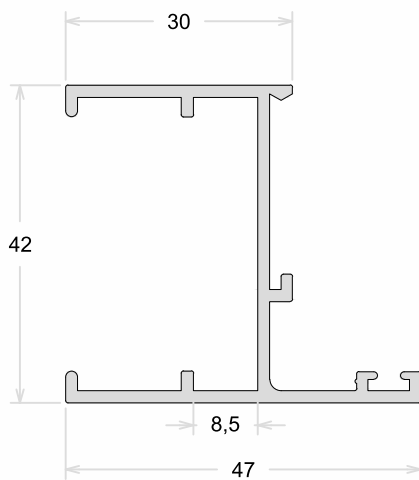

BG-037	Baguete Perimetral
Peso (Kg/m)	Perfis De Encaixe:
0,208	Y-271 / 42-035 / 42-032 / 42-007 / 42-061 / P-253

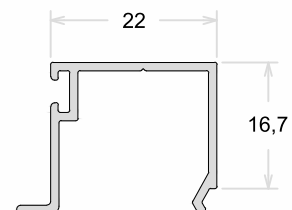

42-035	Folha Porta De Giro
Peso (Kg/m)	Perfis De Encaixe: BG-037
1,156	

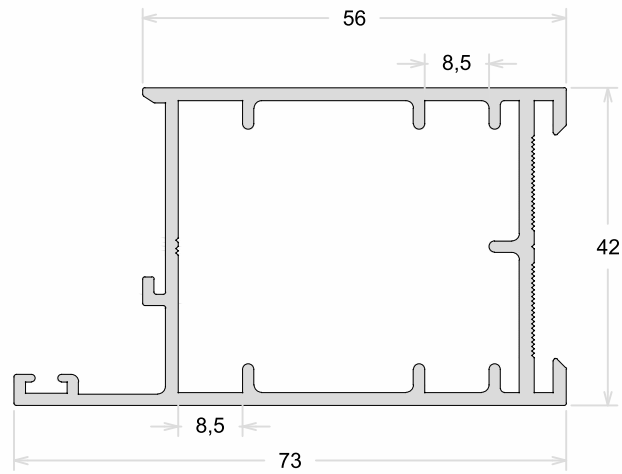

42-032	Folha Porta De Giro
Peso (Kg/m)	Perfis De Encaixe: BG-037
1,375	

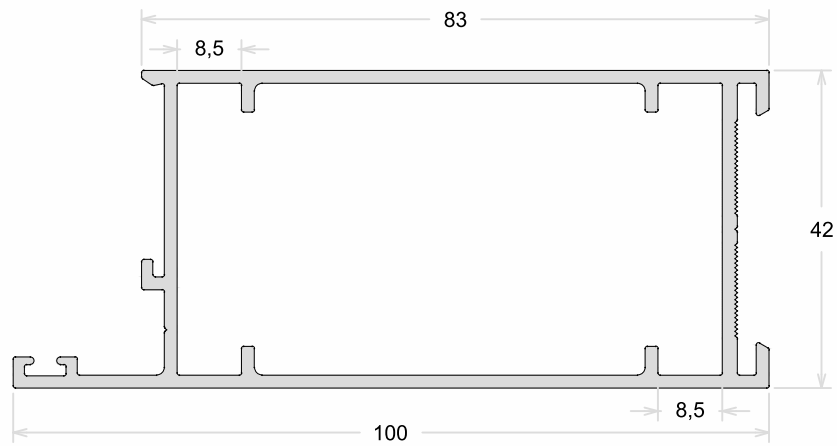

42-007	Travessa 100mm
Peso (Kg/m)	Perfis De Encaixe: BG-037
1,331	

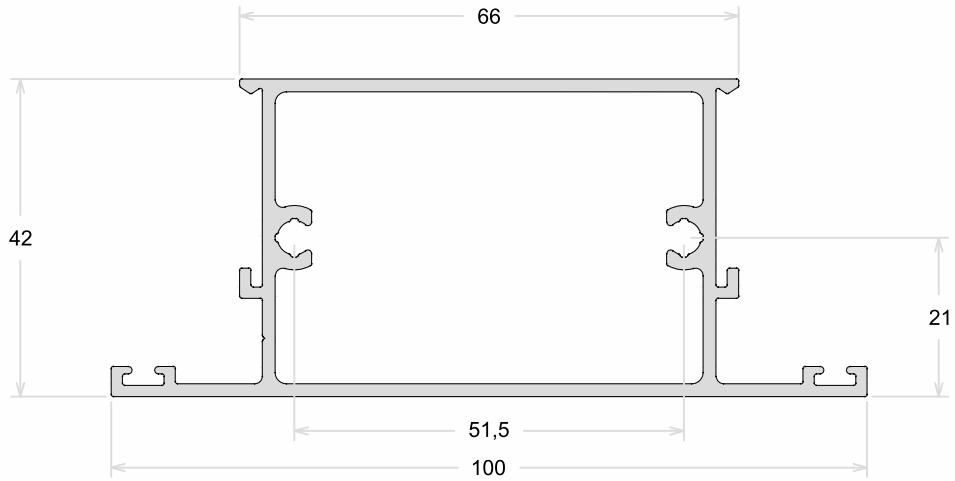

P-253	Quadro Fixo
Peso (Kg/m)	Perfis De Encaixe: BG-037
0,581	

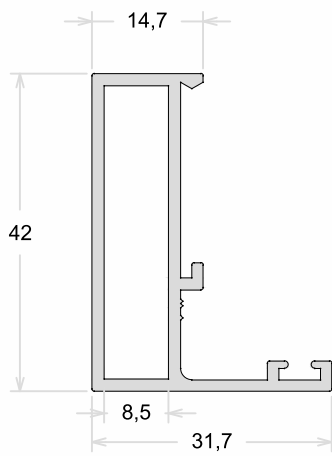

42-061	Folha Lateral
Peso (Kg/m)	Perfis De Encaixe: BG-037
1,135	

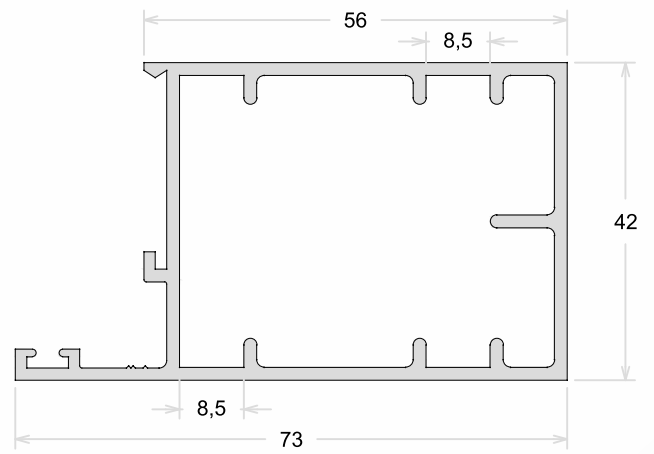

PPO-008	Marco Regulável L32
Peso (Kg/m)	Perfis De Encaixe:
1,031	

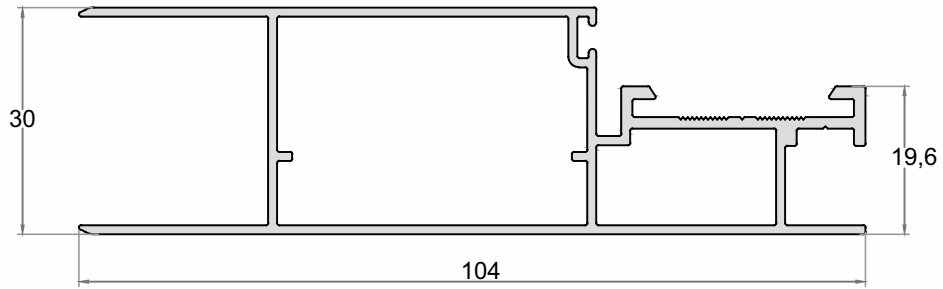

PPO-010	Vista Externa
Peso (Kg/m)	Perfis De Encaixe:
0,755	

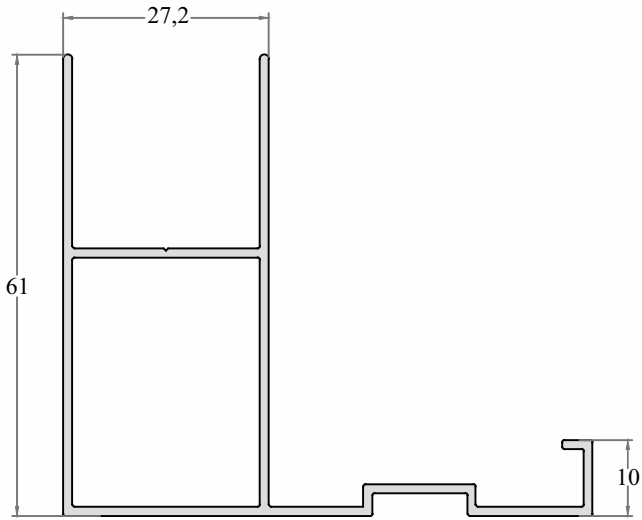

PPO-011	Prolongador do Marco
Peso (Kg/m)	Perfis De Encaixe:
0,381	

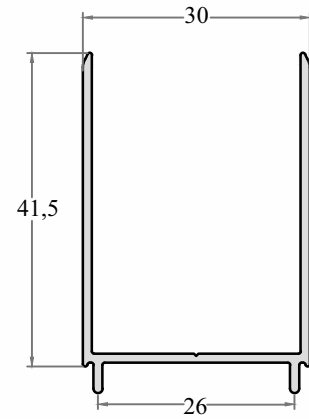

PPO-012	Vista Interna
Peso (Kg/m)	Perfis De Encaixe:
0,407	

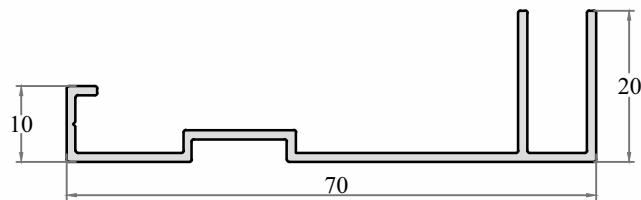

42-040	Batente Marco
Peso (Kg/m)	Perfis De Encaixe:
0,621	

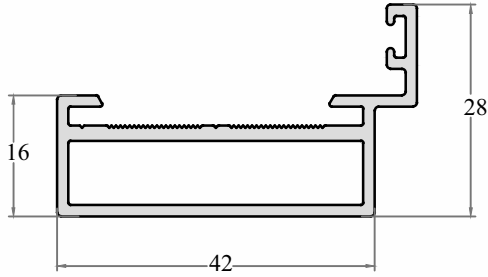

42-048	Click de Acabamento da Folha
Peso (Kg/m)	Perfis De Encaixe:
0,097	

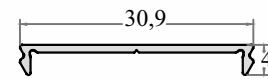

PEX-002	Arremate / Rodapé
Peso (Kg/m)	Perfis De Encaixe:
0,332	

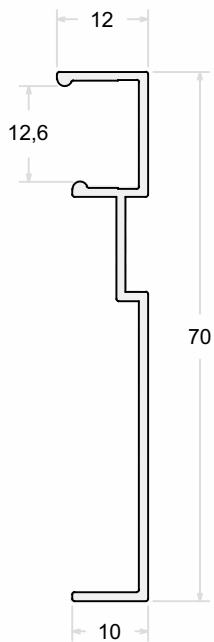

CM-063	Contramarco
Peso (Kg/m)	Perfis De Encaixe:
0,154	

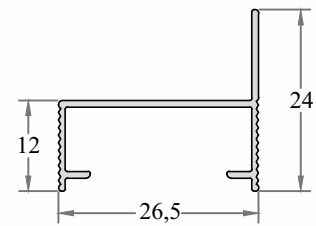

42-050	Folha da Porta
Peso (Kg/m)	Perfis De Encaixe:
2,052	

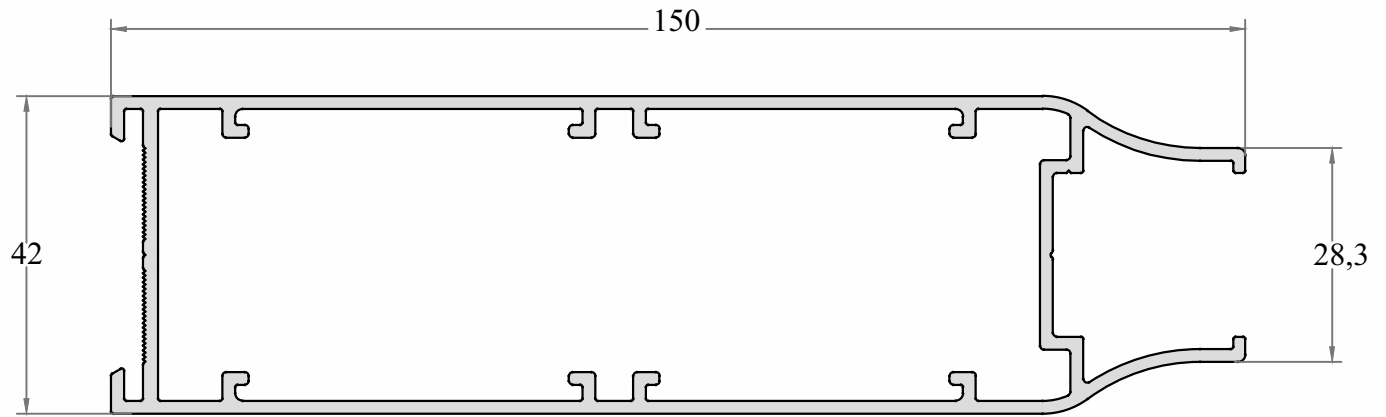

PLB-042	Lambri
Peso (Kg/m)	Perfis De Encaixe:
1,382	

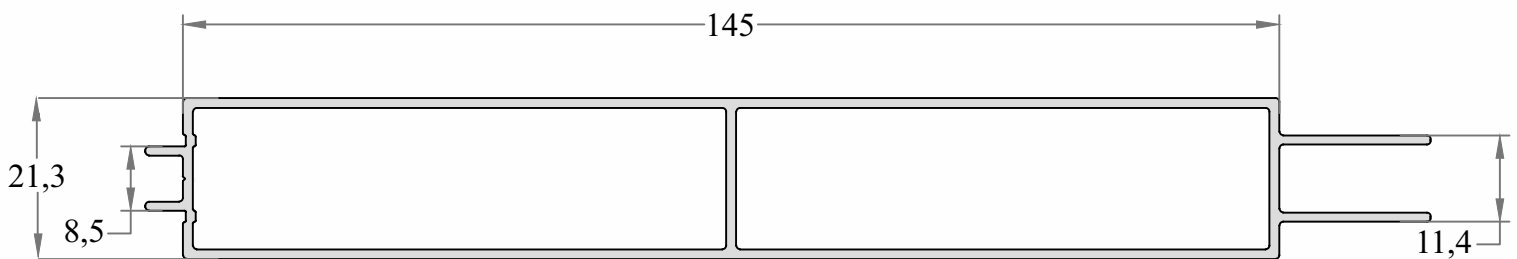

PLB-080	Lambri
Peso (Kg/m)	Perfis De Encaixe:
1,382	

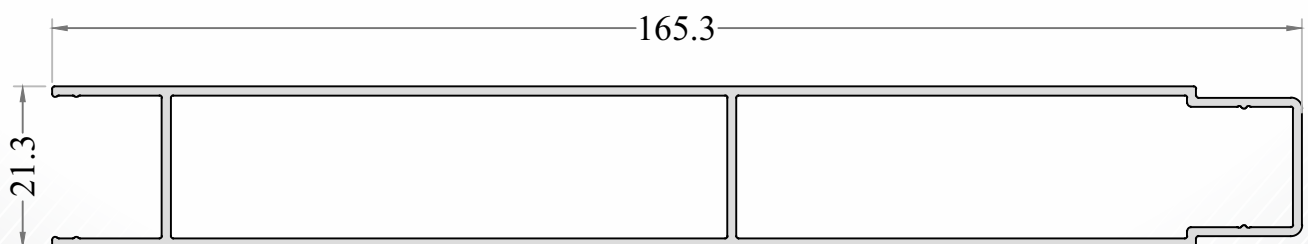

PEI-003 Trilho Superior

Peso (Kg/m) 0,777

Perfis De Encaixe: PEI-004

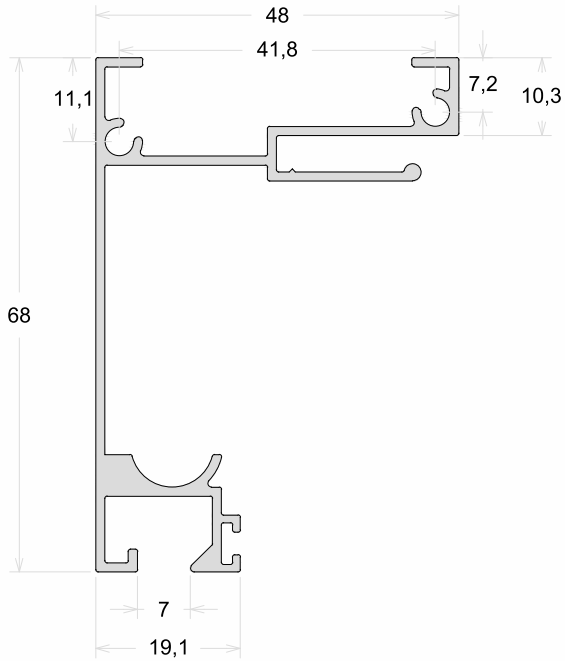

PEI-002 Marco Lateral

Peso (Kg/m) 0,432

Perfis De Encaixe:

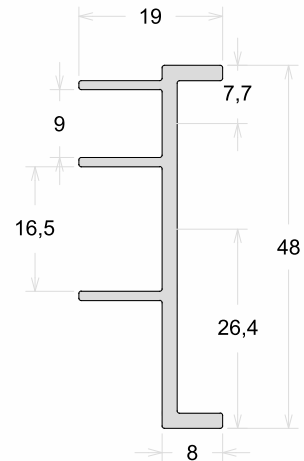

PEI-001 Trilho Inferior

Peso (Kg/m) 0,537

Perfis De Encaixe: PEI-004

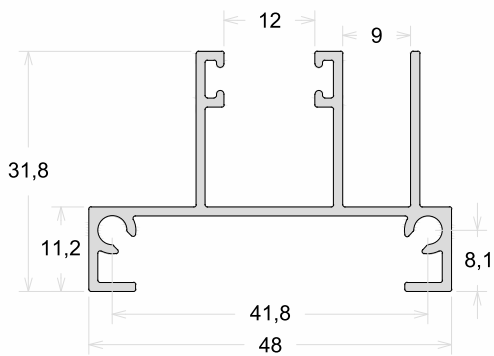

PEI-004 Click Do Trilho

Peso (Kg/m) 0,056

Perfis De Encaixe: PEI-001 / PEI-003

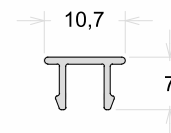

PEI-005	Arremate Vertical
Peso (Kg/m)	Perfis De Encaixe:
0,114	

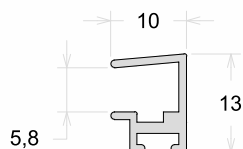

PEI-006	Arremate Central
Peso (Kg/m)	Perfis De Encaixe:
0,103	

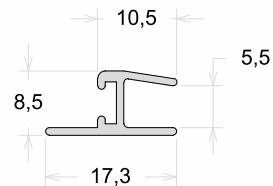

PAL-040	Trilho Superior
Peso (Kg/m)	Perfis De Encaixe: PAL-032
0,552	

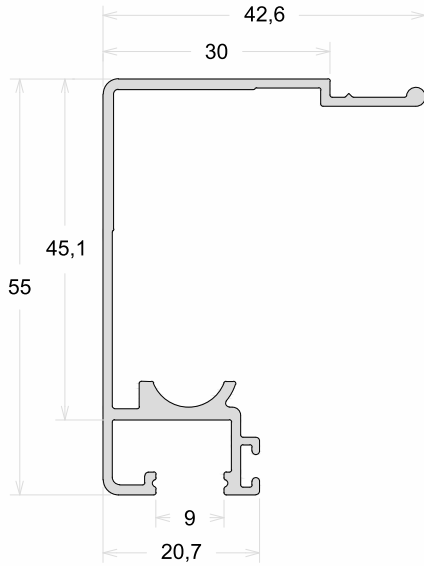

PAL-040L	Trilho Superior
Peso (Kg/m)	Perfis De Encaixe: PAL-032
0,449	

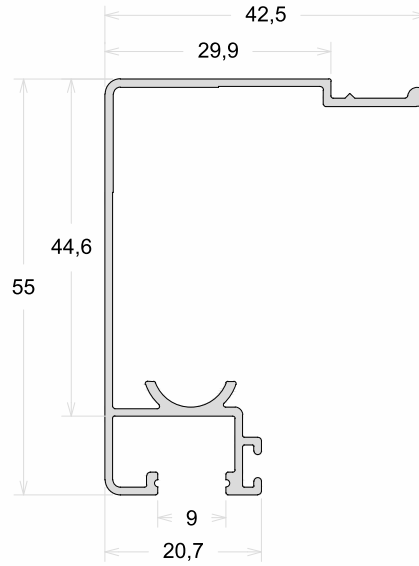

PAL-044	Trilho Superior
Peso (Kg/m)	Perfis De Encaixe: PAL-050 / PAL-050FT
0,522	

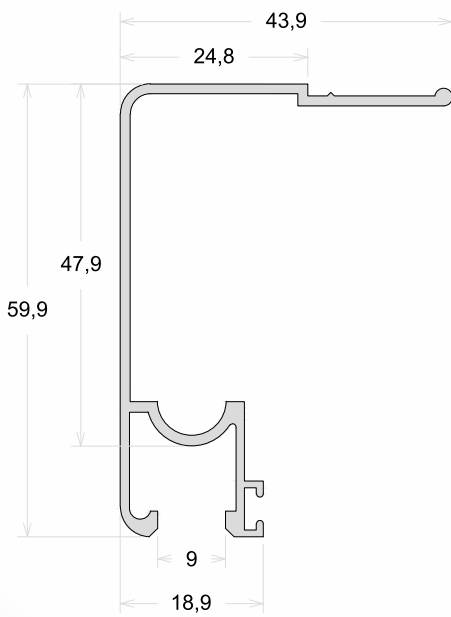

PAL-049	Trilho Superior
Peso (Kg/m)	Perfis De Encaixe: PAL-050 / PAL-050FT
0,550	

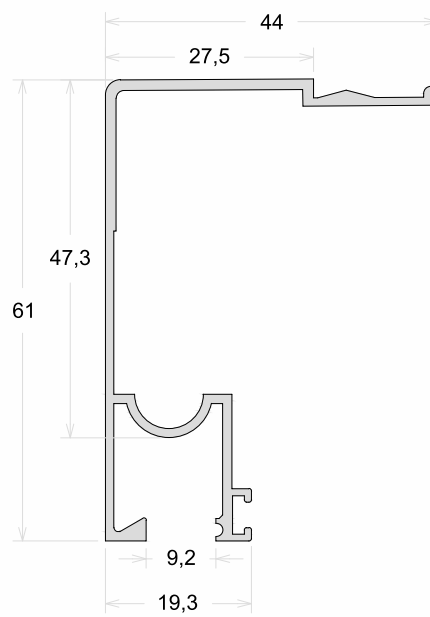

PAL-144	Trilho Superior
Peso (Kg/m)	Perfis De Encaixe: PAL-143
0,492	

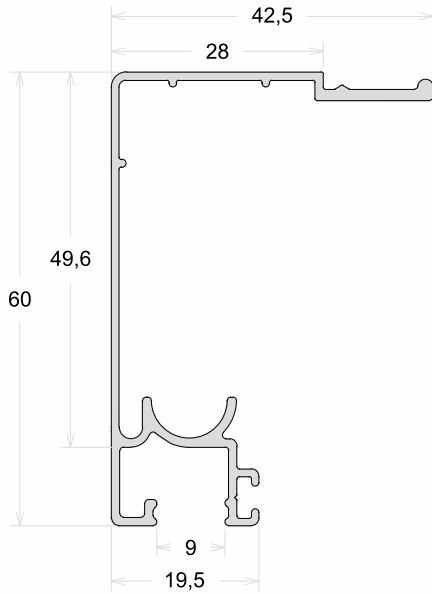

PAL-229	Trilho Superior
Peso (Kg/m)	Perfis De Encaixe: PAL-050 / PAL-050FT
0,684	

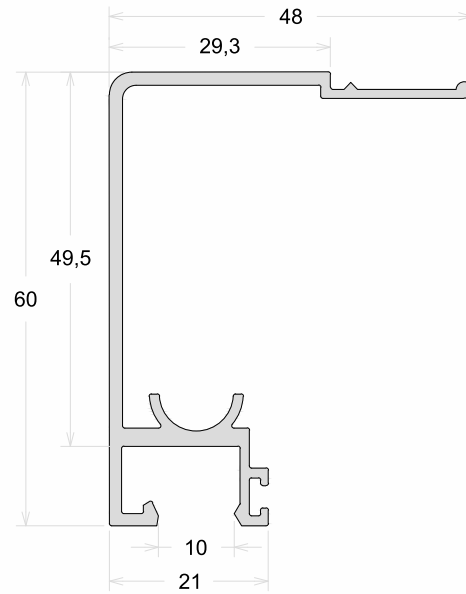

L-1049	Trilho Superior
Peso (Kg/m)	Perfis De Encaixe: E-1050
0,763	

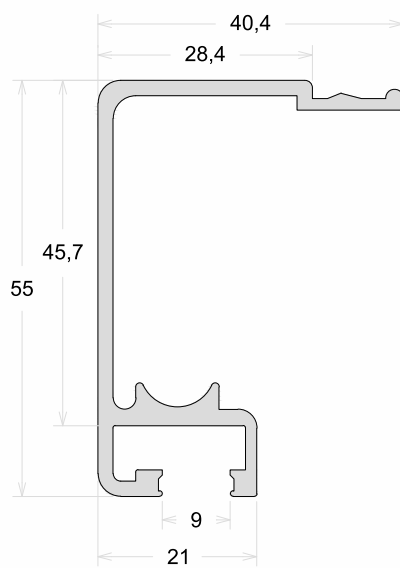

PAL-032	Capa Do Trilho Superior
Peso (Kg/m)	Perfis De Encaixe: PAL-040 / PAL-040L
0,239	

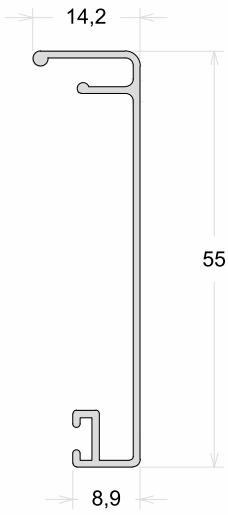

PAL-143	Capa Do Trilho Superior
Peso (Kg/m)	Perfis De Encaixe: PAL-144
0,287	

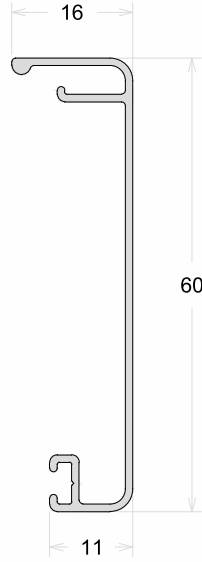

PAL-050	Capa Do Trilho Superior
Peso (Kg/m)	Perfis De Encaixe: PAL-044 / PAL-049 / PAL-229
0,239	

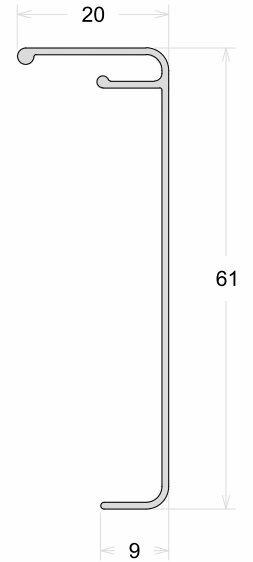

PAL-050FT	Capa Do Trilho Superior
Peso (Kg/m)	Perfis De Encaixe: PAL-044 / PAL-049 / PAL-229
0,272	

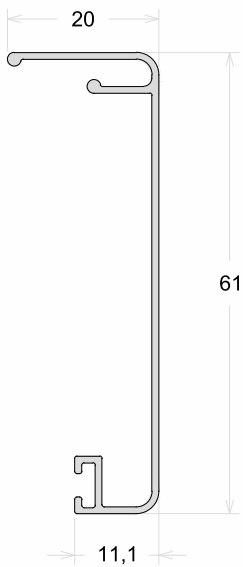

E-1050	Capa Do Trilho Superior
Peso (Kg/m)	Perfis De Encaixe: L-1049
0,240	

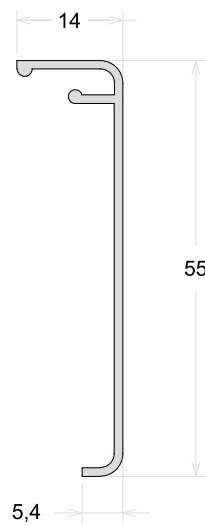

E-1052	Capa Do Trilho Superior
Peso (Kg/m)	Perfis De Encaixe:
0,279	

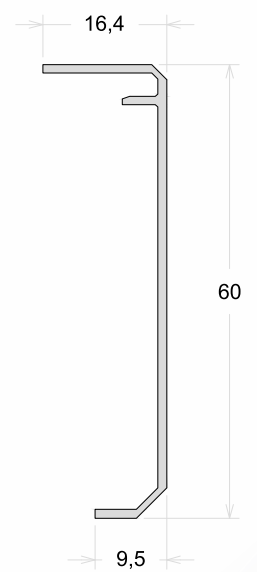

PAL-075	PAL-075L	Trilho Inferior
Peso (Kg/m)	Peso (Kg/m)	Perfis De Encaixe: PAL-043
0,320	0,262	

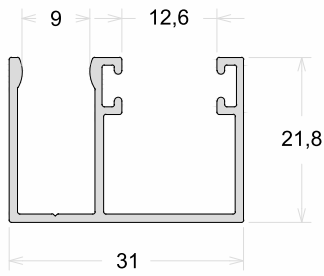

PAL-076	Trilho Inferior
Peso (Kg/m)	Perfis De Encaixe: BX-102 / PAL-043
0,294	

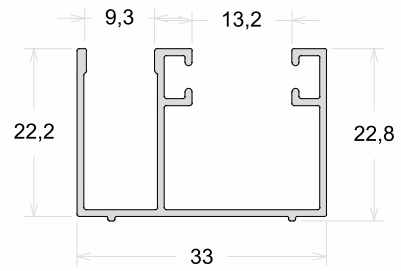

PAL-122	Trilho Inferior
Peso (Kg/m)	Perfis De Encaixe: PAL-168
0,363	

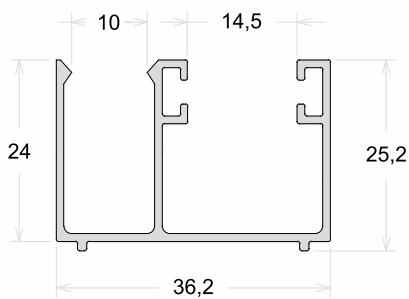

PAL-048	Travessa Peitoril
Peso (Kg/m)	Perfis De Encaixe: PAL-168
1,357	

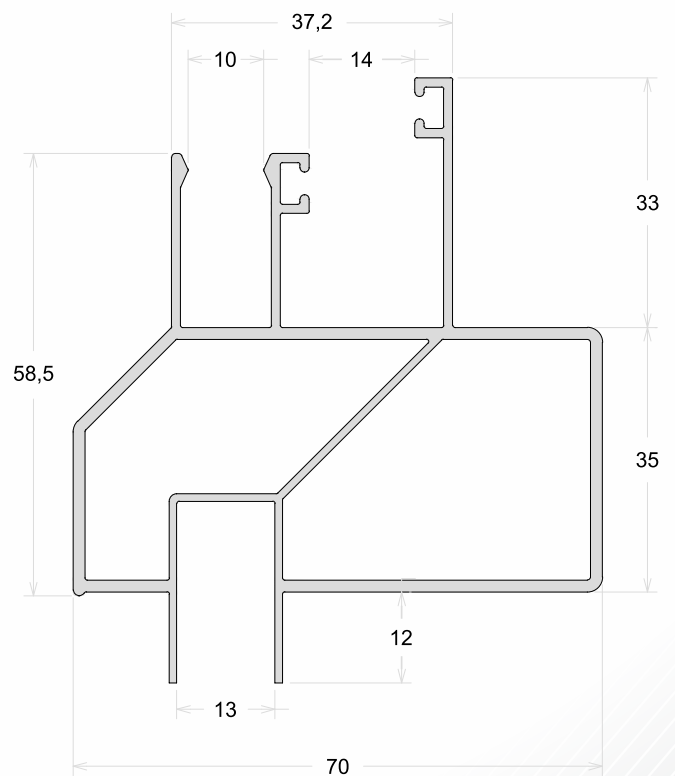

PAL-043	Click Do Trilho
Peso (Kg/m)	Perfis De Encaixe:
0,075	

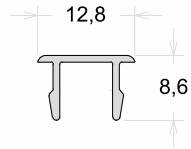

PAL-168	Click Do Trilho
Peso (Kg/m)	Perfis De Encaixe:
0,073	

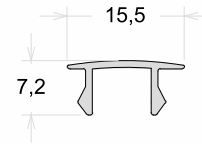

BX-102	Click Do Trilho
Peso (Kg/m)	Perfis De Encaixe:
0,050	

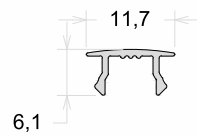

PAL-054	Arremate Lateral
Peso (Kg/m)	Perfis De Encaixe:
0,128	

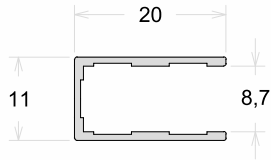

BX-063	PAL-540	Arremate Lateral
Peso (Kg/m)	Peso (Kg/m)	Perfis De Encaixe:
0,154	0,140	

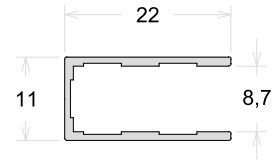

PAL-126	Arremate Vertical
Peso (Kg/m)	Perfis De Encaixe:
0,096	

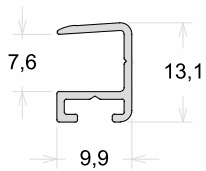

PAL-016	Arremate Vertical
Peso (Kg/m)	Perfis De Encaixe:
0,120	

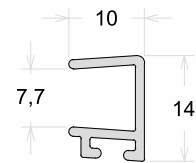

BX-056	Arremate Vertical
Peso (Kg/m)	Perfis De Encaixe:
0,160	

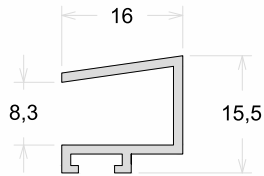

PAL-015	Arremate Vertical
Peso (Kg/m)	Perfis De Encaixe:
0,106	

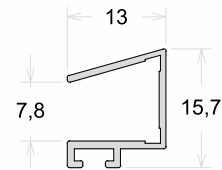

PAL-160	Arremate Vertical
Peso (Kg/m)	Perfis De Encaixe:
0,102	

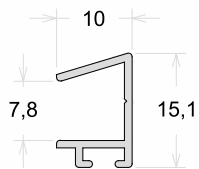

BX-128	Arremate Vertical
Peso (Kg/m)	Perfis De Encaixe:
0,128	

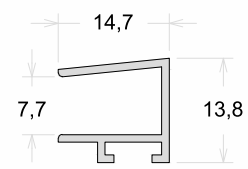

U-1015	Arremate Vertical
Peso (Kg/m)	Perfis De Encaixe:
0,197	

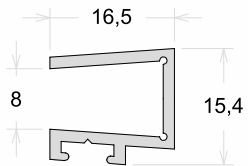

PAL-141	Arremate Vertical
Peso (Kg/m)	Perfis De Encaixe:
0,189	

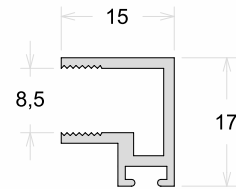

PAL-064	Arremate Central
Peso (Kg/m)	Perfis De Encaixe:
0,135	

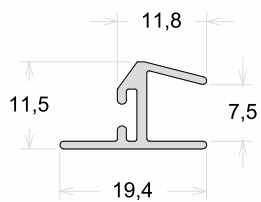

CL-063	Arremate Central
Peso (Kg/m)	Perfis De Encaixe:
0,163	

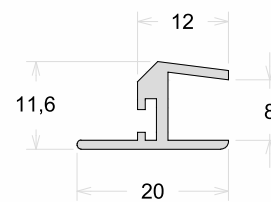

PAL-047	Arremate Central
Peso (Kg/m)	Perfis De Encaixe:
0,171	

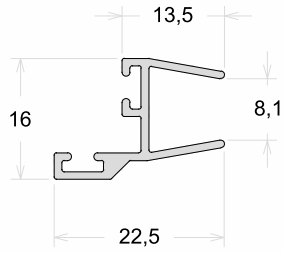

PAL-099	Arremate Central
Peso (Kg/m)	Perfis De Encaixe:
0,258	

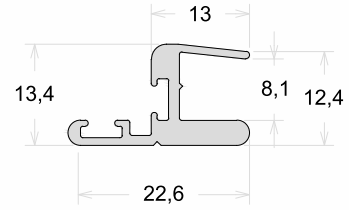

PAL-155	Arremate Central
Peso (Kg/m)	Perfis De Encaixe:
0,281	

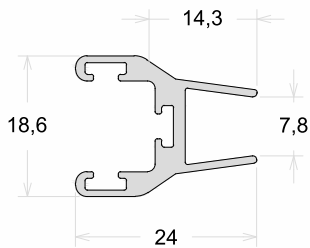

PAL-022	Arremate Perimetral
Peso (Kg/m)	Perfis De Encaixe:
0,130	

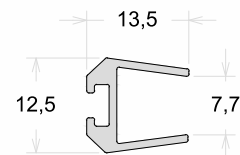

BX-252	Mão De Amigo
Peso (Kg/m)	Perfis De Encaixe:
0,202	

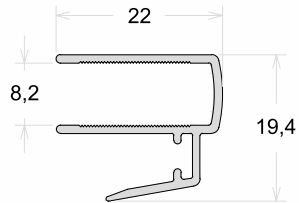

PAL-063	Arremate 90°
Peso (Kg/m)	Perfis De Encaixe:
0,150	

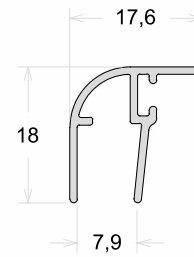

PAL-059	Cantoneira
Peso (Kg/m)	Perfis De Encaixe:
0,178	

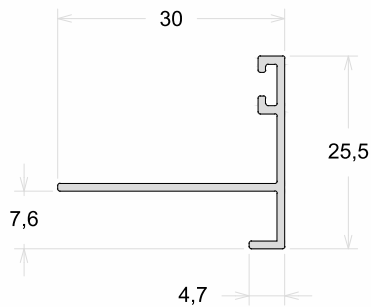

PAL-225	Cantoneira
Peso (Kg/m)	Perfis De Encaixe:
0,154	

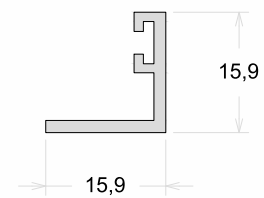

PAL-026	Quadro Fixo
Peso (Kg/m)	Perfis De Encaixe: PAL-027
0,245	

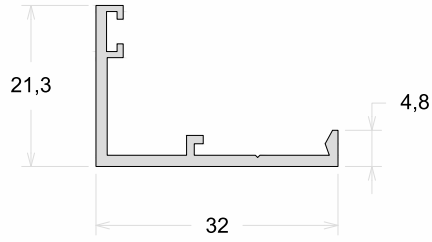

PAL-027	Baguete Do Quadro Fixo
Peso (Kg/m)	Perfis De Encaixe: PAL-026
0,161	

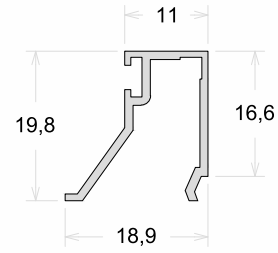

CX-125	Trilho Superior
Peso (Kg/m)	Perfis De Encaixe:
0,835	

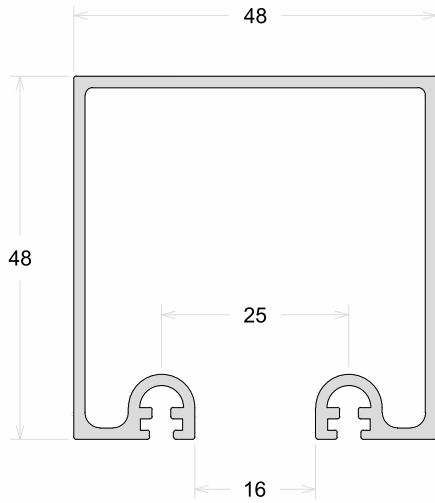

CX-124	Trilho Superior
Peso (Kg/m)	Perfis De Encaixe:
1,204	

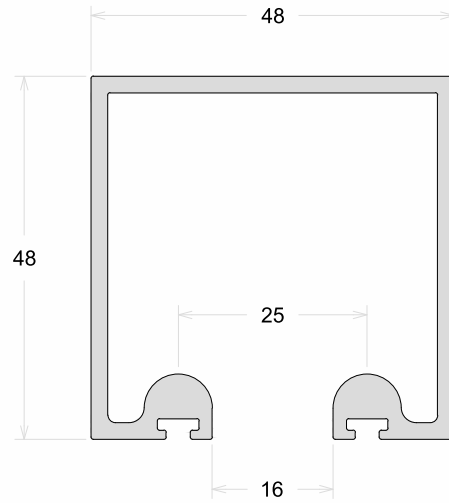

CX-126	Trilho Superior
Peso (Kg/m)	Perfis De Encaixe:
1,229	

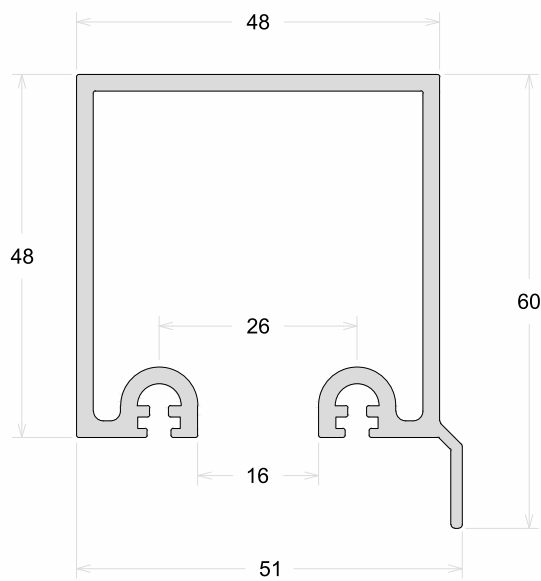

PAL-066	Trilho Inferior
Peso (Kg/m)	Perfis De Encaixe:
0,488	

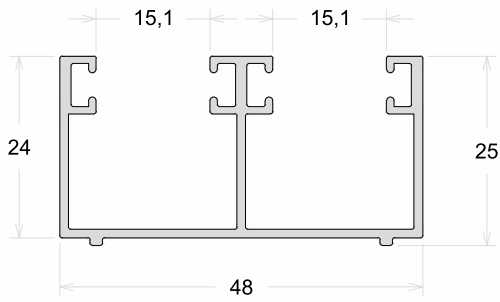

PAL-056	Trilho Inferior
Peso (Kg/m)	Perfis De Encaixe:
0,549	

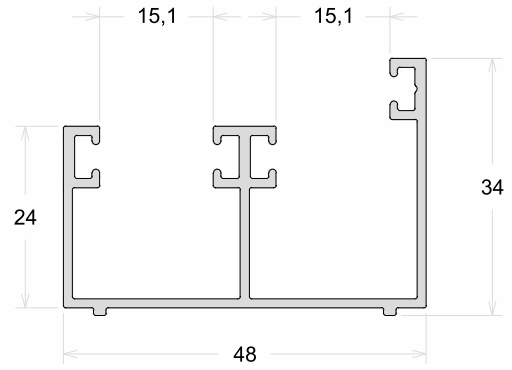

PAL-006	Trilho Inferior
Peso (Kg/m)	Perfis De Encaixe:
0,285	

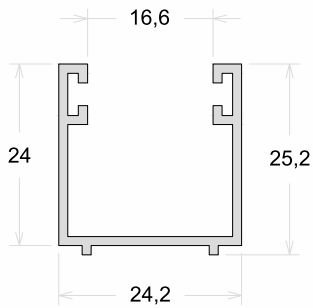

U-1108	Trilho Inferior
Peso (Kg/m)	Perfis De Encaixe:
0,365	

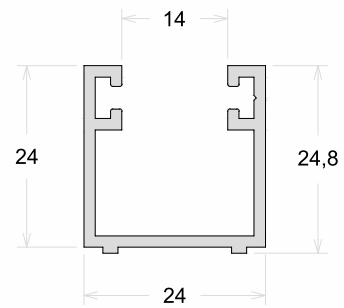

CX-248	Trilho Superior
Peso (Kg/m)	Perfis De Encaixe:
1,654	

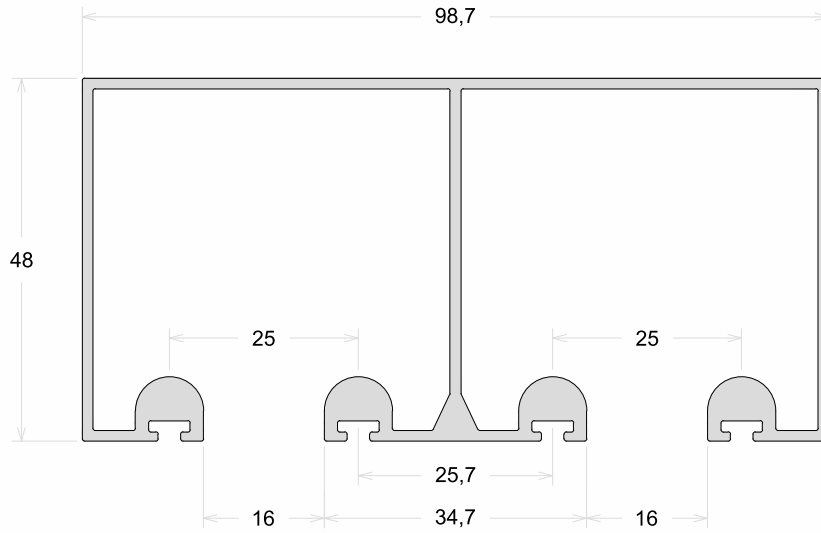

PAL-266	Trilho Inferior
Peso (Kg/m)	Perfis De Encaixe:
1,044	

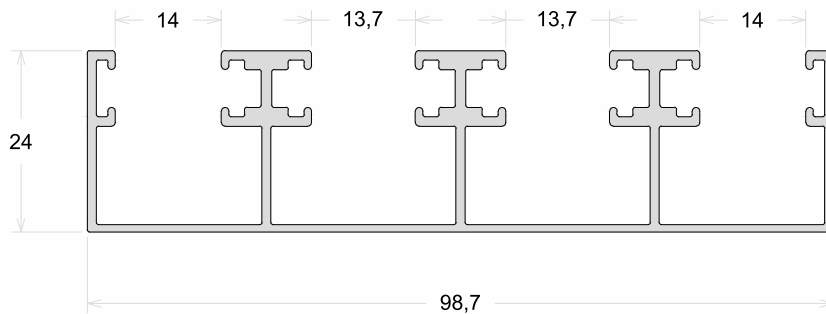

PAL-052	Trilho Superior
Peso (Kg/m)	Perfis De Encaixe: PAL-050 / PAL-050FT / PAL-013
0,627	

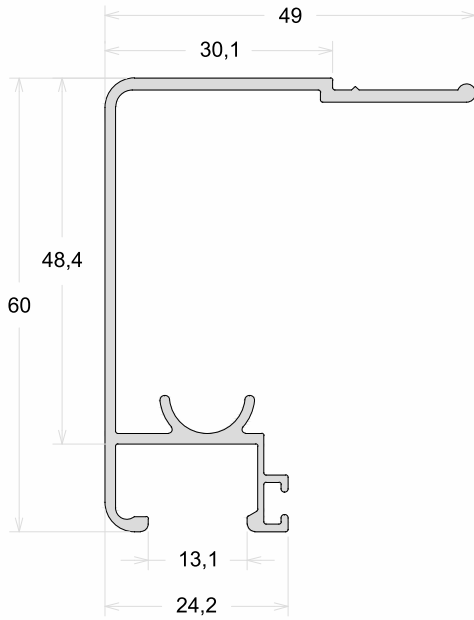

PAL-051	Trilho Superior
Peso (Kg/m)	Perfis De Encaixe: PAL-050 / PAL-050FT / PAL-013
0,659	

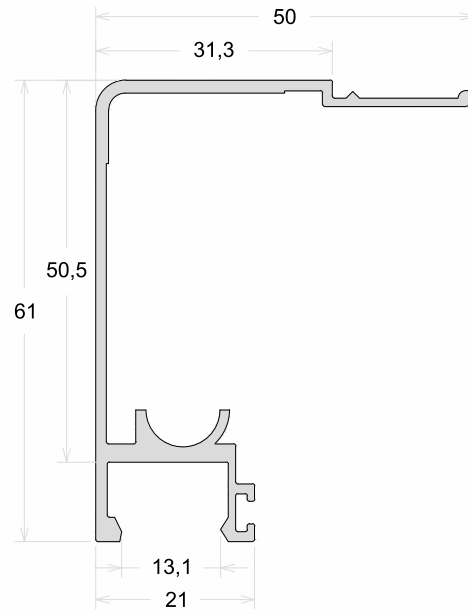

PAL-510	Trilho Superior
Peso (Kg/m)	Perfis De Encaixe: PAL-050 / PAL-050FT / PAL-013
0,743	

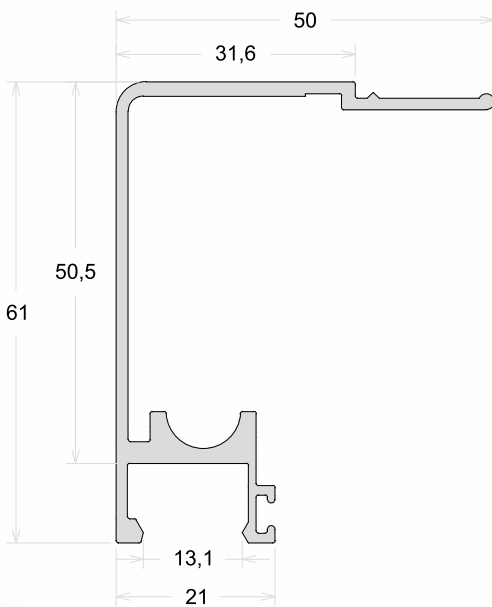

PAL-251	Trilho Superior
Peso (Kg/m)	Perfis De Encaixe: PAL-250 / PAL-013
0,674	

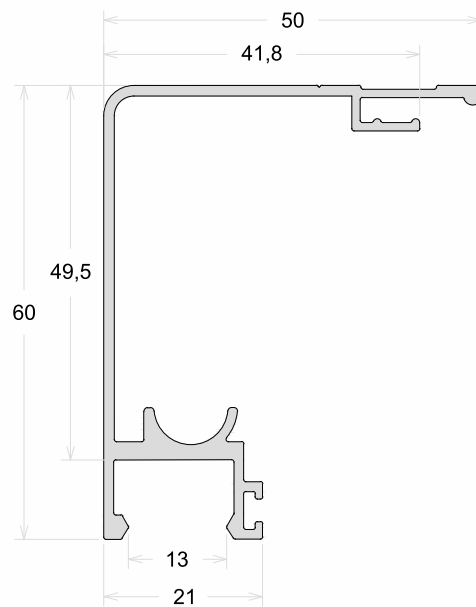

L-713	Trilho Superior
Peso (Kg/m)	Perfis De Encaixe: PAL-050 / PAL-050FT / PAL-013
1,265	E-512

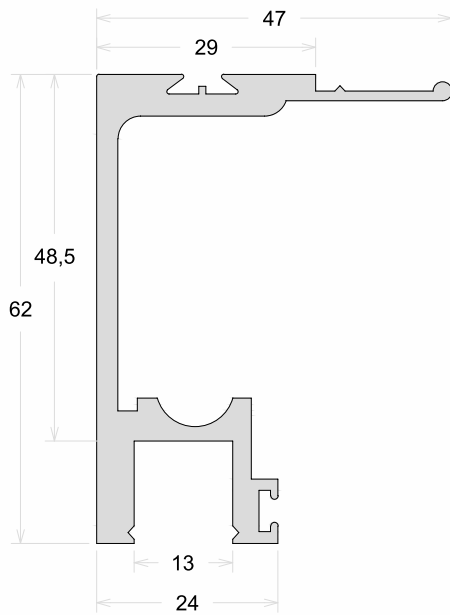

L-713L	Trilho Superior
Peso (Kg/m)	Perfis De Encaixe: PAL-050 / PAL-050FT / PAL-013
0,959	E-512

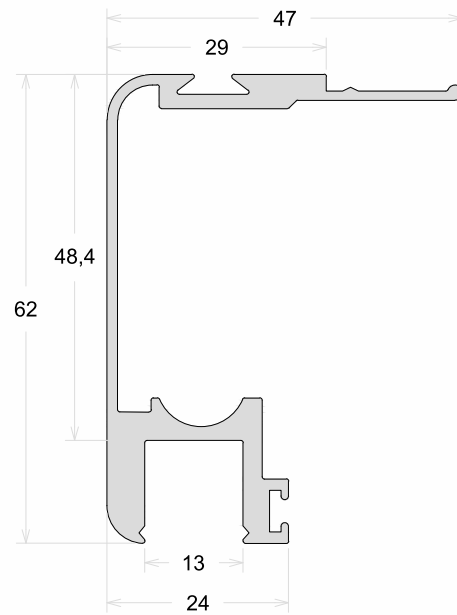

L-1051	Trilho Superior
Peso (Kg/m)	Perfis De Encaixe: PAL-050 / PAL-050FT / PAL-013
0,793	U-491

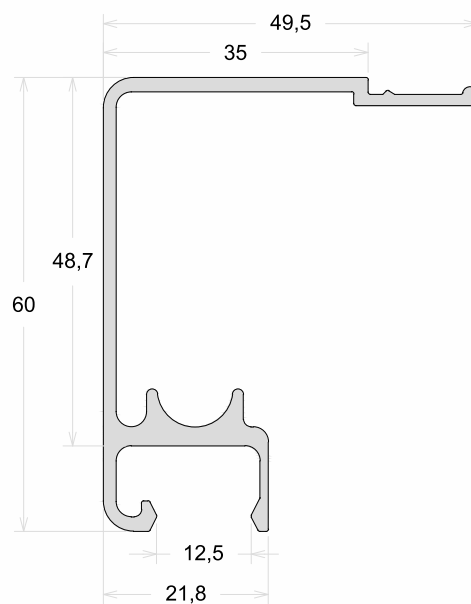

PAL-050	Capa Do Trilho Superior
Peso (Kg/m)	Perfis De Encaixe:
0,239	

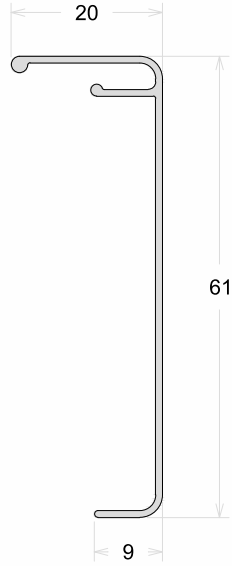

PAL-050 FT	Capa Do Trilho Superior
Peso (Kg/m)	Perfis De Encaixe:
0,272	

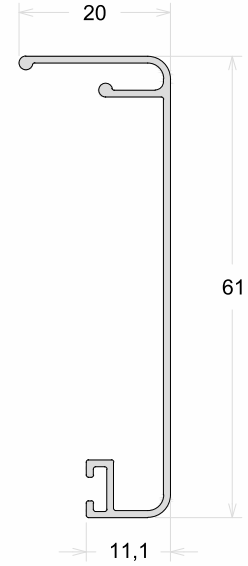

PAL-250	Capa Do Trilho Superior
Peso (Kg/m)	Perfis De Encaixe:
0,252	

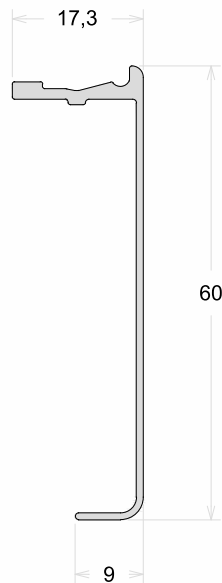

PAL-005	PAL-005L	Trilho Inferior
Peso (Kg/m)	Peso (Kg/m)	Perfis De Encaixe:
0,406	0,330	

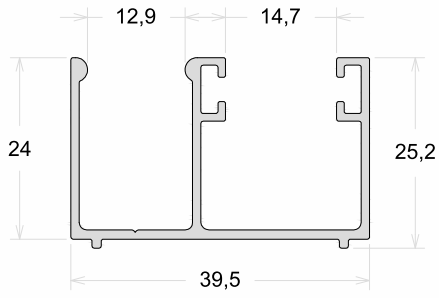

E-306L	Trilho Inferior
Peso (Kg/m)	Perfis De Encaixe:
0,356	

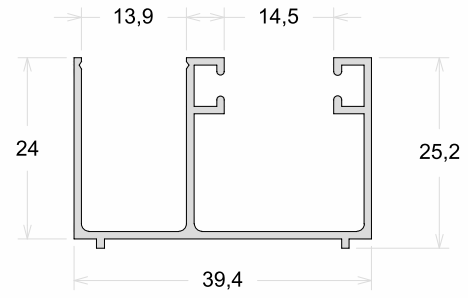

PAL-055	Trilho Inferior
Peso (Kg/m)	Perfis De Encaixe:
0,409	

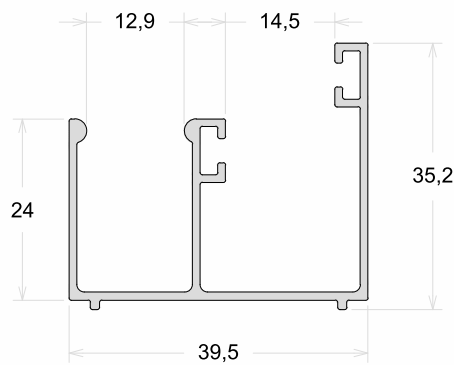

PAL-013	Click Do Trilho
Peso (Kg/m)	Perfis De Encaixe:
0,074	

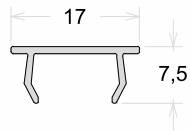

U-491	Click Do Trilho
Peso (Kg/m)	Perfis De Encaixe:
0,099	

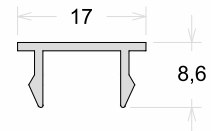

PAL-067	Arremate Lateral
Peso (Kg/m)	Perfis De Encaixe:
0,143	



BX-064	Arremate Lateral
Peso (Kg/m)	Perfis De Encaixe:
0,162	

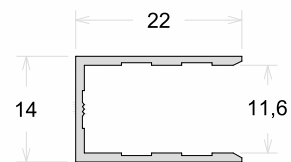

PAL-010	PAL-010L	Arremate Lateral
Peso (Kg/m)	Peso (Kg/m)	Perfis De Encaixe:
0,196	0,157	

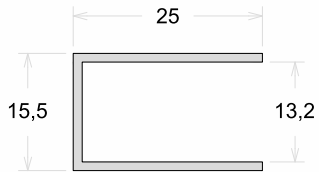

PAL-011	Arremate Lateral
Peso (Kg/m)	Perfis De Encaixe:
0,188	

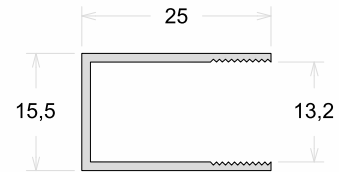

PAL-025	Arremate Lateral
Peso (Kg/m)	Perfis De Encaixe:
0,409	



PAL-024	Arremate Lateral
Peso (Kg/m)	Perfis De Encaixe:
0,527	

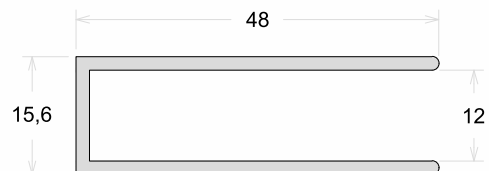

PAL-140	Arremate Vertical
Peso (Kg/m)	Perfis De Encaixe:
0,175	

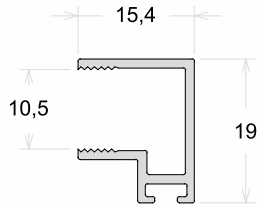

U-1014	PAL-014	Arremate Vertical
Peso (Kg/m)	Peso (Kg/m)	Perfis De Encaixe:
0,256	0,237	

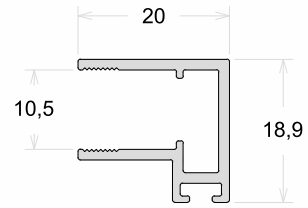

PAL-035	Arremate Lateral
Peso (Kg/m)	Perfis De Encaixe:
0,204	

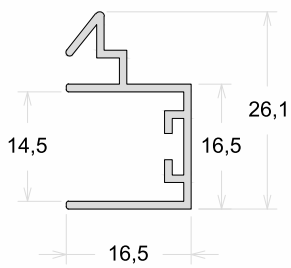

PAL-142	Vedação Inferior
Peso (Kg/m)	Perfis De Encaixe:
0,129	

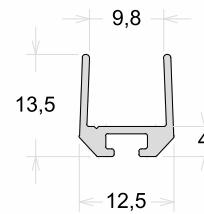

BX-131	Arremate Central
Peso (Kg/m)	Perfis De Encaixe:
0,135	

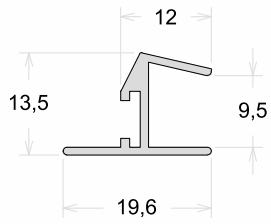

PAL-017	Arremate Central
Peso (Kg/m)	Perfis De Encaixe:
0,293	

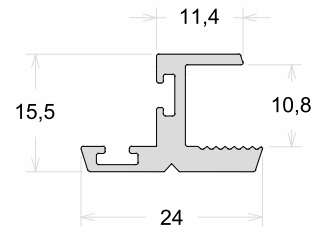

PAL-019	Arremate Central
Peso (Kg/m)	Perfis De Encaixe:
0,220	

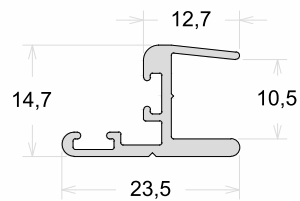

DV-020	Base Externa
Peso (Kg/m)	Perfis De Encaixe:
0,457	

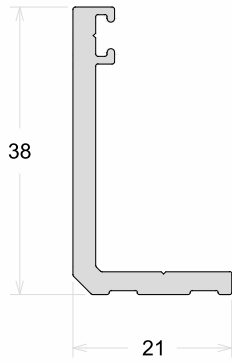

DV-021	Base Interna
Peso (Kg/m)	Perfis De Encaixe:
0,465	

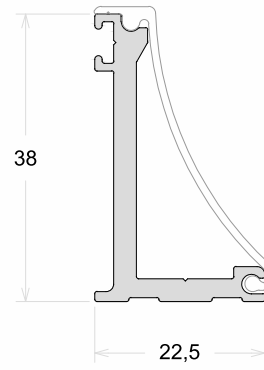

DV-022	Arremate Interno
Peso (Kg/m)	Perfis De Encaixe: DV-021
0,159	

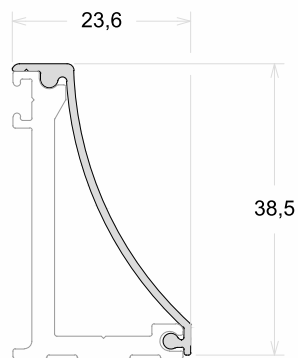

BX-253	Mão De Amigo
Peso (Kg/m)	Perfis De Encaixe:
0,208	

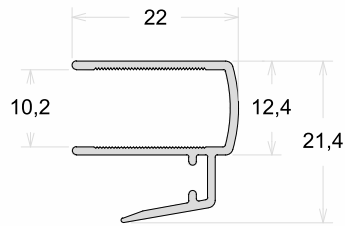

BX-250	Mão De Amigo
Peso (Kg/m)	Perfis De Encaixe:
0,289	

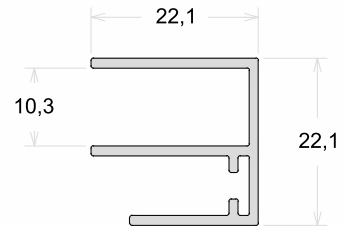

PAL-007	Trilho Inferior
Peso (Kg/m)	Perfis De Encaixe:
0,576	

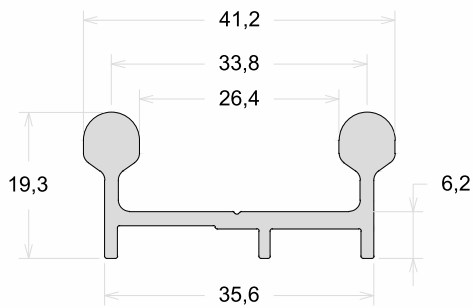

PAL-008	Trilho Inferior
Peso (Kg/m)	Perfis De Encaixe:
0,967	

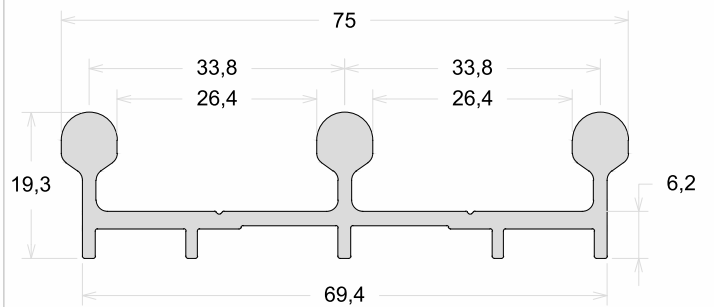

KIT-001	Trilho Superior
Peso (Kg/m)	Perfis De Encaixe: KIT-002 / KIT-003
0,516	

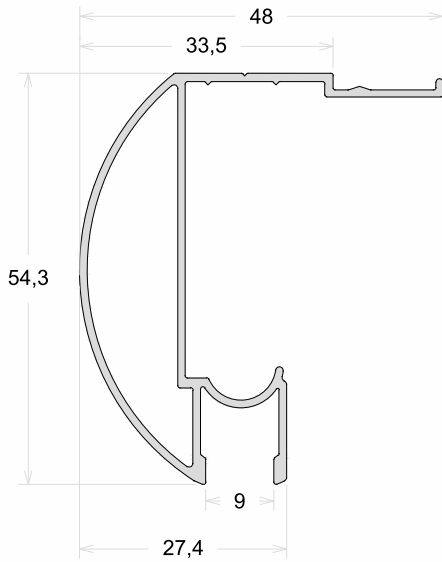

PAL-060	Trilho Superior
Peso (Kg/m)	Perfis De Encaixe: PAL-020 / PAL-021 / PAL-043
0,546	

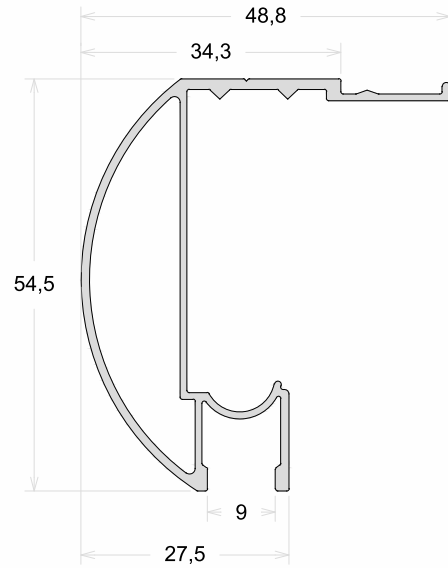

CL-058	Trilho Superior
Peso (Kg/m)	Perfis De Encaixe: CX-490
0,827	

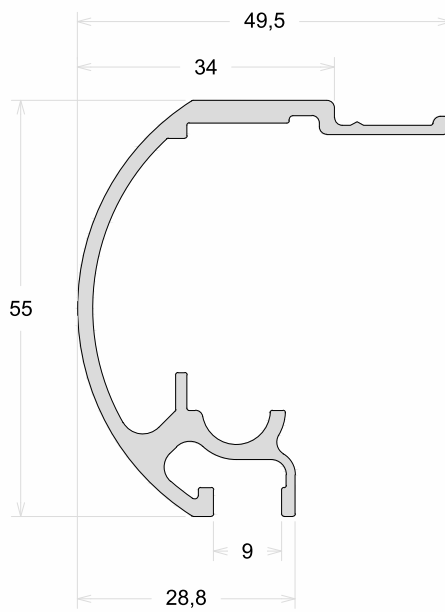

KIT-002	Capa Do Trilho Superior
Peso (Kg/m)	Perfis De Encaixe: KIT-001
0,193	

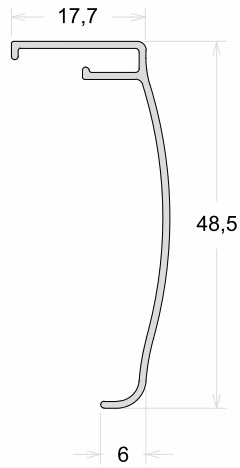

PAL-020	Capa Do Trilho Superior
Peso (Kg/m)	Perfis De Encaixe: PAL-060
0,229	

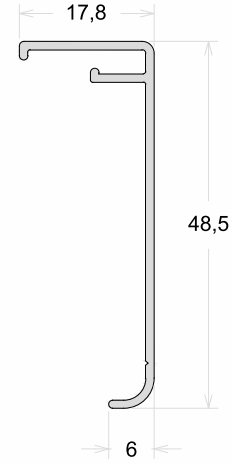

CX-490	Capa Do Trilho Superior
Peso (Kg/m)	Perfis De Encaixe: CL-058
0,219	

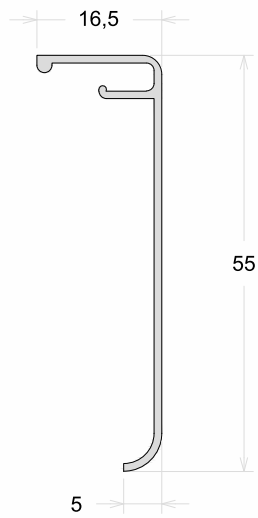

PAL-021	Capa Do Trilho Superior
Peso (Kg/m)	Perfis De Encaixe: PAL-060
0,228	

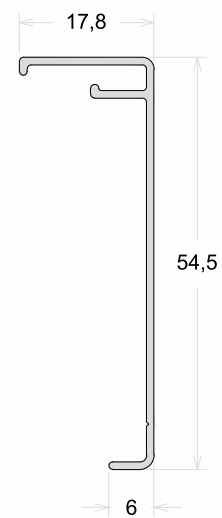

PAL-062	Trilho Inferior
Peso (Kg/m)	Perfis De Encaixe: PAL-043 / KIT-003
0,220	

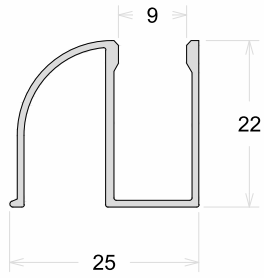

PAL-061	Trilho Inferior
Peso (Kg/m)	Perfis De Encaixe: PAL-043 / KIT-003
0,261	

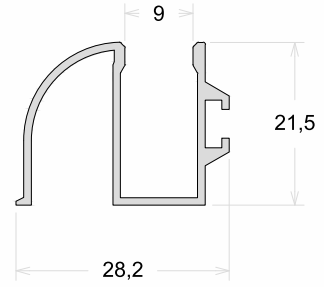

KIT-003	Click Do Trilho
Peso (Kg/m)	Perfis De Encaixe: KIT-001 / PAL-062 / PAL-061
0,069	

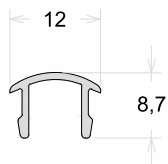

PAL-043	Click Do Trilho
Peso (Kg/m)	Perfis De Encaixe: PAL-060 / PAL-061 / PAL-062
0,075	

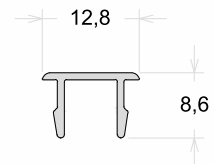

BX-230	Trilho Superior Quadrado
Peso (Kg/m)	Perfis De Encaixe: BX-102 / BX-232
0,524	

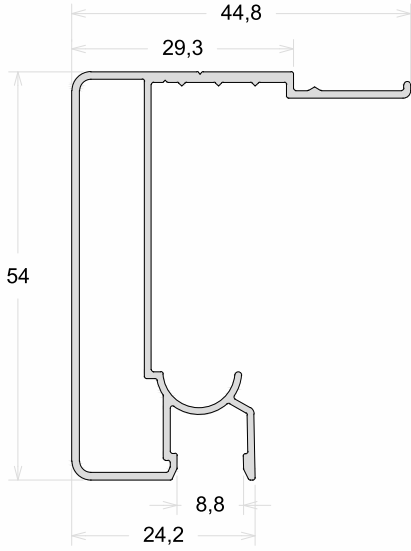

BX-232	Capa Do Trilho Superior
Peso (Kg/m)	Perfis De Encaixe: BX-230
0,189	

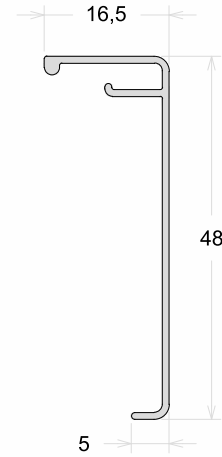

BX-233	Trilho Inferior
Peso (Kg/m)	Perfis De Encaixe: BX-102
0,244	

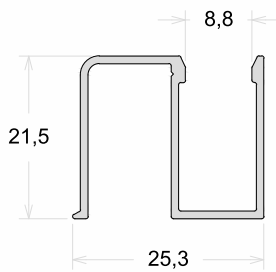

BX-234	Trilho Inferior
Peso (Kg/m)	Perfis De Encaixe: BX-102
0,276	

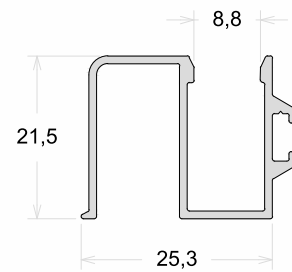

BX-102 Click Do Trilho

Peso (Kg/m): 0,050

Perfis De Encaixe: BX-230 / BX-233 / BX-234

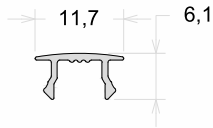

PAL-054 Arremate Lateral

Peso (Kg/m): 0,128

Perfis De Encaixe:

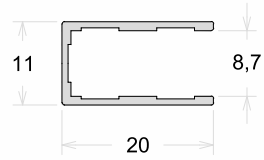

PAL-067 Arremate Lateral

Peso (Kg/m): 0,143

Perfis De Encaixe:

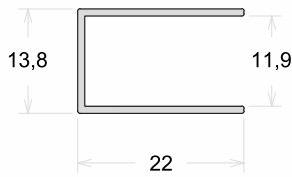

PAL-010 **PAL-010L** Arremate Lateral

Peso (Kg/m): 0,196

Peso (Kg/m): 0,157

Perfis De Encaixe:

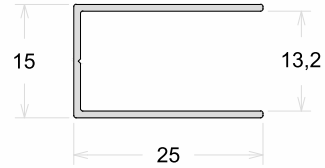

PAL-063 Arremate 90°

Peso (Kg/m): 0,150

Perfis De Encaixe:

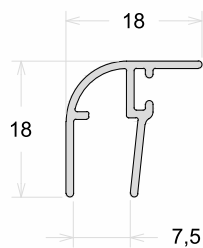

PAL-065 Batente Box De Giro

Peso (Kg/m): 0,214

Perfis De Encaixe:

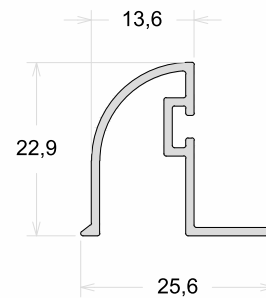

BX-055	Trilho Superior
Peso (Kg/m)	Perfis De Encaixe:
0,437	

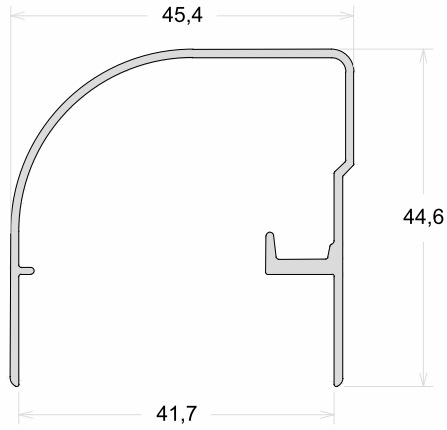

BX-010	Montante Lateral
Peso (Kg/m)	Perfis De Encaixe:
0,225	

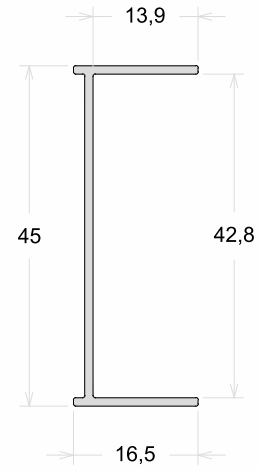

BX-053	Trilho Inferior
Peso (Kg/m)	Perfis De Encaixe:
0,205	

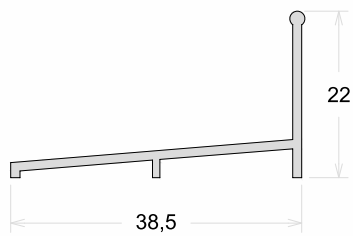

BX-051	Montante Lateral
Peso (Kg/m)	Perfis De Encaixe:
0,170	

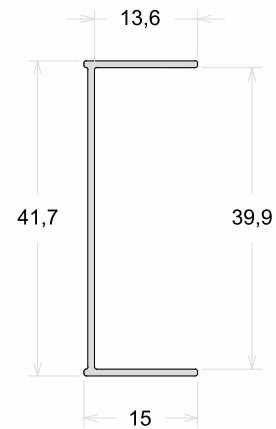

U-399	Montante Lateral
Peso (Kg/m)	Perfis De Encaixe:
0,274	

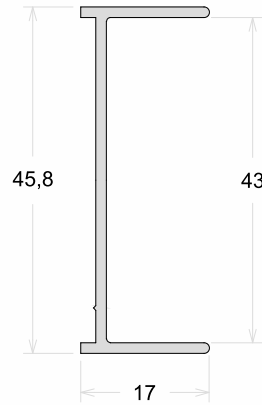

BX-052	Folha
Peso (Kg/m)	Perfis De Encaixe:
0,164	

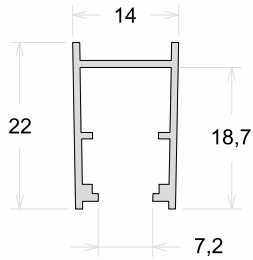

U-396	Folha
Peso (Kg/m)	Perfis De Encaixe:
0,176	

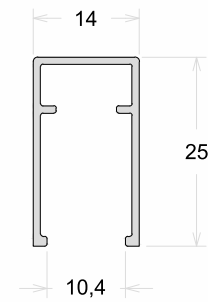

BX-054	Travessa Horizontal
Peso (Kg/m)	Perfis De Encaixe:
0,223	

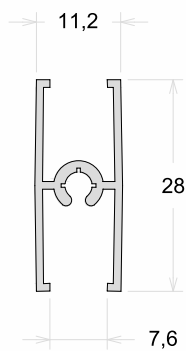

BX-006	Arremate Vertical
Peso (Kg/m)	Perfis De Encaixe:
0,232	

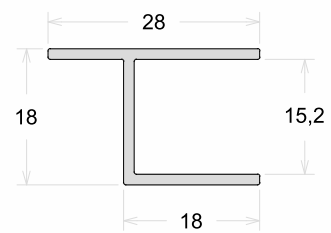

BX-005	Trilho Superior
Peso (Kg/m)	Perfis De Encaixe:
0,429	

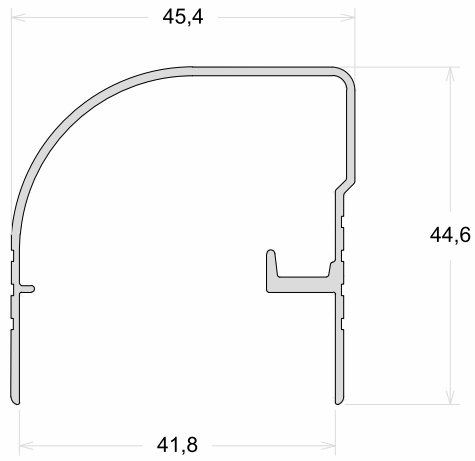

BX-140	Trilho Superior
Peso (Kg/m)	Perfis De Encaixe:
0,482	

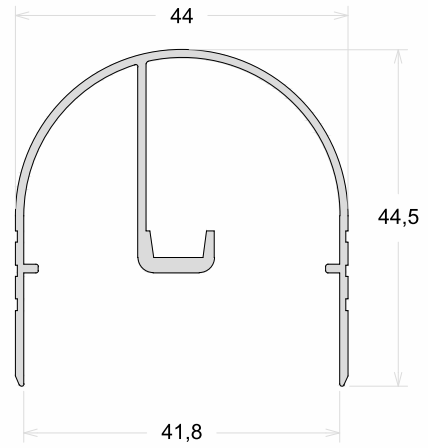

BX-091	Trilho Inferior
Peso (Kg/m)	Perfis De Encaixe:
0,157	

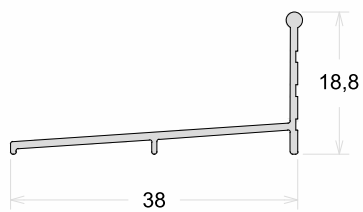

BX-003	Trilho Inferior
Peso (Kg/m)	Perfis De Encaixe:
0,215	

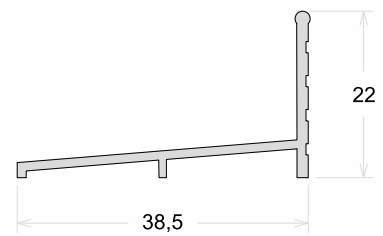

BX-001	Montante Lateral
Peso (Kg/m)	Perfis De Encaixe:
0,154	

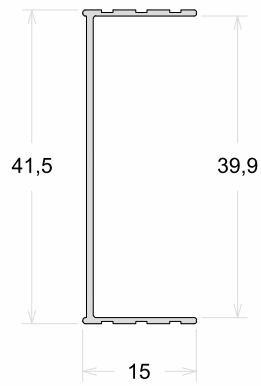

BX-158	Folha
Peso (Kg/m)	Perfis De Encaixe:
0,175	

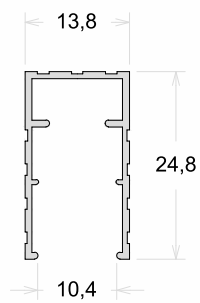

BX-002	Folha
Peso (Kg/m)	Perfis De Encaixe:
0,154	

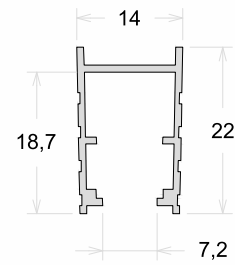

BX-155	Travessa Horizontal
Peso (Kg/m)	Perfis De Encaixe:
0,199	

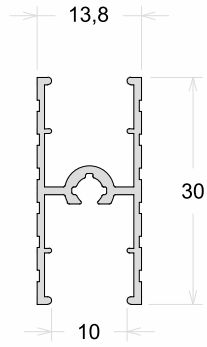

BX-004	Travessa Horizontal
Peso (Kg/m)	Perfis De Encaixe:
0,211	

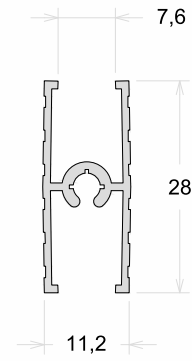

VZ-024	Veneziana
Peso (Kg/m)	Perfis De Encaixe:
0,207	

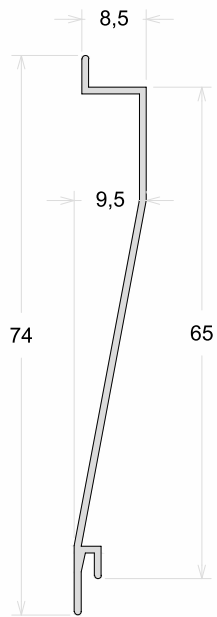

VZ-024 VT	Veneziana Ventilada
Peso (Kg/m)	Perfis De Encaixe:
0,252	

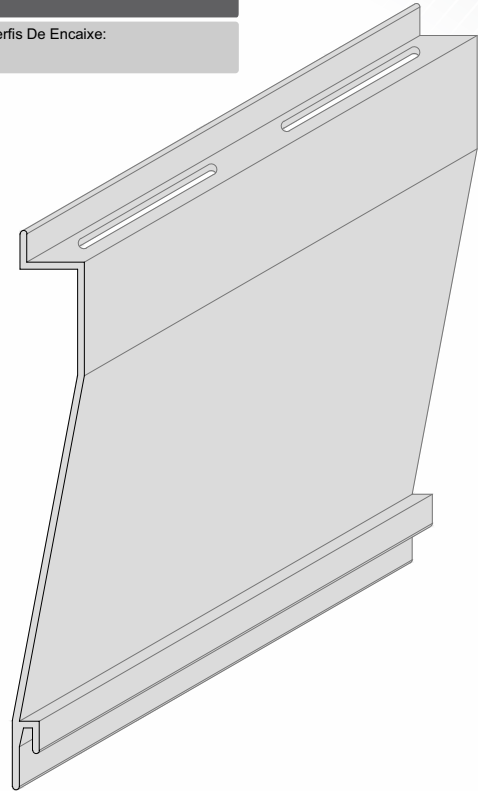

VZ-023	Veneziana
Peso (Kg/m)	Perfis De Encaixe:
0,240	

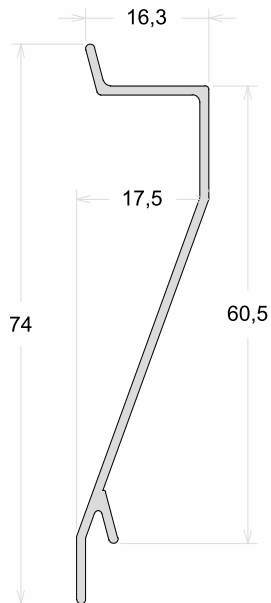

VZ-023 VT	Veneziana Ventilada
Peso (Kg/m)	Perfis De Encaixe:
0,240	

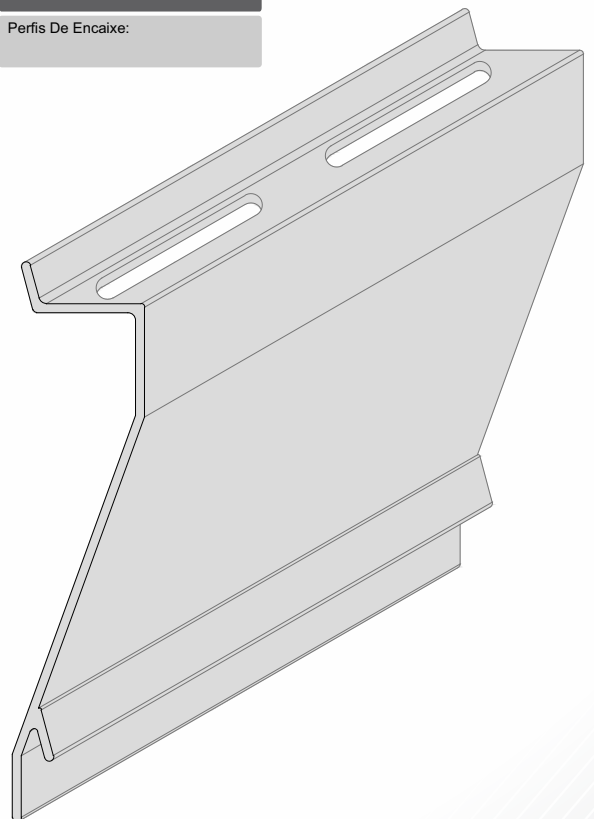

VZ-080	Veneziana
Peso (Kg/m)	Perfis De Encaixe:
0,222	

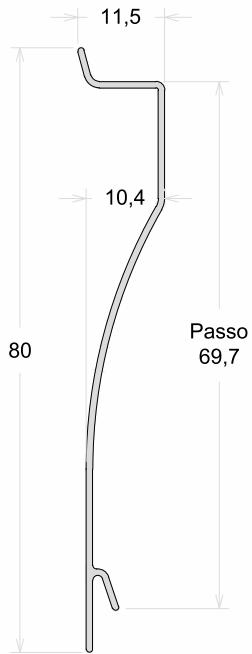

VZ-080 VT	Veneziana Ventilada
Peso (Kg/m)	Perfis De Encaixe:
0,222	

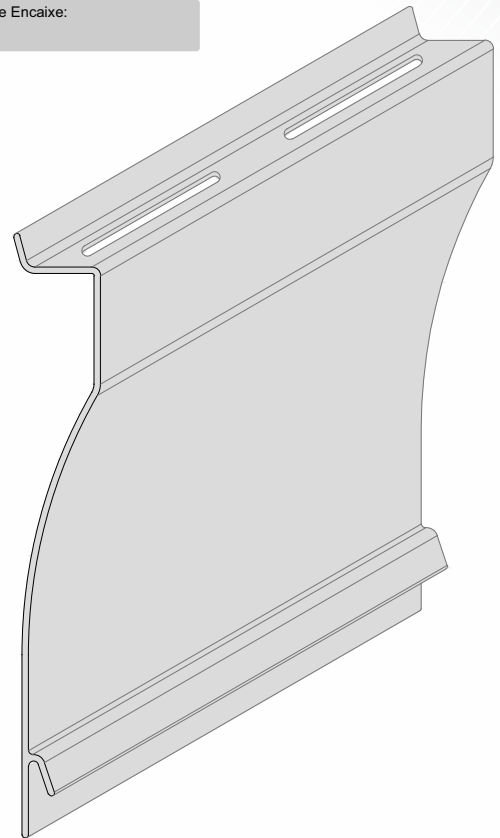

VZ-082	Veneziana
Peso (Kg/m)	Perfis De Encaixe:
0,280	



VZ-082 VT	Veneziana Ventilada
Peso (Kg/m)	Perfis De Encaixe:
0,280	

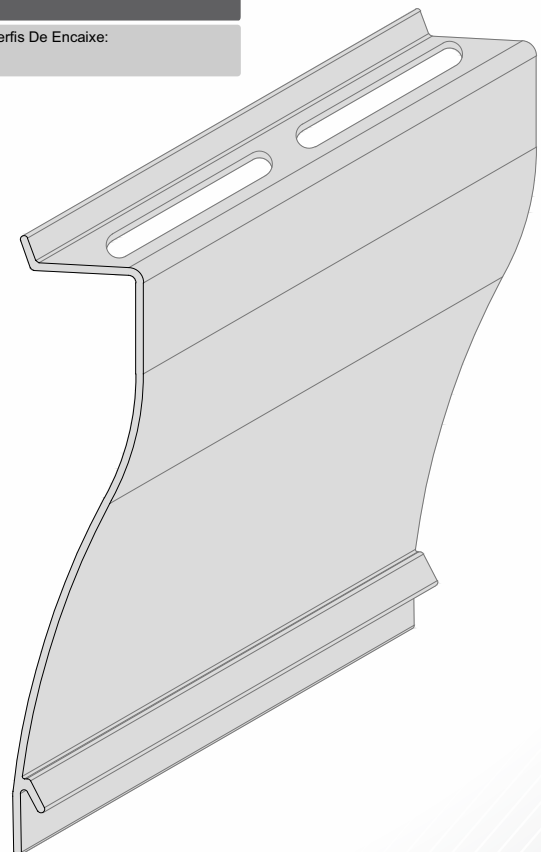

VZ-006	Veneziana
Peso (Kg/m)	Perfis De Encaixe:
0,269	

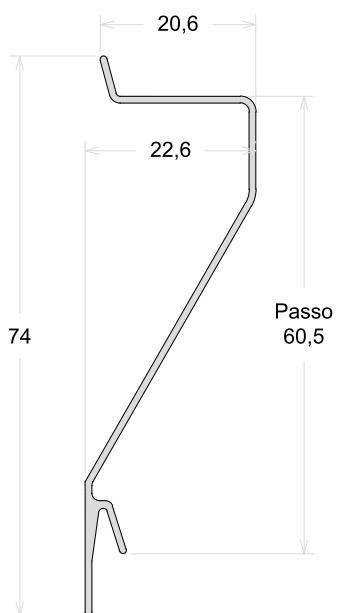

VZ-006 VT	Veneziana Ventilada
Peso (Kg/m)	Perfis De Encaixe:
0,269	

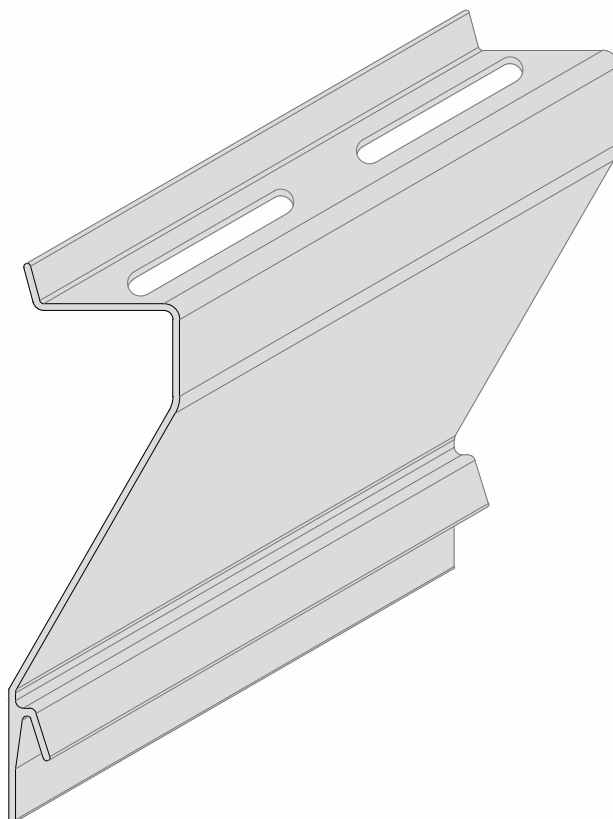

VZ-106	Veneziana
Peso (Kg/m)	Perfis De Encaixe:
0,405	

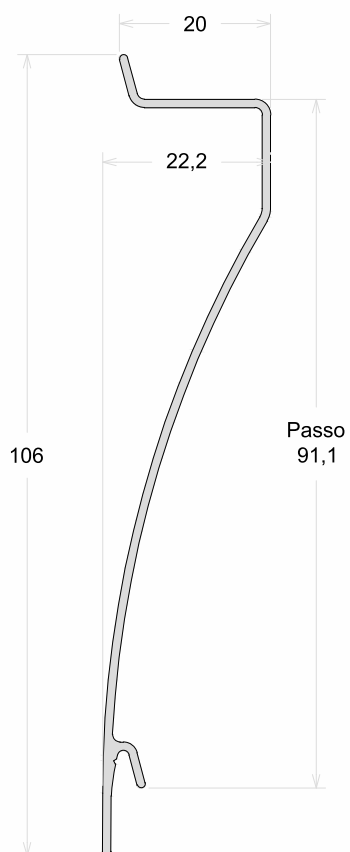

VZ-106 VT	Veneziana Ventilada
Peso (Kg/m)	Perfis De Encaixe:
0,405	

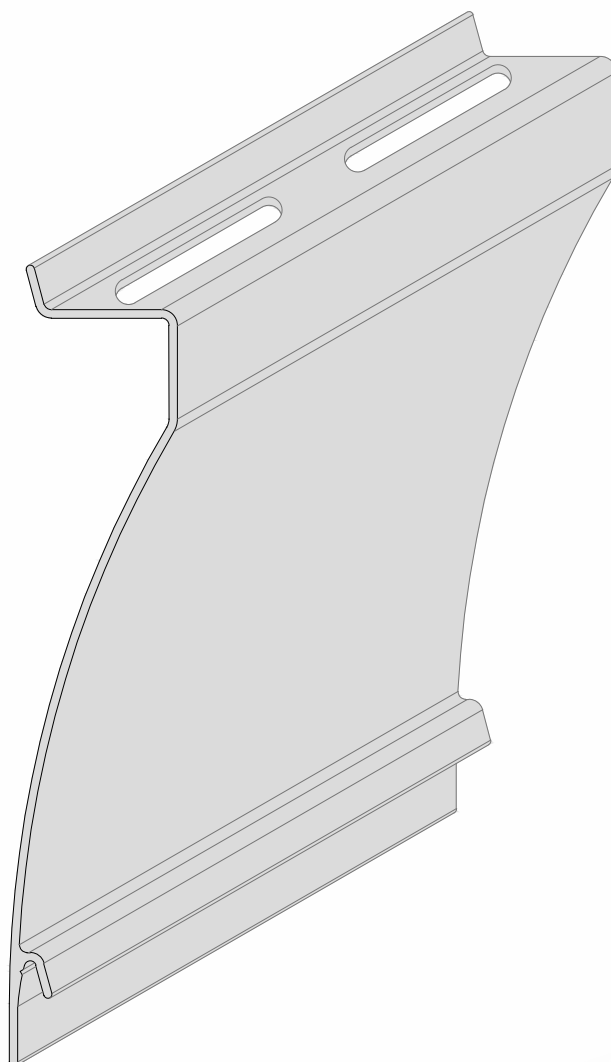

CX-642	Veneziana
Peso (Kg/m)	Perfis De Encaixe:
0,228	

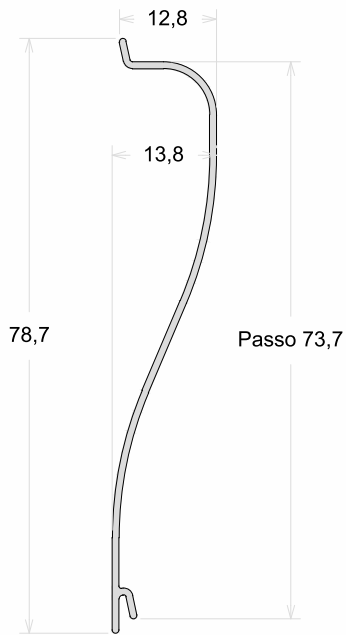

VZ-244	Veneziana
Peso (Kg/m)	Perfis De Encaixe:
0,224	

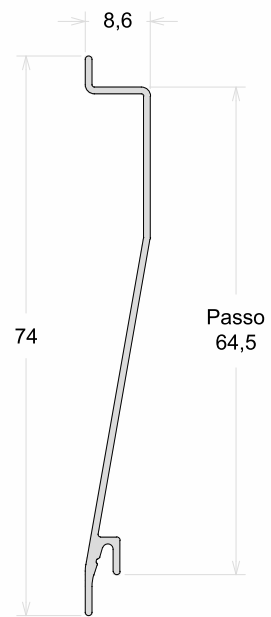

Z-284	Veneziana
Peso (Kg/m)	Perfis De Encaixe:
0,269	

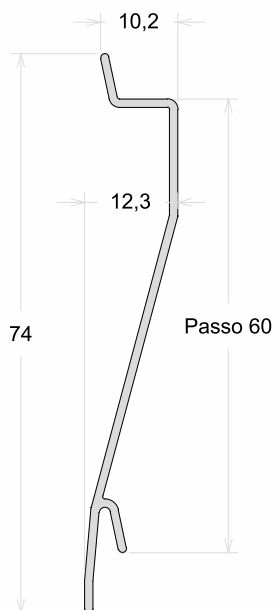

Z-163	Veneziana
Peso (Kg/m)	Perfis De Encaixe:
0,258	

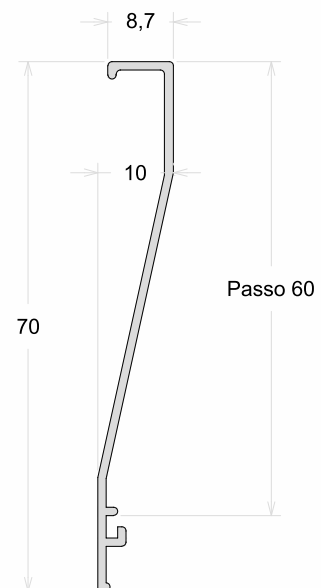

VZ-025	Veneziana
Peso (Kg/m)	Perfis De Encaixe:
0,164	

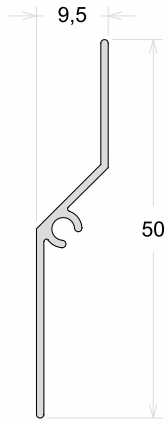

VZ-026	Veneziana
Peso (Kg/m)	Perfis De Encaixe:
0,326	

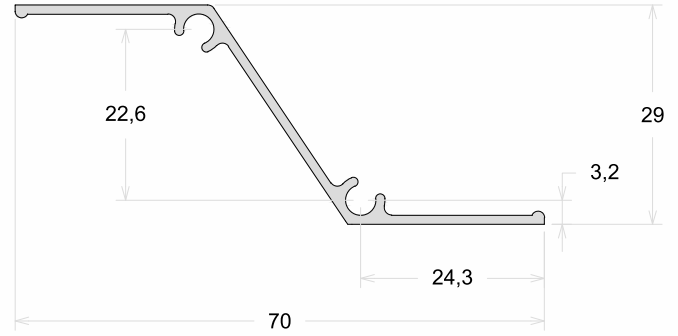

VZ-044	Veneziana
Peso (Kg/m)	Perfis De Encaixe:
0,270	

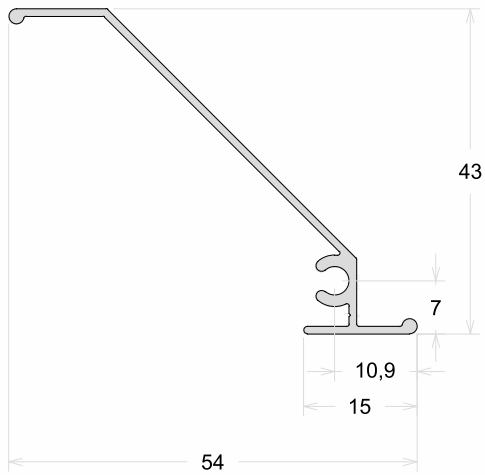

Z-248	Veneziana
Peso (Kg/m)	Perfis De Encaixe:
0,271	

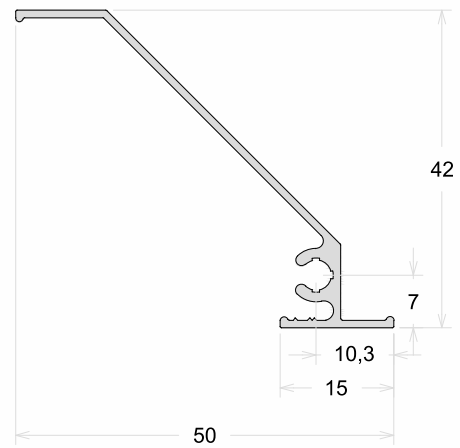

VZ-045	Veneziana
Peso (Kg/m)	Perfis De Encaixe:
0,351	

VZ-060	Veneziana
Peso (Kg/m)	Perfis De Encaixe:
0,279	

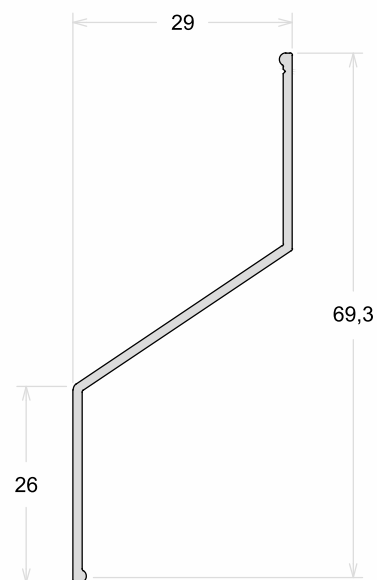
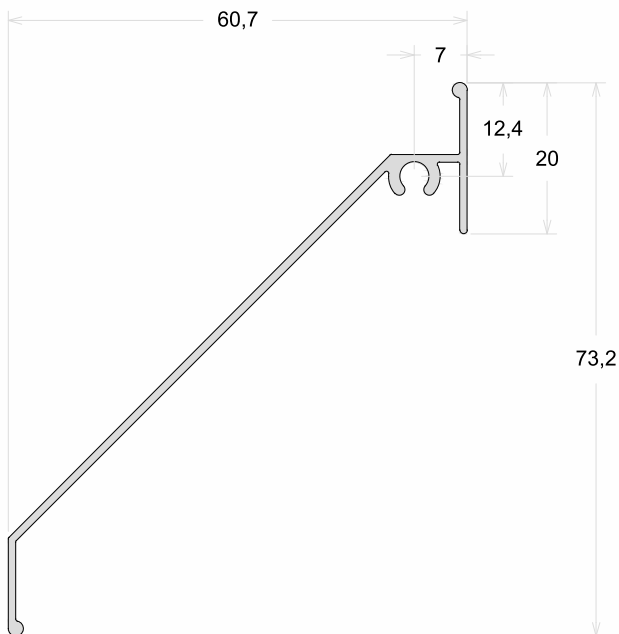

D-059	Brise Asa De Avião 100mm
Peso (Kg/m)	Perfis De Encaixe:
0,813	

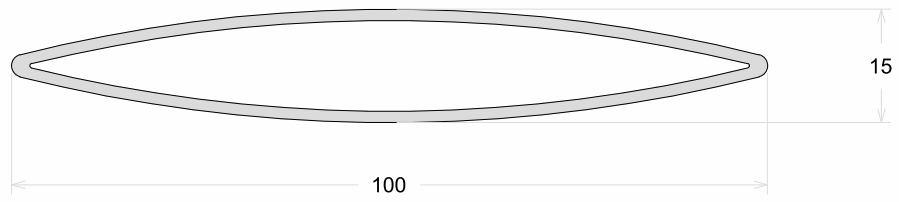

DC-006	Brise
Peso (Kg/m)	Perfis De Encaixe:
0,778	

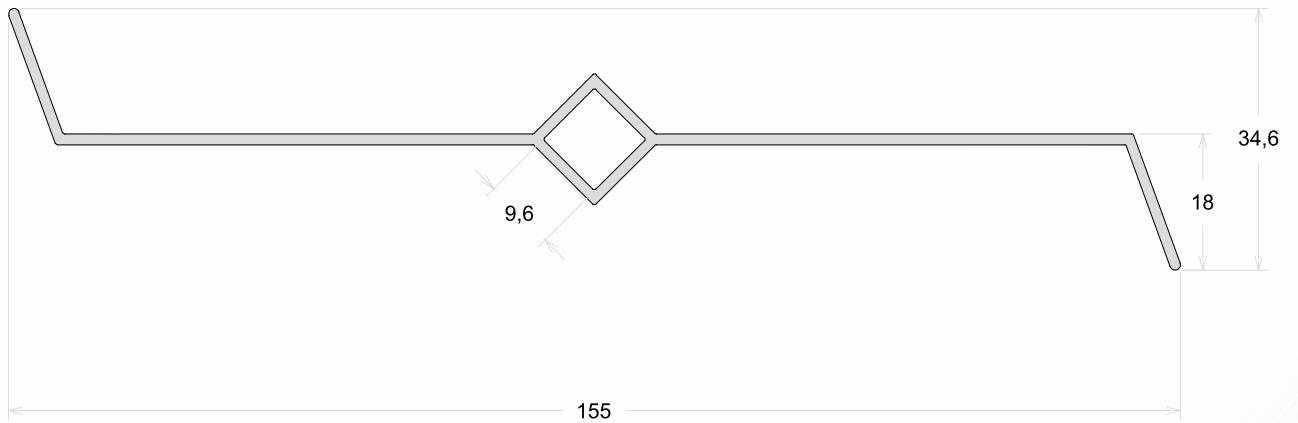

BX-010	Montante Lateral
Peso (Kg/m)	Perfis De Encaixe:
0,225	

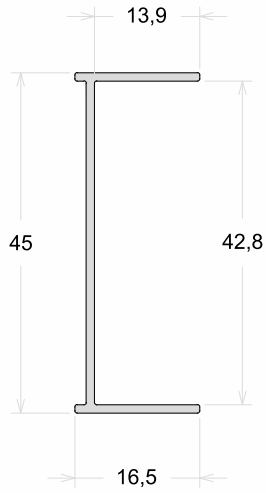

Z-248	Brise
Peso (Kg/m)	Perfis De Encaixe:
0,271	

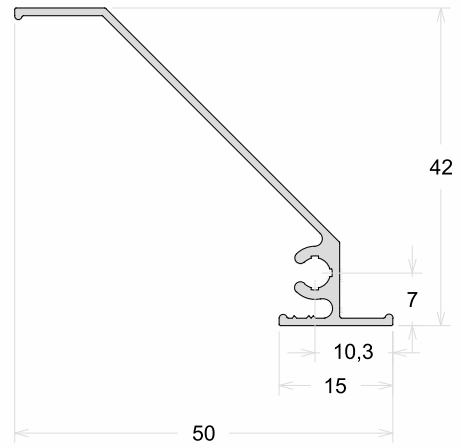

U-399	Montante Lateral
Peso (Kg/m)	Perfis De Encaixe:
0,274	

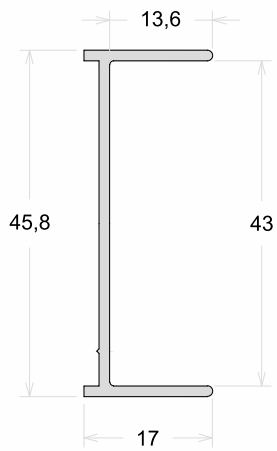

VZ-044	Brise
Peso (Kg/m)	Perfis De Encaixe:
0,270	

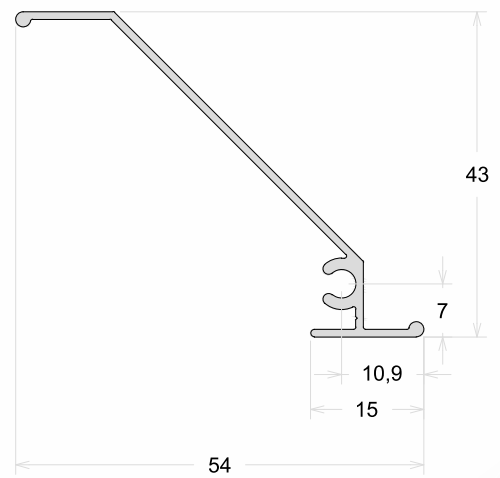

ME-024	Montante Lateral
Peso (Kg/m)	Perfis De Encaixe:
0,327	

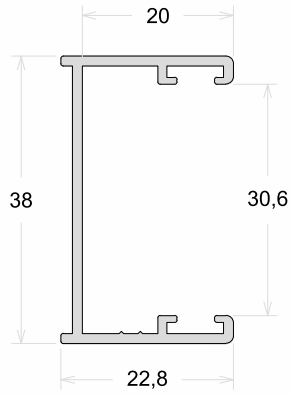

VZ-026	Brise
Peso (Kg/m)	Perfis De Encaixe:
0,326	

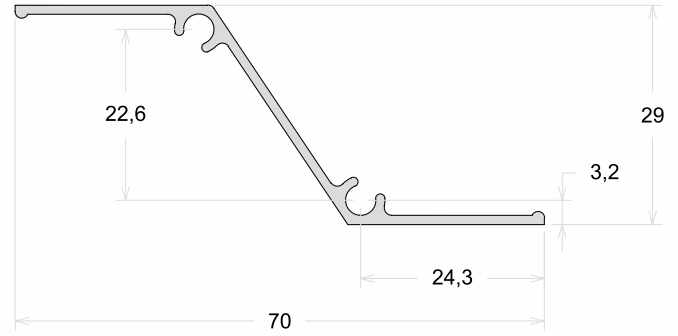

VZ-045	Brise
Peso (Kg/m)	Perfis De Encaixe:
0,351	

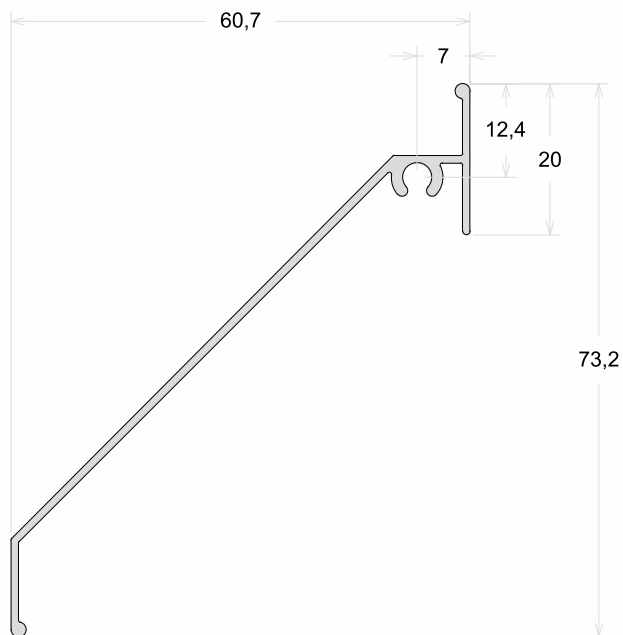

RPP-002	Ripado Clicado - 25 x 25
Peso (Kg/m)	Perfis De Encaixe: RPP-002
0,160	

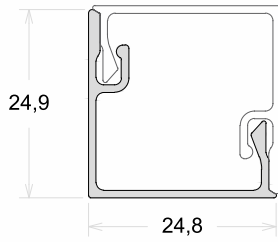

RPP-001	Ripado Clicado - 50 x 25
Peso (Kg/m)	Perfis De Encaixe: RPP-001
0,231	

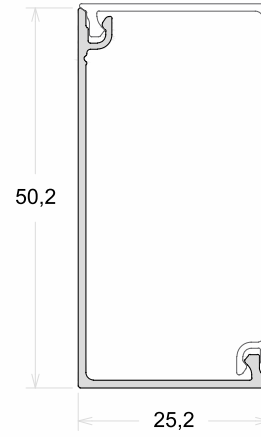

TP-160	Ripado
Peso (Kg/m)	Perfis De Encaixe:
0,556	

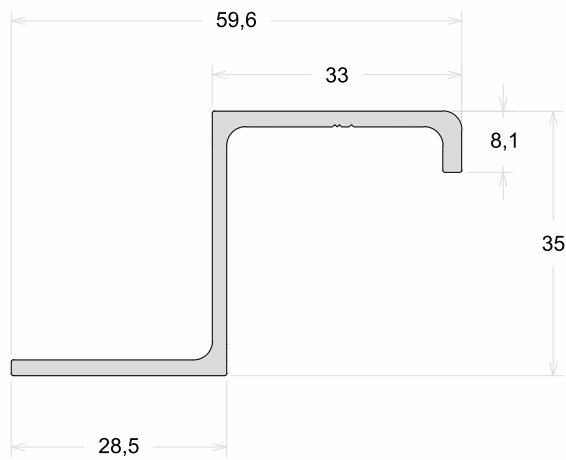

CT-005	Acabamento Ripado
Peso (Kg/m)	Perfis De Encaixe:
0,100	

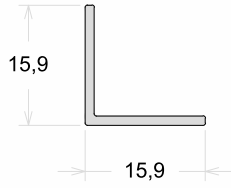

PLB-075	PLB-075L	Lambri Ripado
Peso (Kg/m)	Peso (Kg/m)	Perfis De Encaixe:
1,022	0,887	

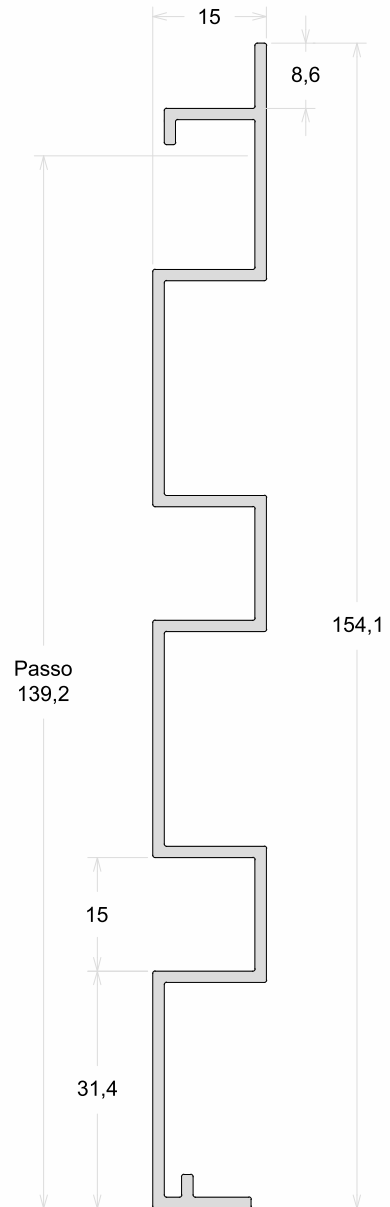

PLB-085	Lambri Duplo Ripado
Peso (Kg/m)	Perfis De Encaixe:
0,933	

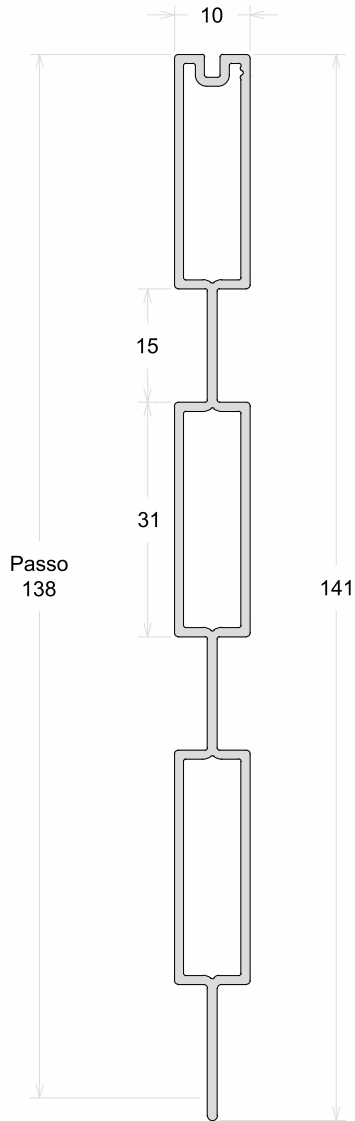

PLB-090	Lambri Ripado Slim
Peso (Kg/m)	Perfis De Encaixe:
1,067	

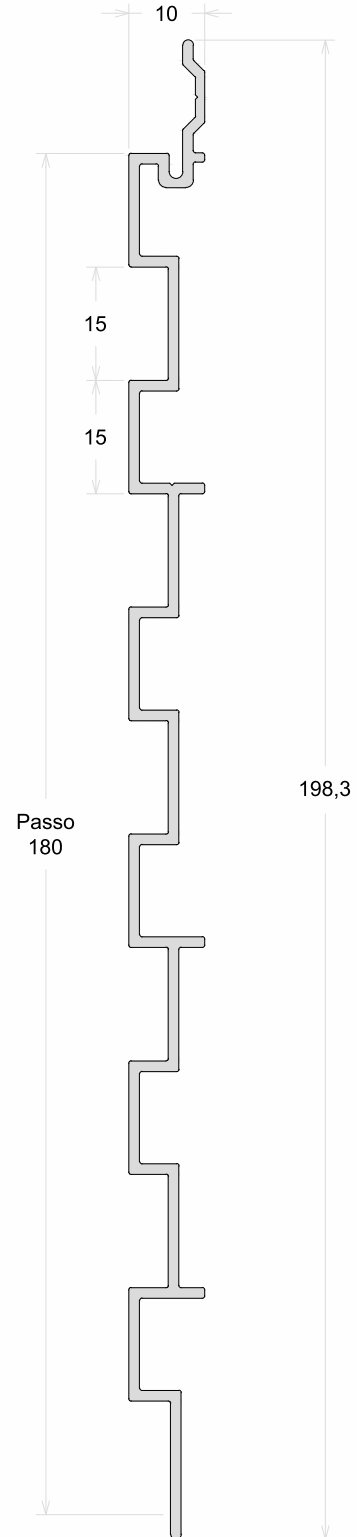

PLB-092	Lambri Ripado 50 x 25
Peso (Kg/m)	Perfis De Encaixe:
0,823	

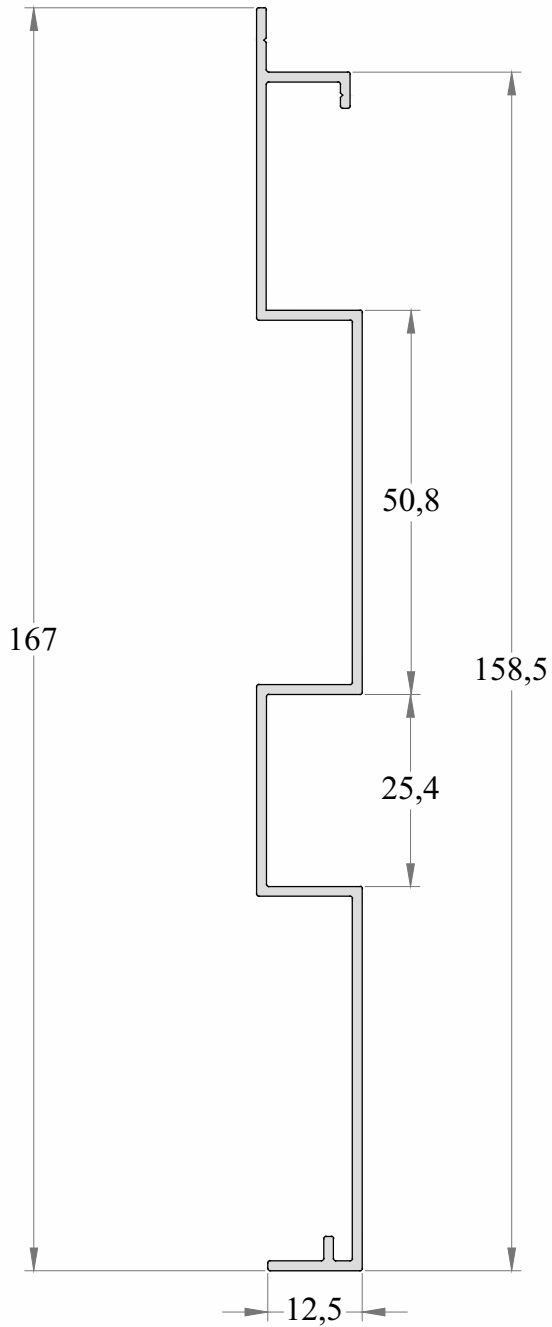

PLB-200	Lambri Ripado 43 x 20
Peso (Kg/m)	Perfis De Encaixe:
1,055	

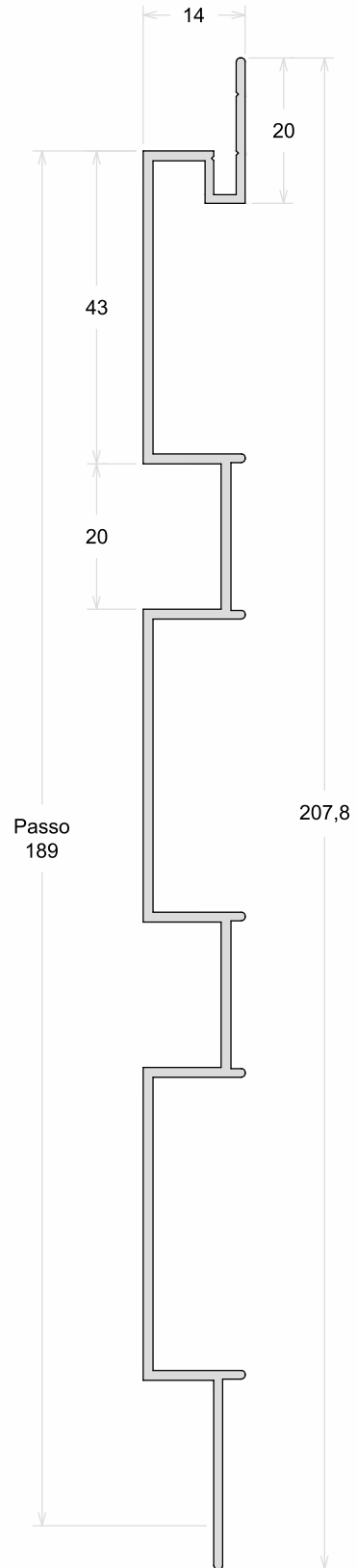

CG-015	Acabamento Ripado
Peso (Kg/m)	Perfis De Encaixe:
0,164	

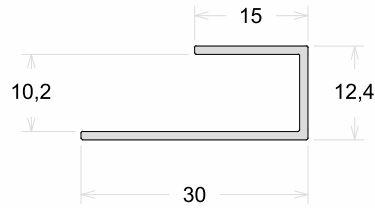

DV-014	Complemento Ripado
Peso (Kg/m)	Perfis De Encaixe:
0,343	PLB-075 / PLG-043 / PLG-239

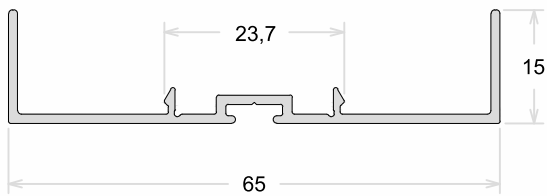

DV-013	Complemento Ripado
Peso (Kg/m)	Perfis De Encaixe:
0,320	PLB-075 / PLG-043 / PLG-239

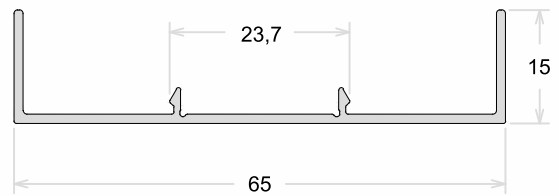

RPP-003	Ripado Muxarabi
Peso (Kg/m)	Perfis De Encaixe:
0,538	

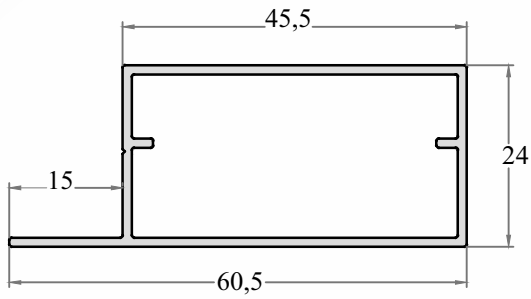

RPP-004	Ripado Muxarabi
Peso (Kg/m)	Perfis De Encaixe:
0,161	RPP-007

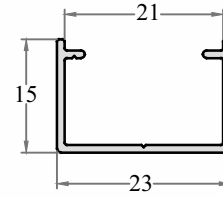

RPP-005	Ripado Muxarabi
Peso (Kg/m)	Perfis De Encaixe:
0,133	RPP-007

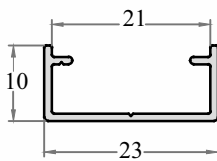

RPP-007	Ripado Muxarabi
Peso (Kg/m)	Perfis De Encaixe:
0,083	

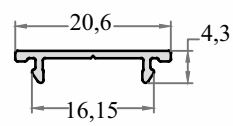

PLB-002	Lambri Búzios
Peso (Kg/m)	Perfis De Encaixe:
0,607	

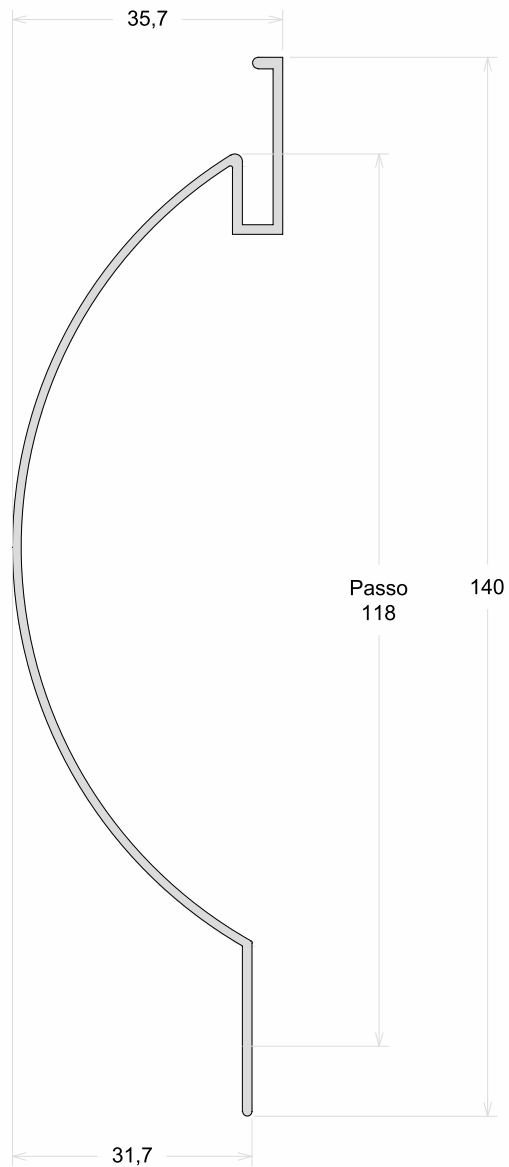

PLB-035	Lambri Liso
Peso (Kg/m)	Perfis De Encaixe:
0,537	

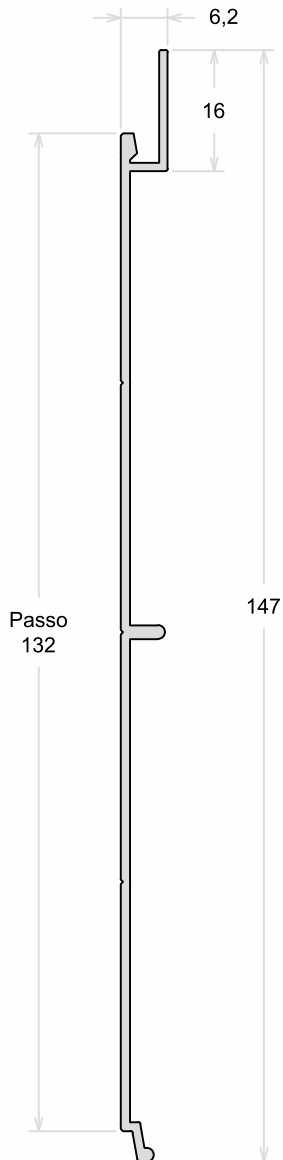

PLB-050	Lambri Frisado
Peso (Kg/m)	Perfis De Encaixe:
0,521	

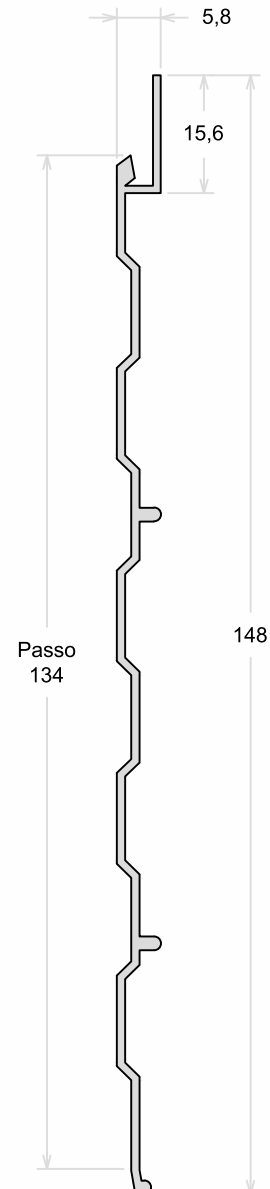

PPO-001	Lambri Negativo
Peso (Kg/m)	Perfis De Encaixe:
1,612	

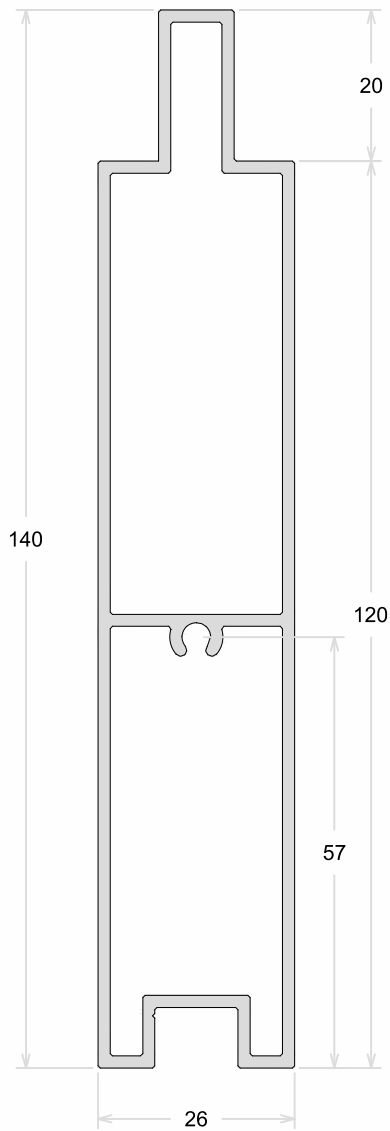

PPO-006	Lambri Liso
Peso (Kg/m)	Perfis De Encaixe:
1,612	

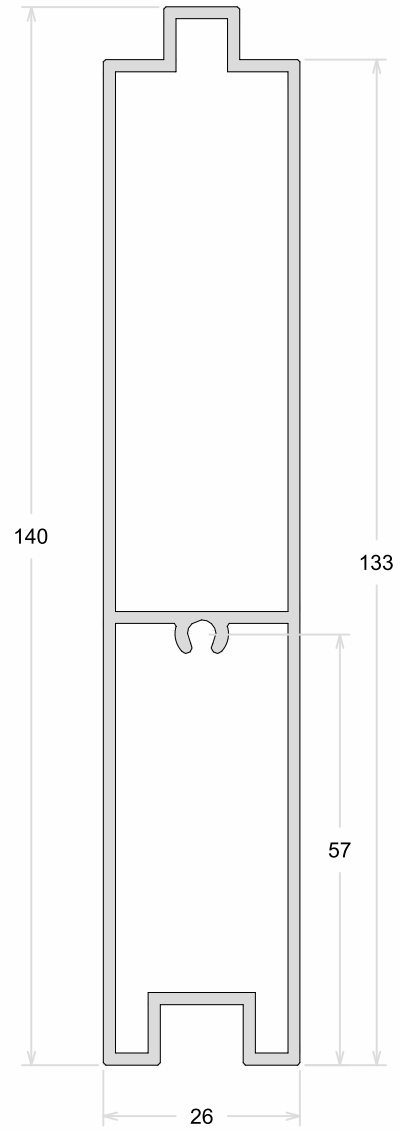

PPO-015	Lambri Friso
Peso (Kg/m)	Perfis De Encaixe:
0,449	PPO-006

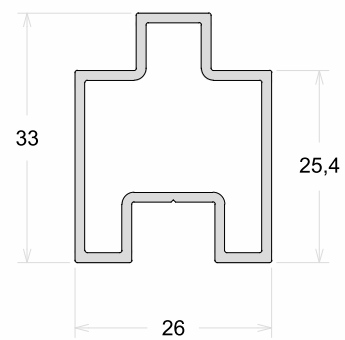

PEI-010	Lambri Duplo
Peso (Kg/m)	Perfis De Encaixe:
1,315	

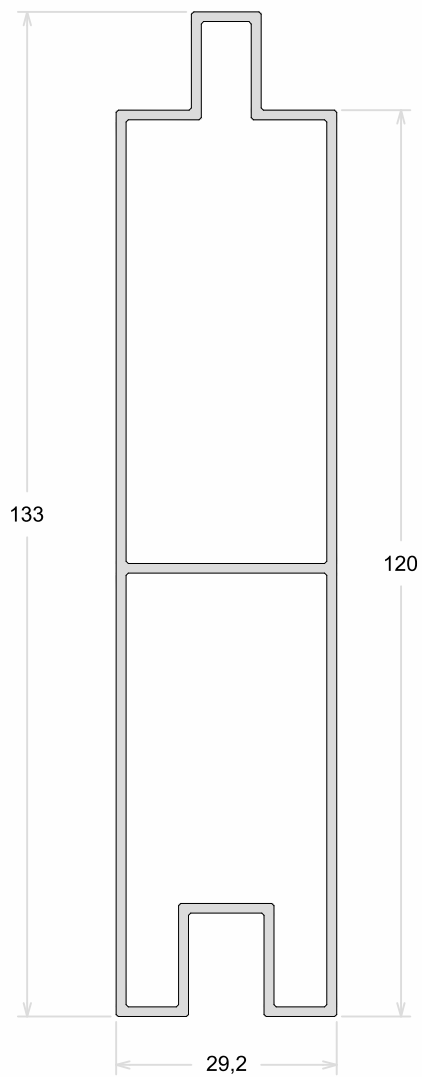

PEI-014	Lambri Friso
Peso (Kg/m)	Perfis De Encaixe:
0,495	

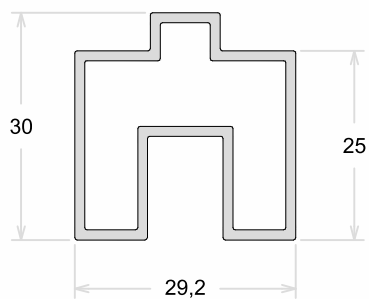

PLB-091	Lambri Frisado
Peso (Kg/m)	Perfis De Encaixe:
0,584	

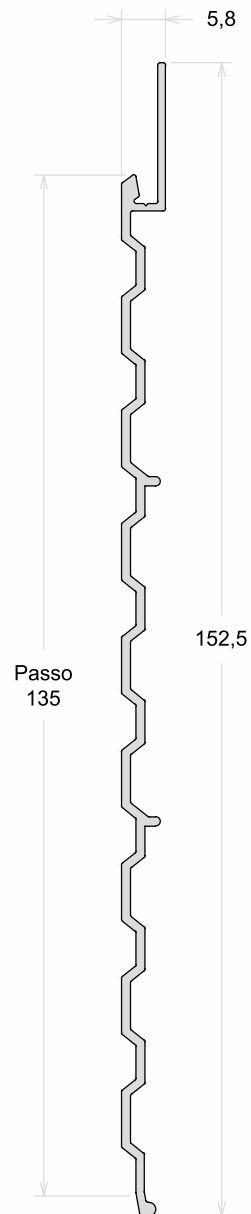

PLB-060	PLB-060L	Lambri Duplo Frisado
Peso (Kg/m)	Peso (Kg/m)	Perfis De Encaixe:
0,594	0,478	

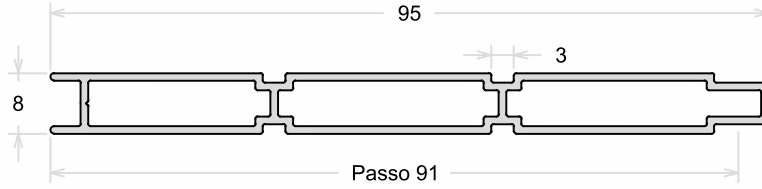

PLB-061	Lambri Duplo Liso
Peso (Kg/m)	Perfis De Encaixe:
0,671	

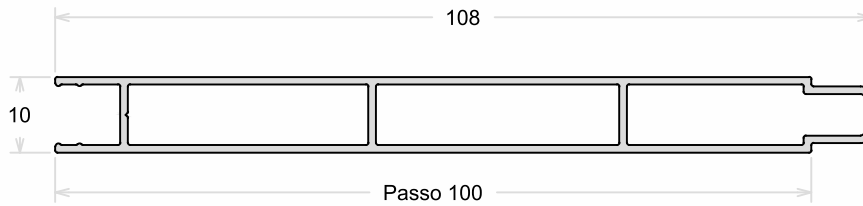

PLB-062	Lambri Duplo - Friso
Peso (Kg/m)	Perfis De Encaixe:
0,225	

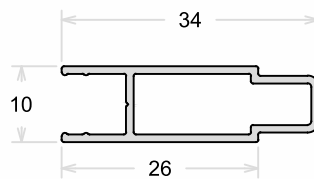

PLB-085

Lambri Ripado Duplo

Peso

(Kg/m)

0,933

Perfis De Encaixe:

PLB-090

Lambri Ripado Slim

Peso

(Kg/m)

1,067

Perfis De Encaixe:

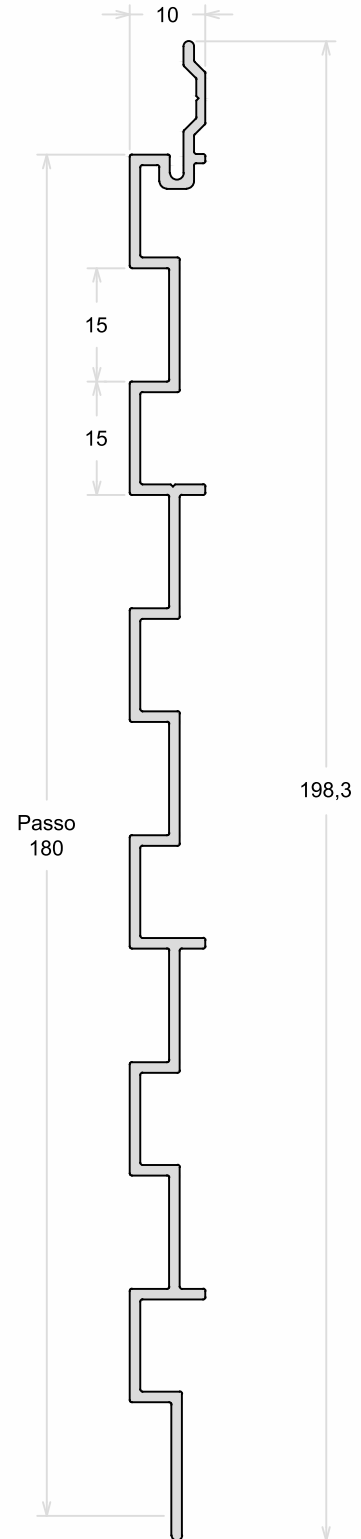
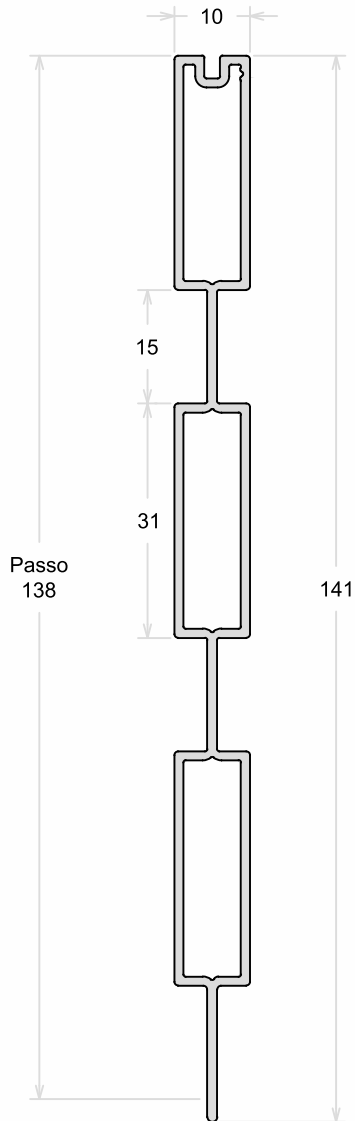

PLB-075	PLB-075L	Lambri Ripado
Peso (Kg/m)	Peso (Kg/m)	Perfis De Encaixe:
1,022	0,887	

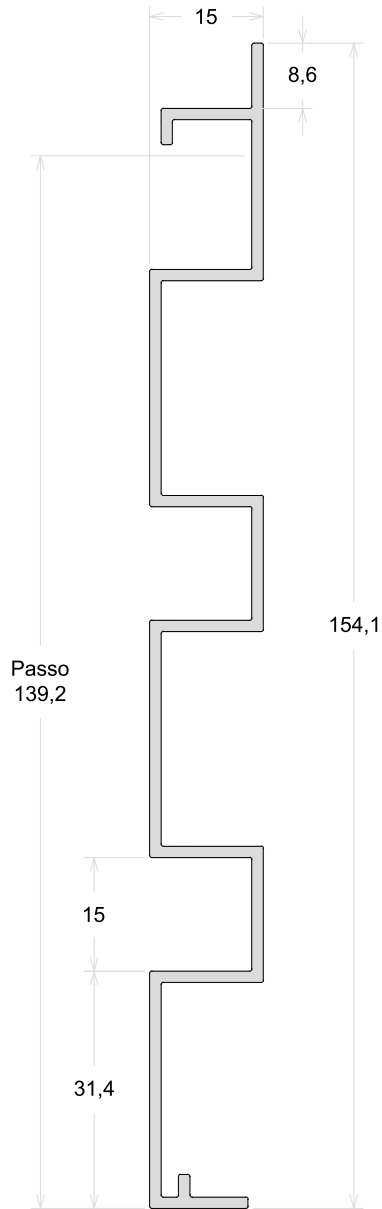

PLB-080

Lambri Duplo Liso

Peso
(Kg/m)

1,259

Perfis De Encaixe:

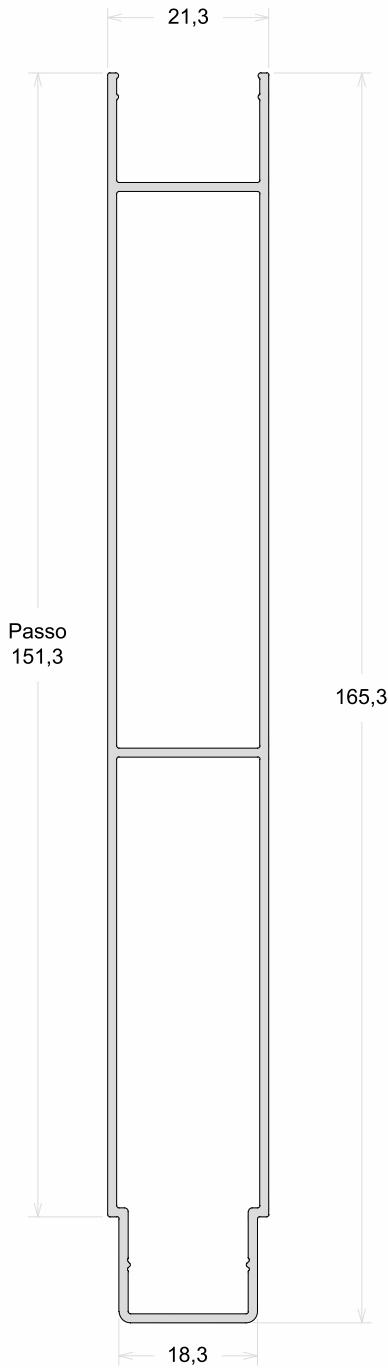

PLB-070

Lambri Duplo Com Negativo

Peso
(Kg/m)

1,894

Perfis De Encaixe:

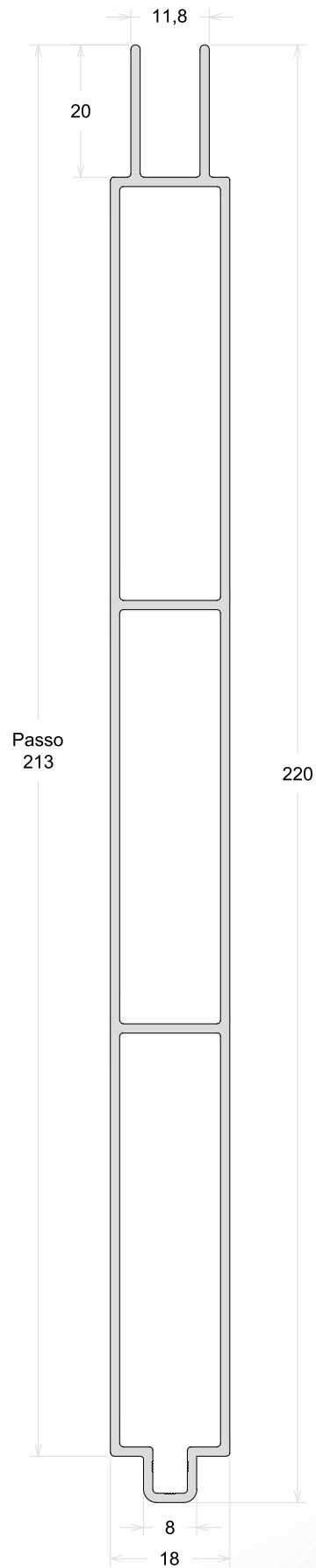

PLB-020	Lambri Duplo 160mm
Peso (Kg/m)	Perfis De Encaixe:
1,422	

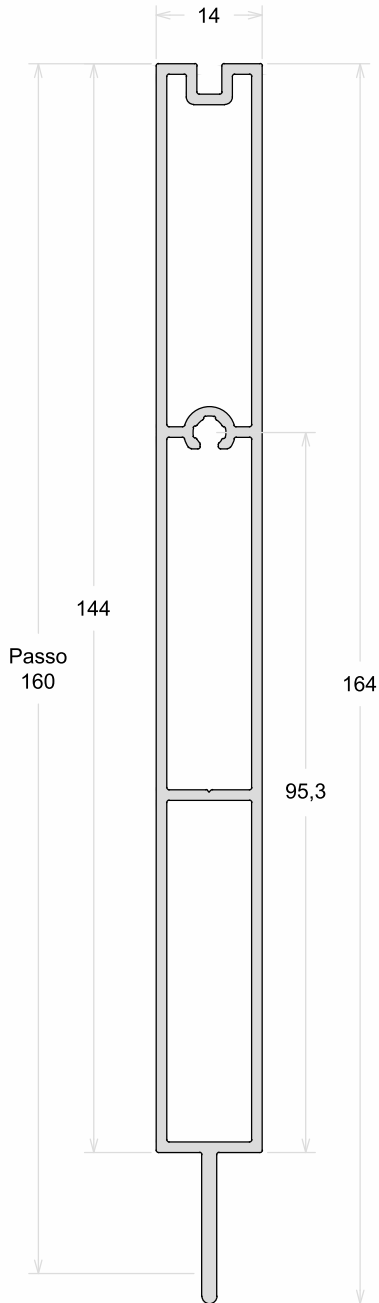

PLB-030	Lambri Duplo 216mm
Peso (Kg/m)	Perfis De Encaixe:
1,889	

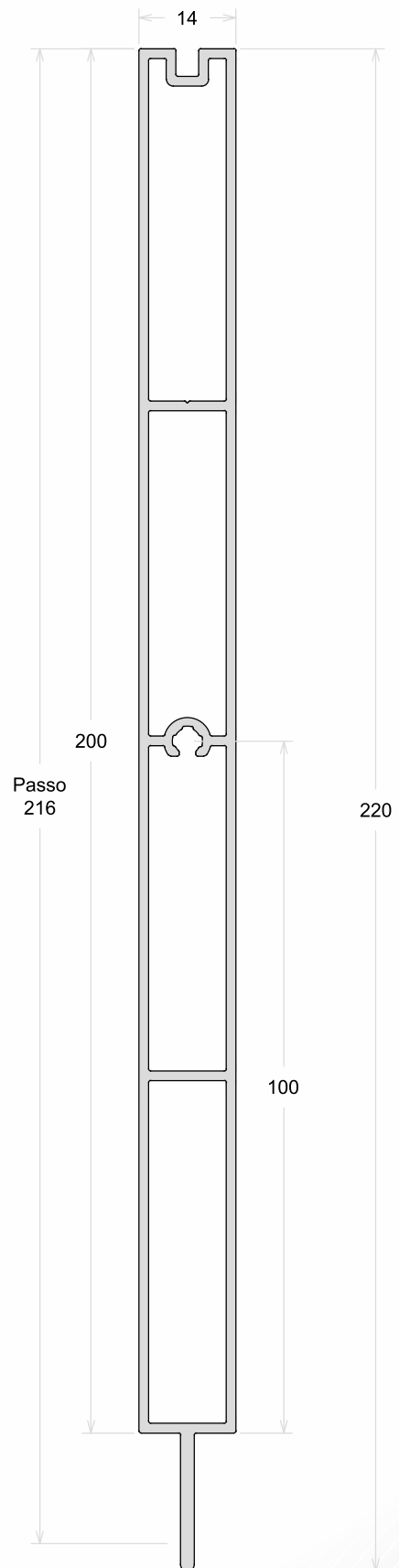

PLB-065	Lambri
Peso (Kg/m)	Perfis De Encaixe:
0,970	

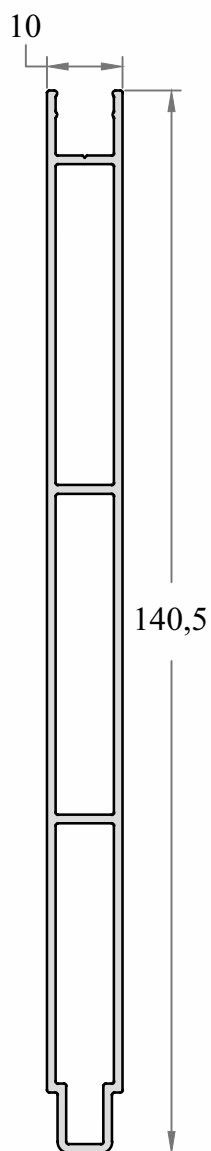

PLB-045	Lambri
Peso (Kg/m)	Perfis De Encaixe:
0,650	

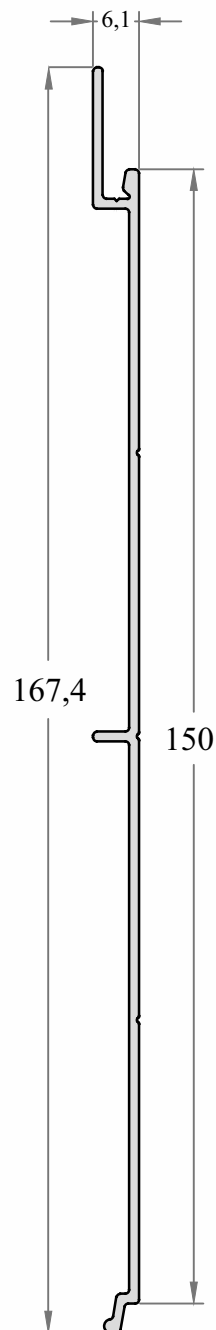

PLB-036	Lambri
Peso (Kg/m)	Perfis De Encaixe:
0,582	

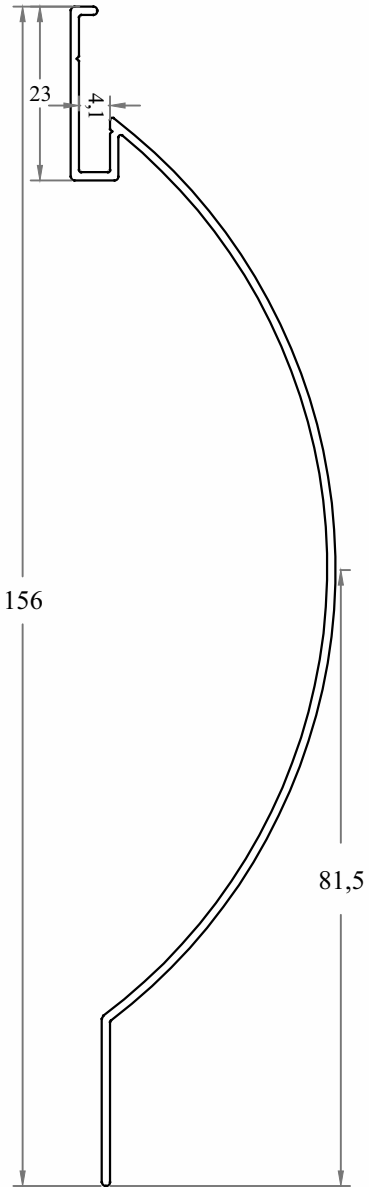

PLB-051	Lambri
Peso (Kg/m)	Perfis De Encaixe:
0,528	

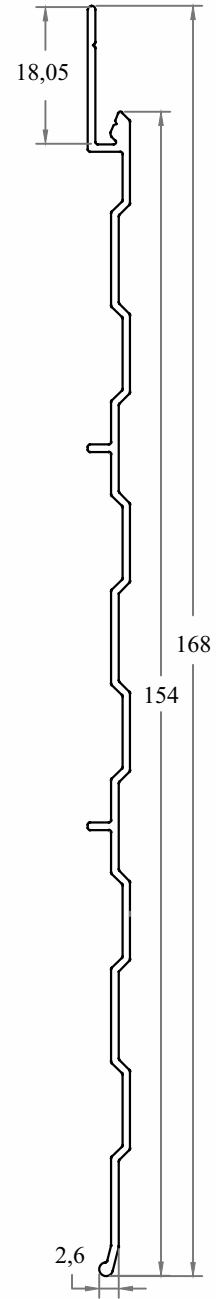

PLB-066	Lambri
Peso (Kg/m)	Perfis De Encaixe:
0,638	

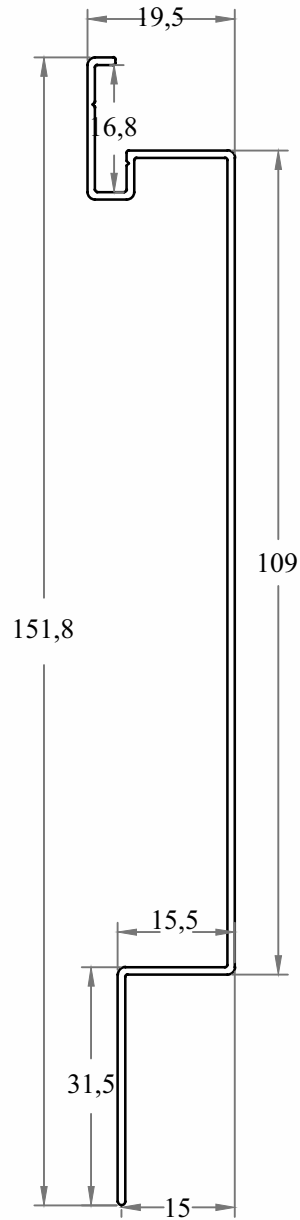

PLB-208	Lambri
Peso (Kg/m)	Perfis De Encaixe:
1,127	

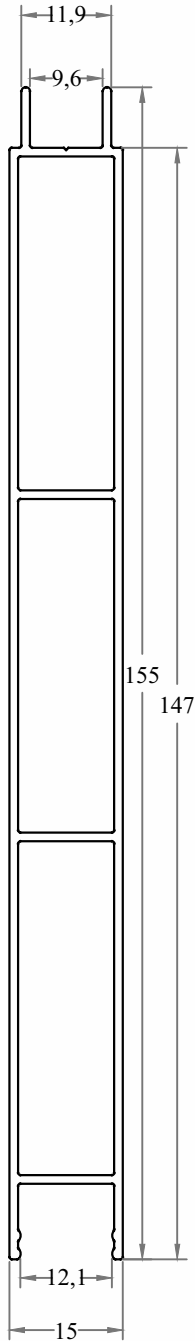

PLB-042	Lambri
Peso (Kg/m)	Perfis De Encaixe:
1,382	

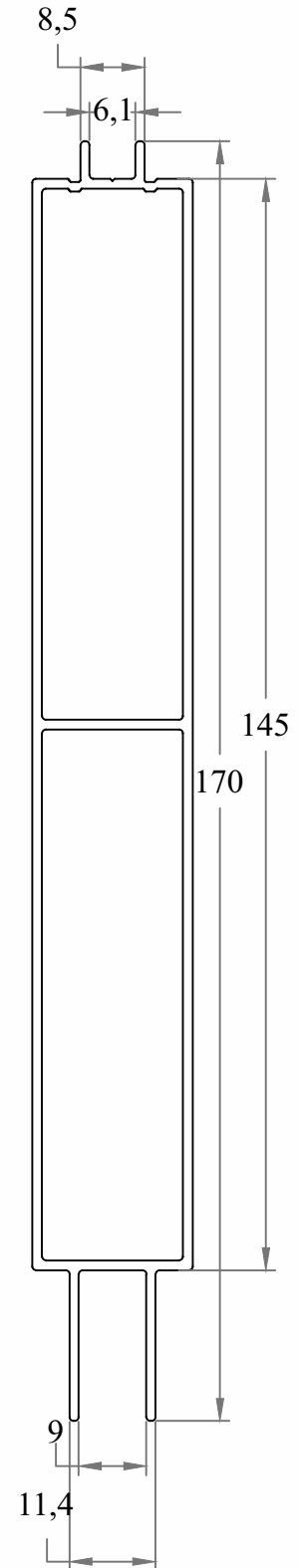

PLB-005	Lambri
Peso (Kg/m)	Perfis De Encaixe:
0,445	

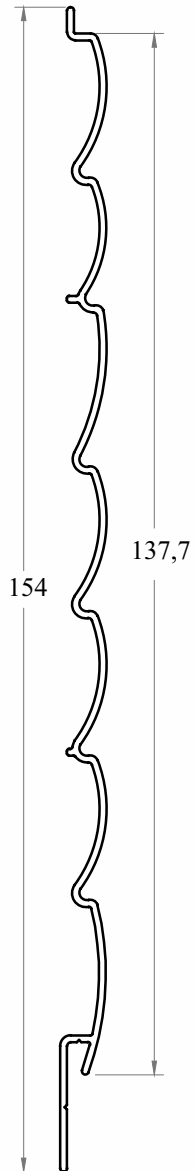

PLB-037	Lambri
Peso (Kg/m)	Perfis De Encaixe:
0,622	

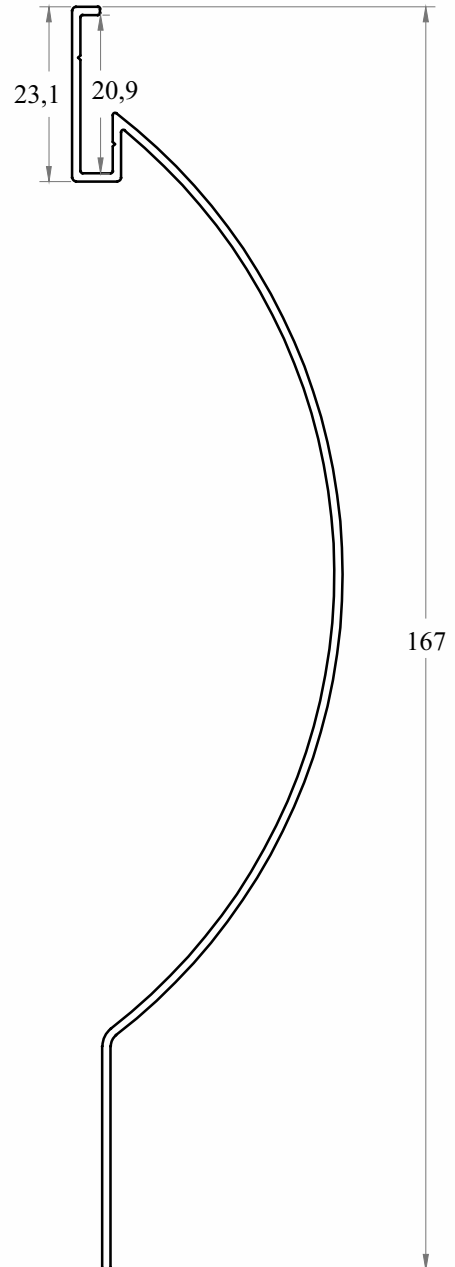

CX-152	CX-152B	Trilho Superior
Peso (Kg/m)	Peso (Kg/m)	Perfis De Encaixe:
0,602	0,715	

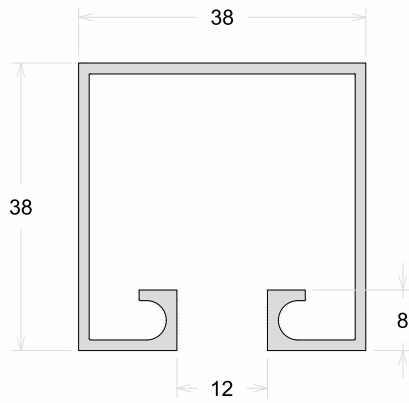

CX-1226L	Trilho Superior
Peso (Kg/m)	Perfis De Encaixe:
0,378	

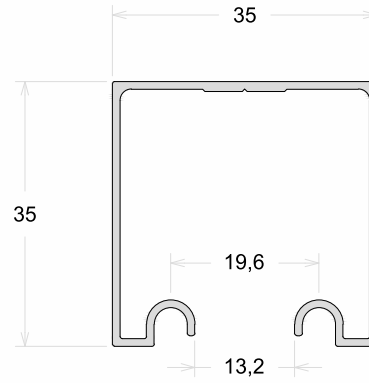

CX-1226	Trilho Superior
Peso (Kg/m)	Perfis De Encaixe:
0,441	

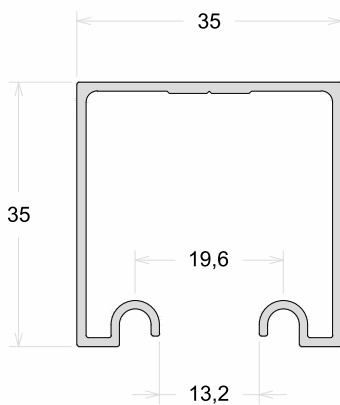

CX-897	Trilho Superior
Peso (Kg/m)	Perfis De Encaixe:
0,550	

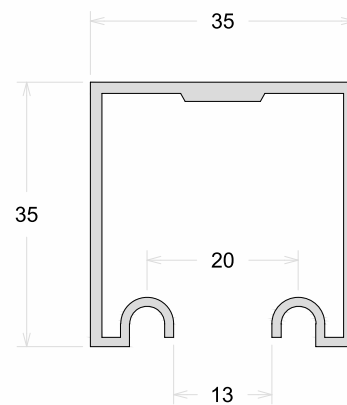

PC-006	Trilho Inferior
Peso (Kg/m)	Perfis De Encaixe:
0,330	

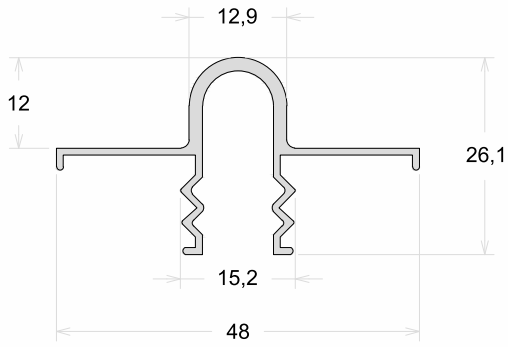

PC-007	Trilho Inferior
Peso (Kg/m)	Perfis De Encaixe:
0,259	

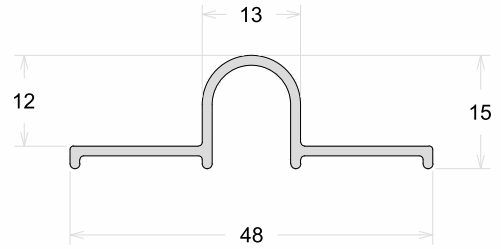

ME-024	Montante Vertical
Peso (Kg/m)	Perfis De Encaixe:
0,327	

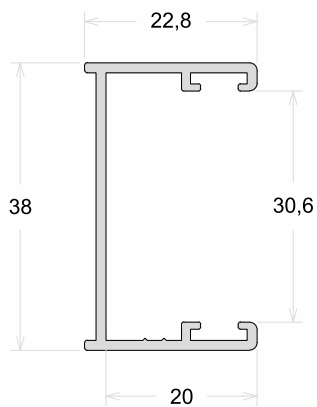

ME-025	Montante Vertical
Peso (Kg/m)	Perfis De Encaixe:
0,385	

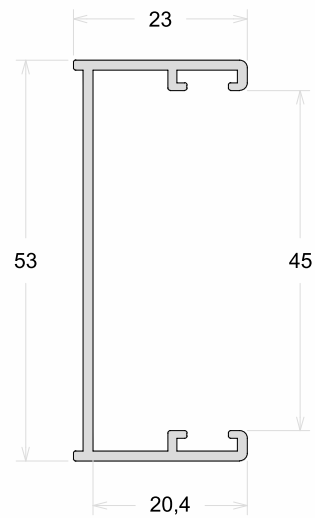

CX-306	Quadro Portão
Peso (Kg/m)	Perfis De Encaixe:
0,784	

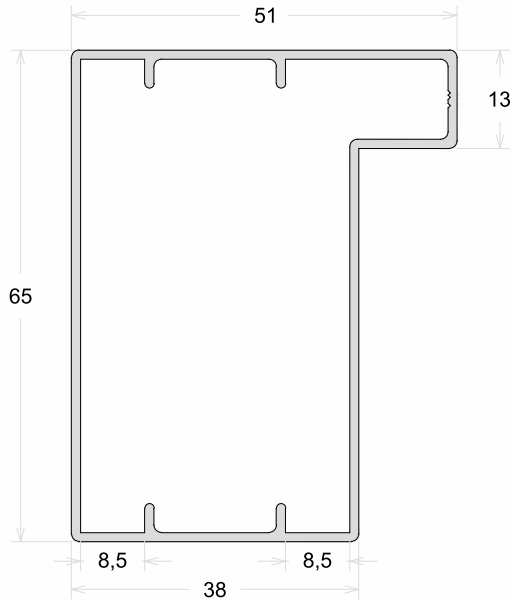

PC-010	Quadro Portão
Peso (Kg/m)	Perfis De Encaixe:
0,794	

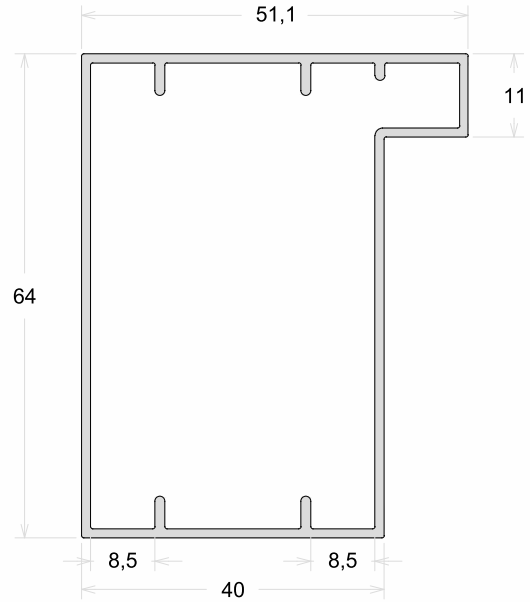

PC-011	Quadro Portão
Peso (Kg/m)	Perfis De Encaixe:
1,037	

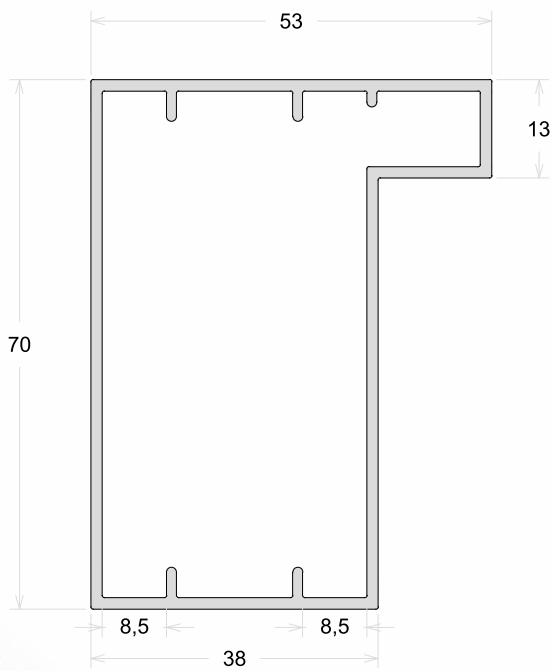

FC-070	Coluna
Peso (Kg/m)	Perfis De Encaixe:
0,756	

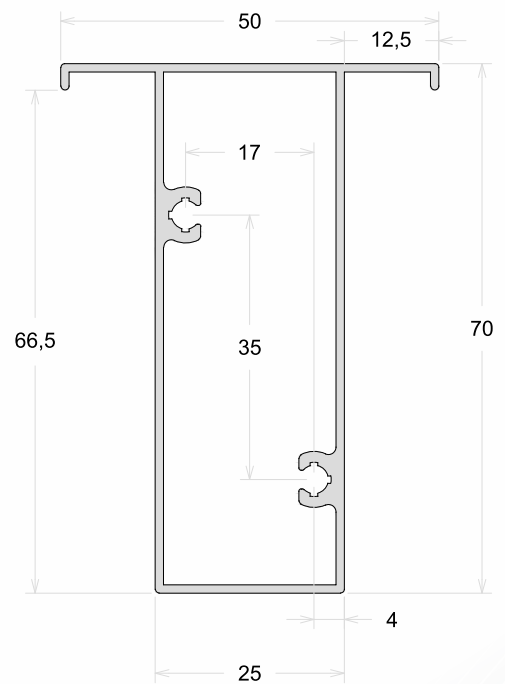

PC-002	PC-020	Requadro 50x25
Peso (Kg/m)	Peso (Kg/m)	Perfis De Encaixe:
0,460	0,606	

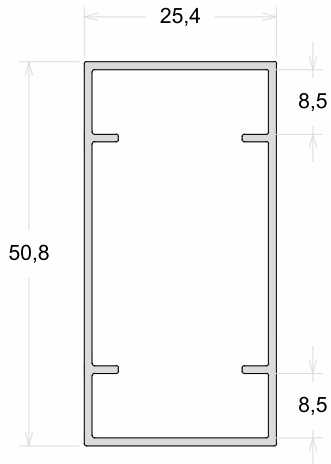

PC-004L	PC-004	PC-040	Requadro 50x38
Peso (Kg/m)	Peso (Kg/m)	Peso (Kg/m)	Perfis De Encaixe:
0,523	0,567	0,703	

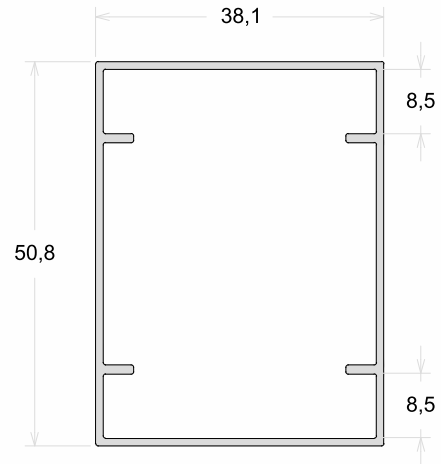

D-102	Requadro 38x38
Peso (Kg/m)	Perfis De Encaixe:
0,627	

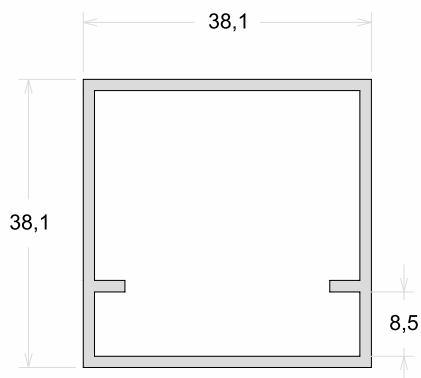

PC-003L	PC-003	D-069	Requadro 76x38
Peso (Kg/m)	Peso (Kg/m)	Peso (Kg/m)	Perfis De Encaixe:
0,722	0,895	1,043	

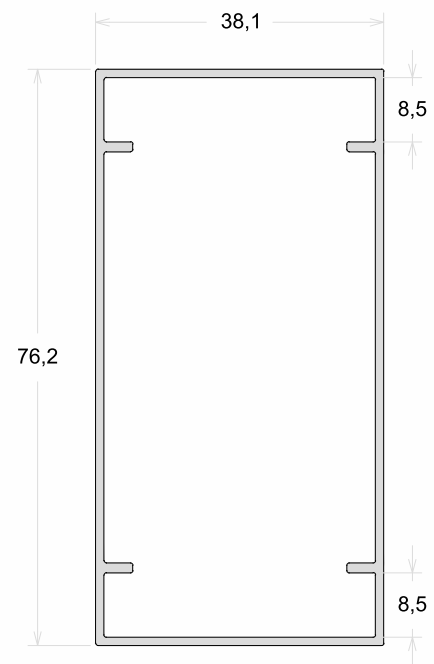

PC-055	Requadro 50x50
Peso (Kg/m)	Perfis De Encaixe:
0,850	

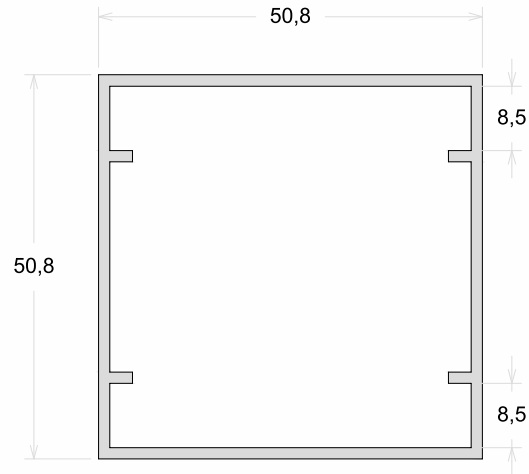

PC-100	Requadro 100x50
Peso (Kg/m)	Perfis De Encaixe:
1,189	

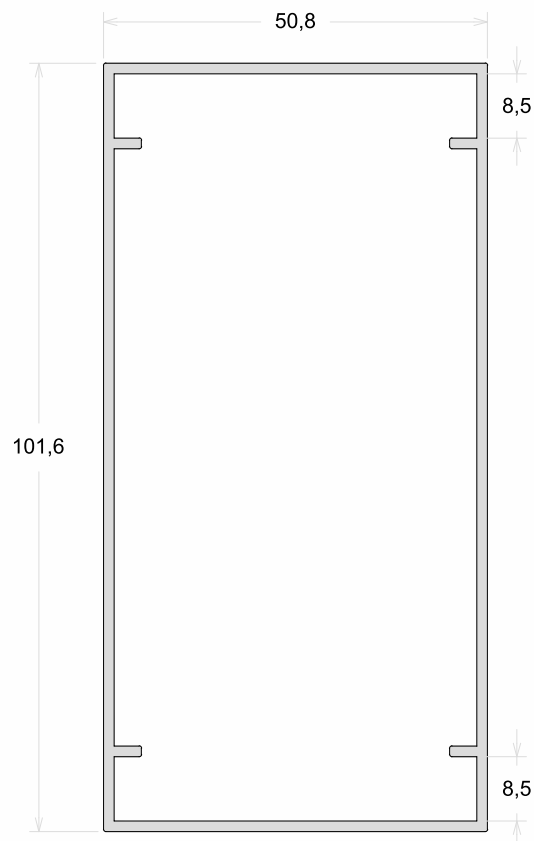

PEL-001	Tampa Da Caixa Do Portão
Peso (Kg/m)	Perfis De Encaixe:
1,372	



PEL-002	Caixa Do Portão Basculante
Peso (Kg/m)	Perfis De Encaixe:
2,930	

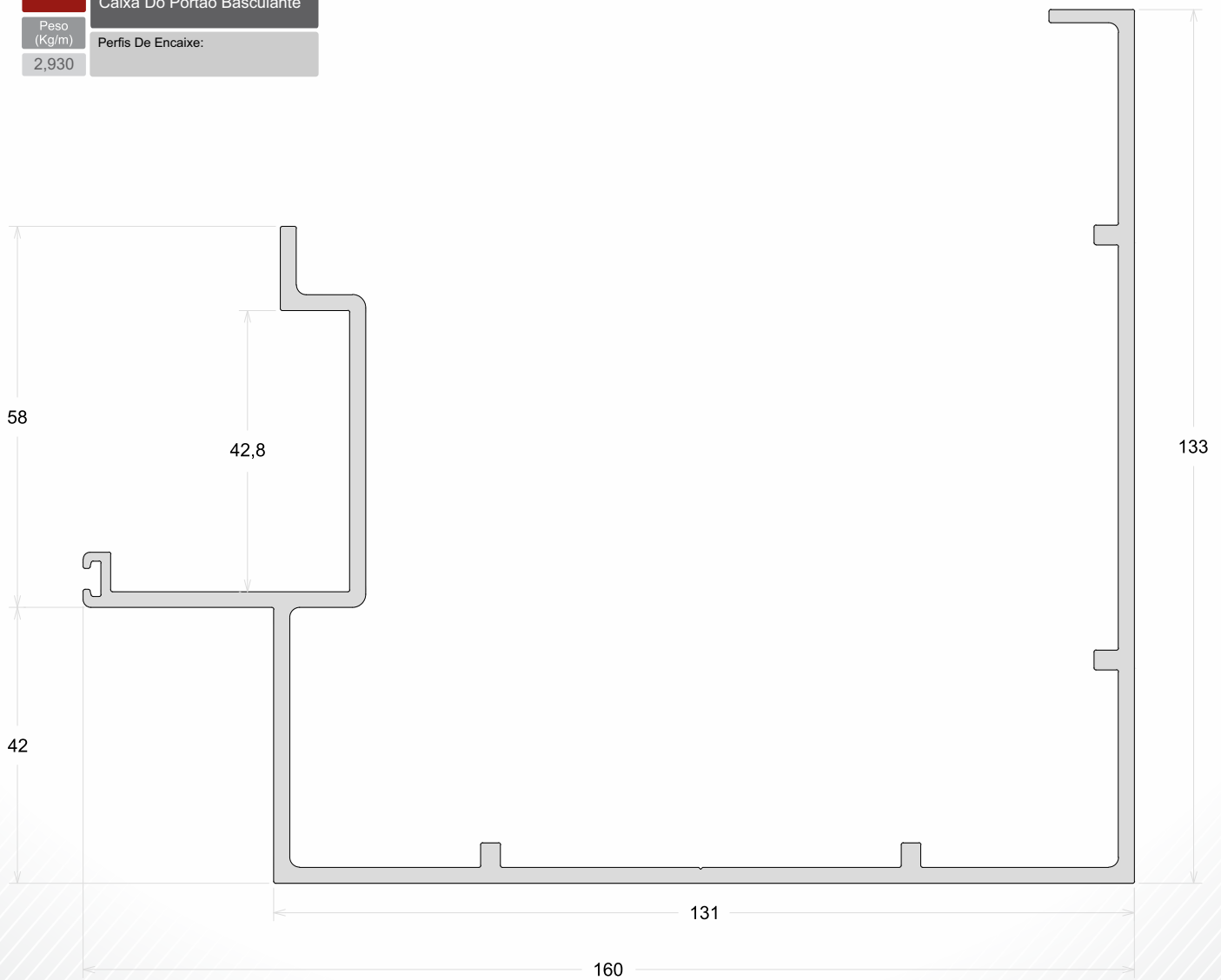

PC-025	Guia Lateral
Peso (Kg/m)	Perfis De Encaixe:
1,298	

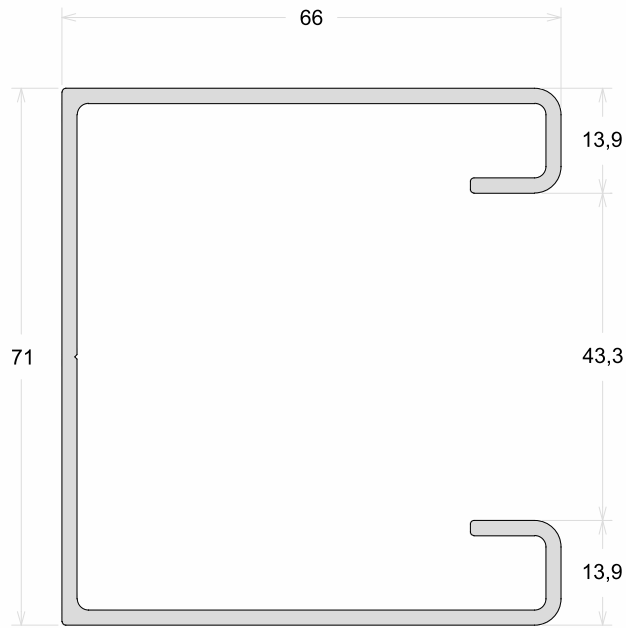

PC-026	Guia Lateral
Peso (Kg/m)	Perfis De Encaixe:
1,371	

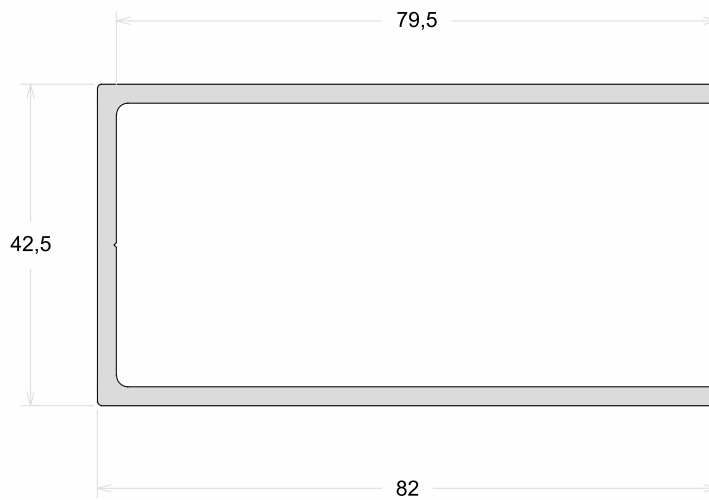

PC-028	Palheta do Portão
Peso (Kg/m)	Perfis De Encaixe:
0,766	

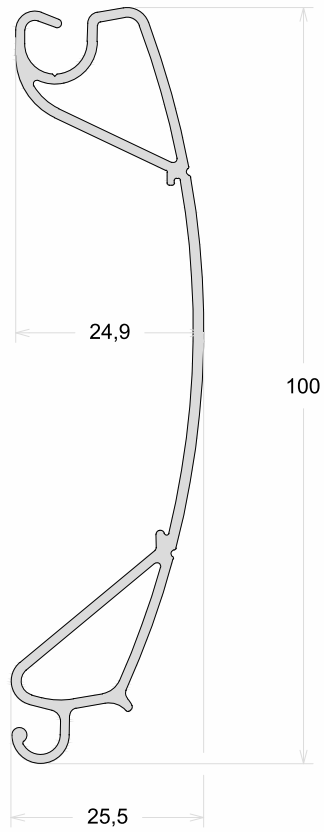

PC-027	Terminal da Palheta
Peso (Kg/m)	Perfis De Encaixe:
0,779	



PUF-001

Guia Do Portão

Peso
(Kg/m)
0,398

Perfis De Encaixe:

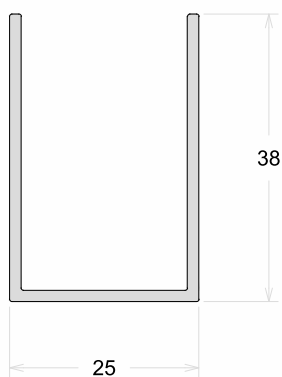

PC-012

Perfil Para Cremalheira

Peso
(Kg/m)
0,158

Perfis De Encaixe:

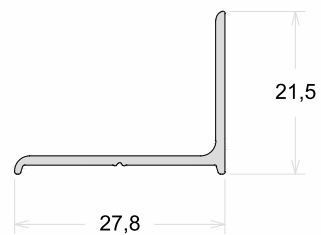

A-058	Quadro Tela Mosquiteira
Peso (Kg/m)	Perfis De Encaixe:
0,200	

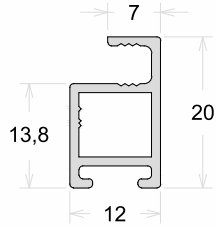

PDV-070	Quadro Tela Mosquiteira
Peso (Kg/m)	Perfis De Encaixe:
0,151	

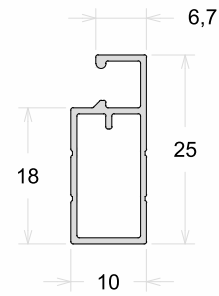

PMQ-001	Quadro Tela Mosquiteira
Peso (Kg/m)	Perfis De Encaixe:
0,277	

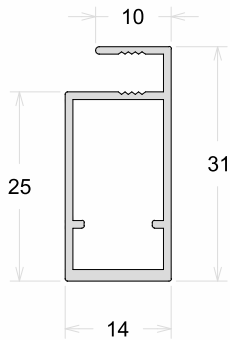

PMQ-002	Quadro Tela Mosquiteira
Peso (Kg/m)	Perfis De Encaixe:
0,345	

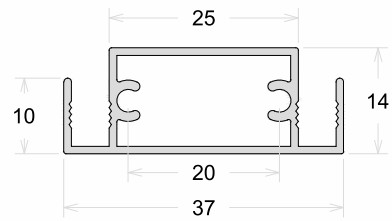

P-227	Quadro Tela Mosquiteira
Peso (Kg/m)	Perfis De Encaixe:
0,462	

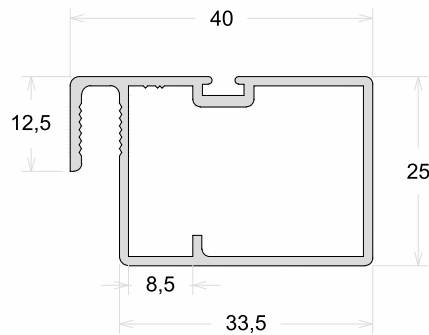

PCB-006	Perfil Lateral - 4mm
Peso (Kg/m)	Perfis De Encaixe:
0,146	

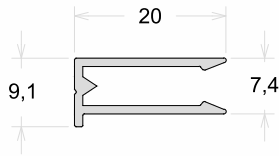

PCB-001	Perfil Lateral - 6mm
Peso (Kg/m)	Perfis De Encaixe:
0,140	

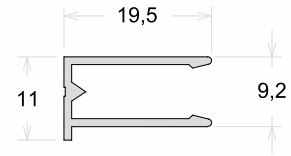

PCB-002	Perfil Lateral - 10mm
Peso (Kg/m)	Perfis De Encaixe:
0,151	

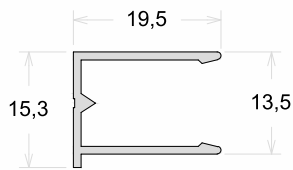

PCB-005	Travessa - 6mm
Peso (Kg/m)	Perfis De Encaixe:
0,378	

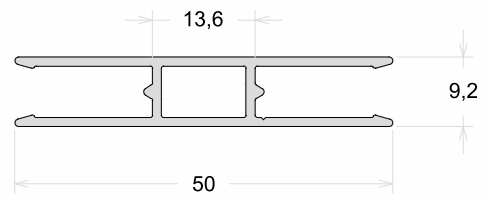

PCB-004	Base Do Fixador
Peso (Kg/m)	Perfis De Encaixe:
0,437	

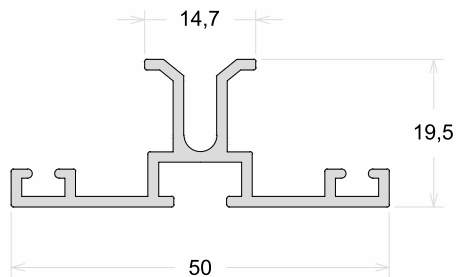

PCB-003	Fixador
Peso (Kg/m)	Perfis De Encaixe:
0,305	

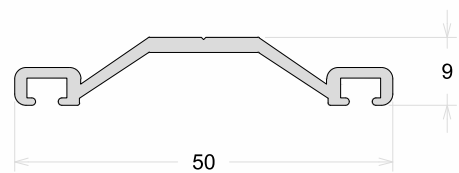

PCB-003L	Fixador
Peso (Kg/m)	Perfis De Encaixe:
0,230	

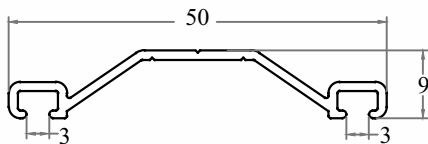

PFC-005L	Fixador
Peso (Kg/m)	Perfis De Encaixe:
0,194	

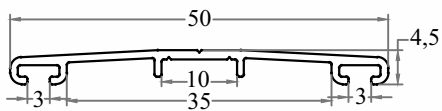

PCB-007	Travessa 10MM
Peso (Kg/m)	Perfis De Encaixe:
0,404	

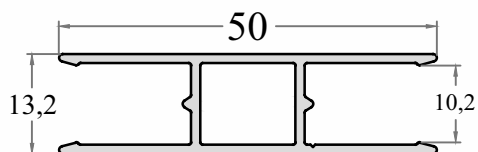

PFG-001	Trilho Superior
Peso (Kg/m)	Perfis De Encaixe:
1,088	

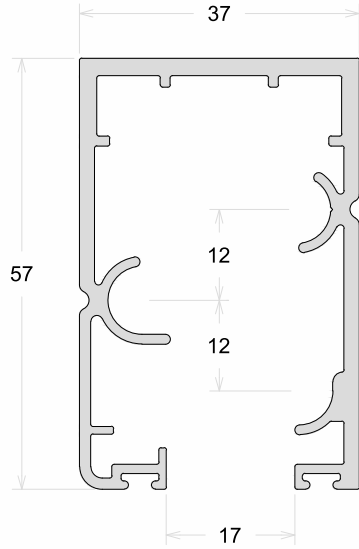

PFG-011	Trilho Superior
Peso (Kg/m)	Perfis De Encaixe:
1,093	

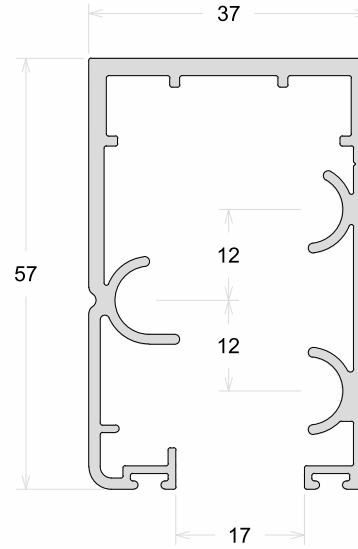

PFG-002	Trilho Inferior
Peso (Kg/m)	Perfis De Encaixe:
0,927	

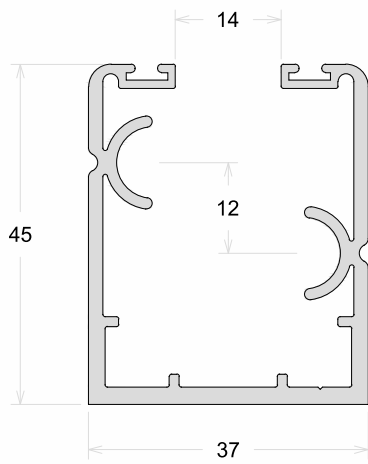

PFG-012	Trilho Inferior
Peso (Kg/m)	Perfis De Encaixe:
1,020	

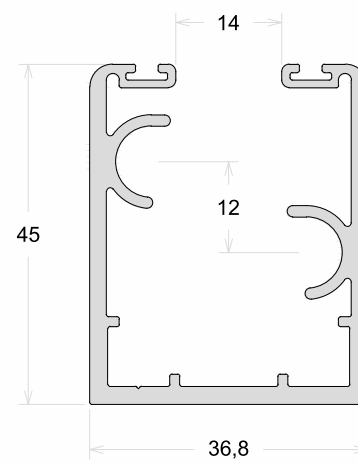

PFG-018	Trilho Superior
Peso (Kg/m)	Perfis De Encaixe:
1,252	

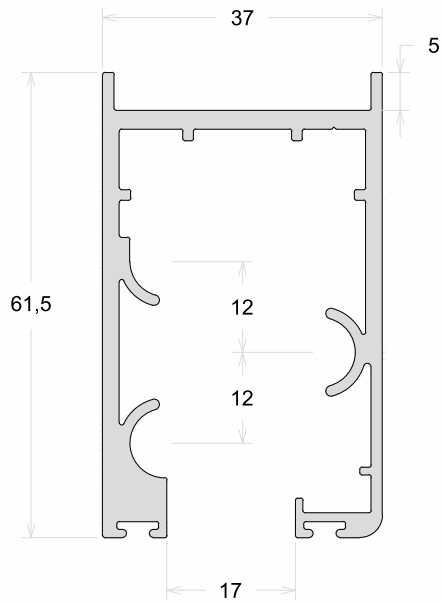

PFG-019	Trilho Inferior
Peso (Kg/m)	Perfis De Encaixe:
1,039	

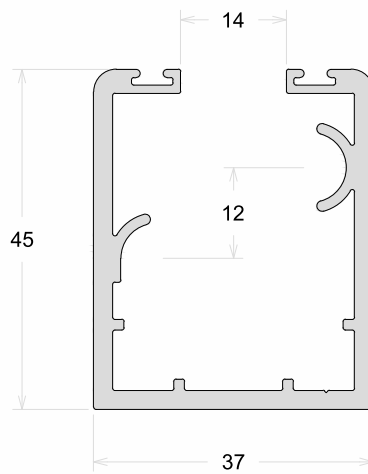

CX-915	Trilho Superior
Peso (Kg/m)	Perfis De Encaixe:
1,296	

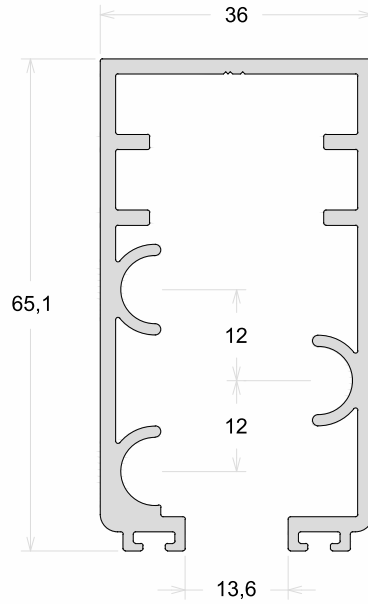

CX-744	Trilho Inferior
Peso (Kg/m)	Perfis De Encaixe:
0,911	

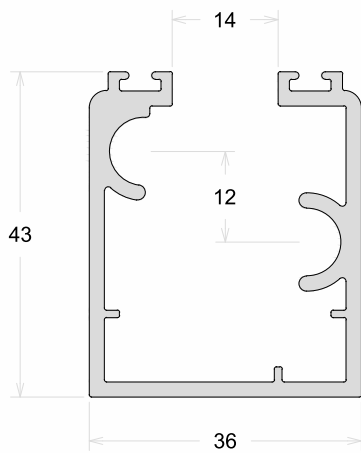

CX-390	Trilho Inferior
Peso (Kg/m)	Perfis De Encaixe:
1,210	

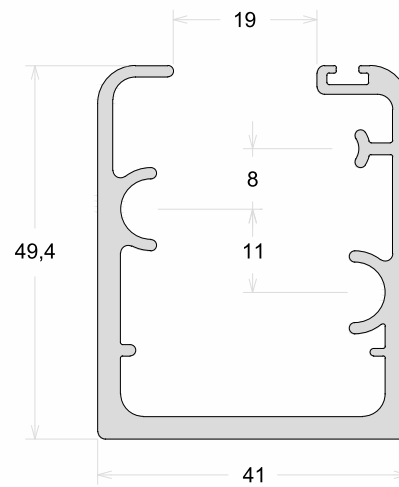

PFG-003	Calha De Ajustes
Peso (Kg/m)	Perfis De Encaixe: PFG-004
0,465	

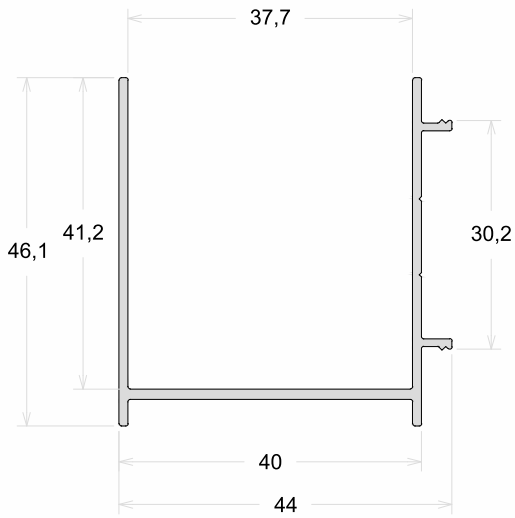

PFG-007	Calha De Ajustes
Peso (Kg/m)	Perfis De Encaixe: PFG-004
,0,466	

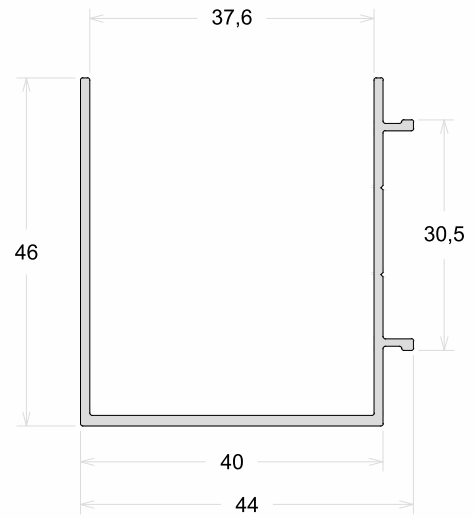

PFG-009	Calha De Ajustes
Peso (Kg/m)	Perfis De Encaixe: PFG-004
0,491	

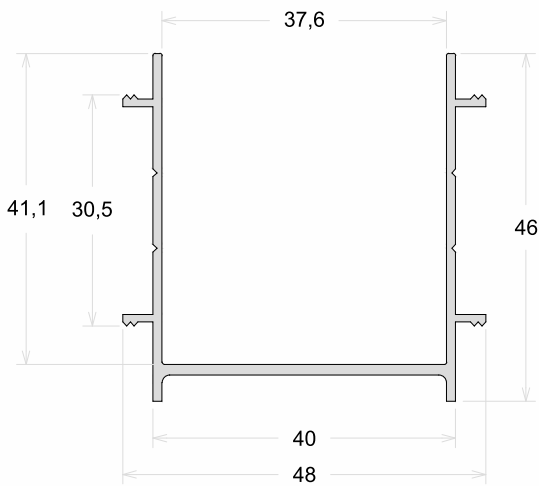

PFG-004	Capa Da Calha De Ajustes
Peso (Kg/m)	Perfis De Encaixe: PFG-003 / PFG-007 / PFG-009
0,149	

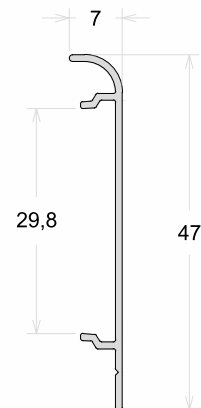

PFG-017	Calha De Ajustes
Peso (Kg/m)	Perfis De Encaixe: PFG-014
0,506	

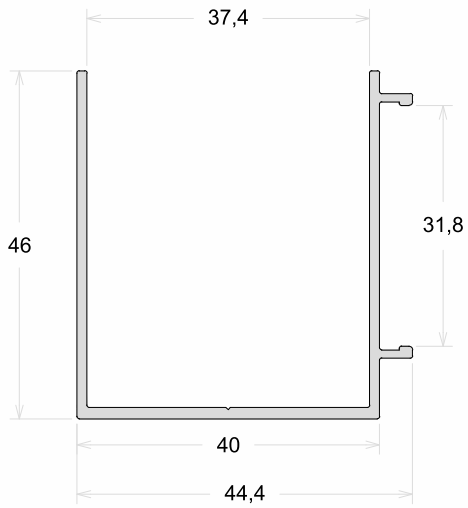

PFG-014	Capa Da Calha De Ajustes
Peso (Kg/m)	Perfis De Encaixe: PFG-017
0,188	

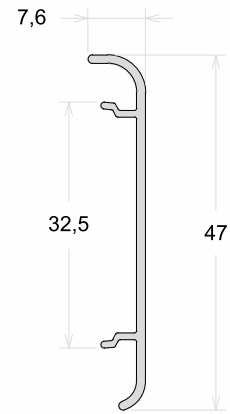

CX-529	Calha De Ajustes
Peso (Kg/m)	Perfis De Encaixe: CX-530
0,664	

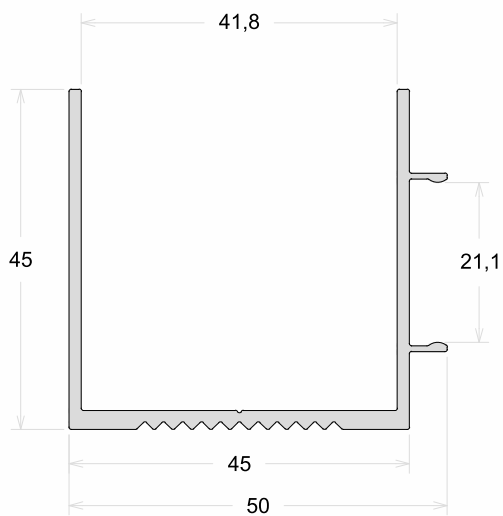

CX-530	Capa Da Calha De Ajustes
Peso (Kg/m)	Perfis De Encaixe: CX-529
0,177	

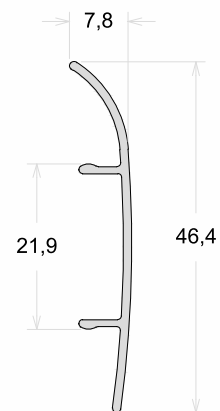

PFG-006	Leito Do Vidro 8mm
Peso (Kg/m)	Perfis De Encaixe:
0,347	

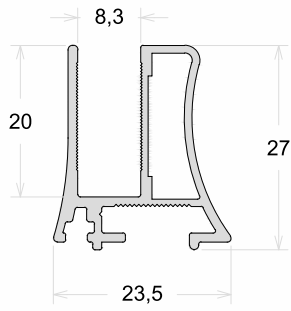

PFG-005	Leito Do Vidro 10mm
Peso (Kg/m)	Perfis De Encaixe:
0,363	

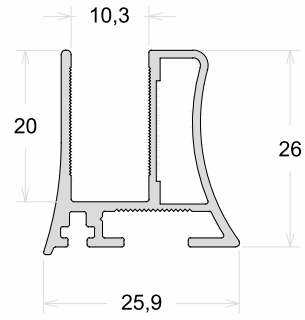

PFG-008	Leito Do Vidro 8mm
Peso (Kg/m)	Perfis De Encaixe:
0,487	

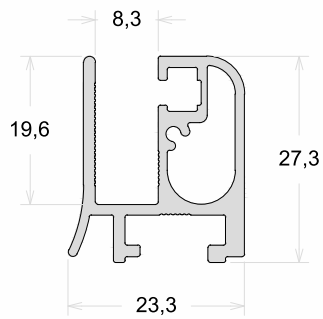

PFG-010	Leito Do Vidro 10mm
Peso (Kg/m)	Perfis De Encaixe:
0,485	

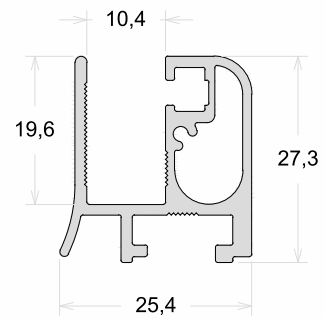

CX-741	Leito Do Vidro 8mm
Peso (Kg/m)	Perfis De Encaixe:
0,387	

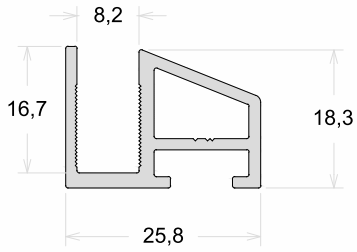

CX-742	Leito Do Vidro 10mm
Peso (Kg/m)	Perfis De Encaixe:
0,398	

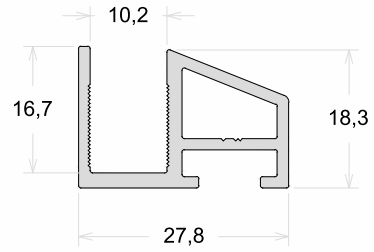

CX-401	Leito Do Vidro 8mm
Peso (Kg/m)	Perfis De Encaixe:
0,353	

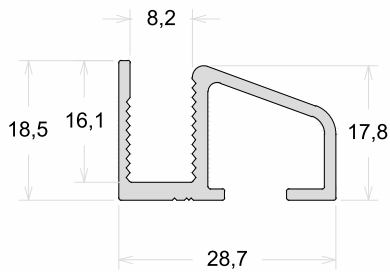

CX-400	Leito Do Vidro 10mm
Peso (Kg/m)	Perfis De Encaixe:
0,500	

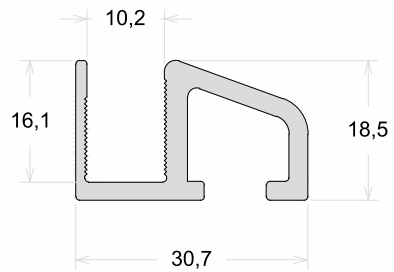

PEI-007	Trilho Superior
Peso (Kg/m)	Perfis De Encaixe:
1,313	

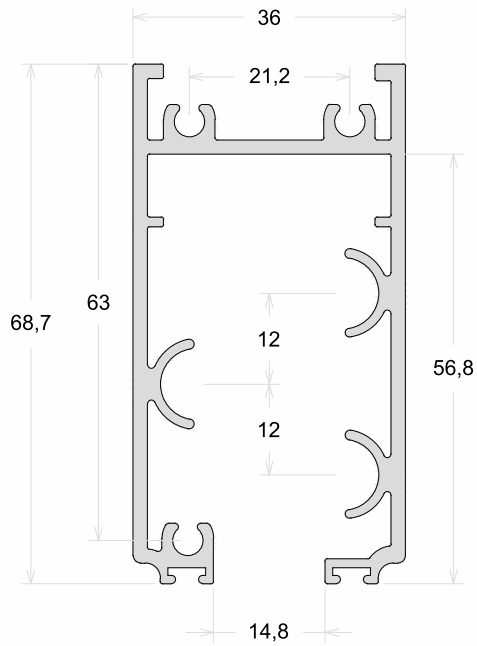

CX-745	Complemento De Saída
Peso (Kg/m)	Perfis De Encaixe:
0,374	

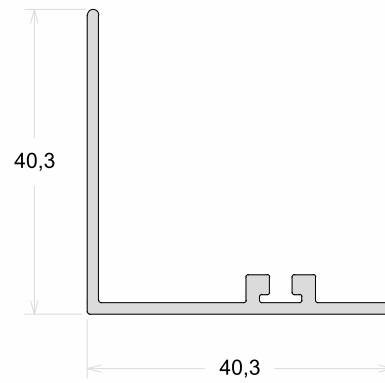

CX-740	Calha De Ajustes
Peso (Kg/m)	Perfis De Encaixe:
0,602	

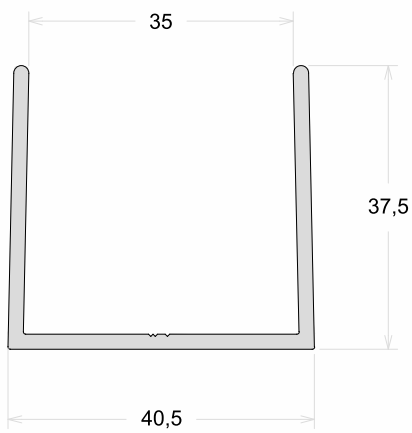

CX-391	Calha De Ajustes
Peso (Kg/m)	Perfis De Encaixe:
0,496	

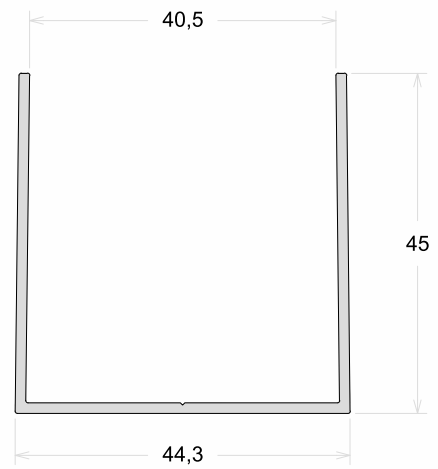

CG-081

Click do Gradil

Peso
(Kg/m)

0,173

Perfis De Encaixe:
CG-079

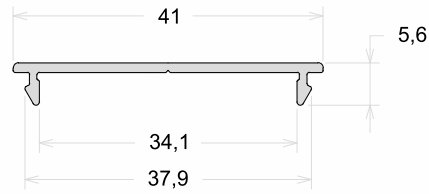

CG-003	Corrimão
Peso (Kg/m)	Perfis De Encaixe: PAC-003
0,423	

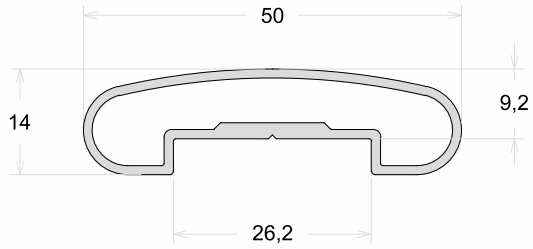

CG-500	Corrimão
Peso (Kg/m)	Perfis De Encaixe: PAC-003
0,654	

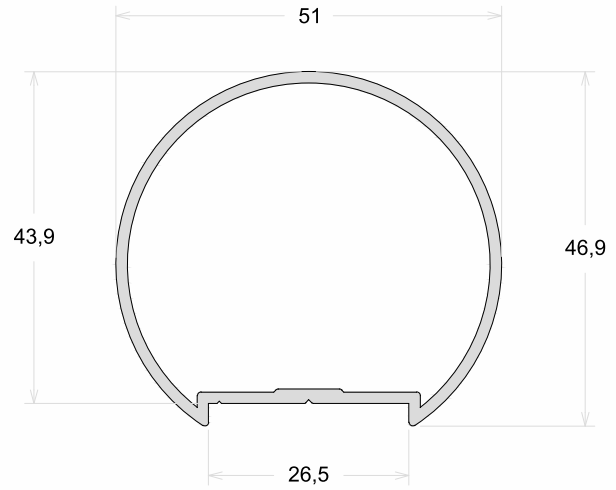

PAC-003	Suporte Do Corrimão
Peso (Kg/m)	Perfis De Encaixe: CG-003 / CG-500
2,206	

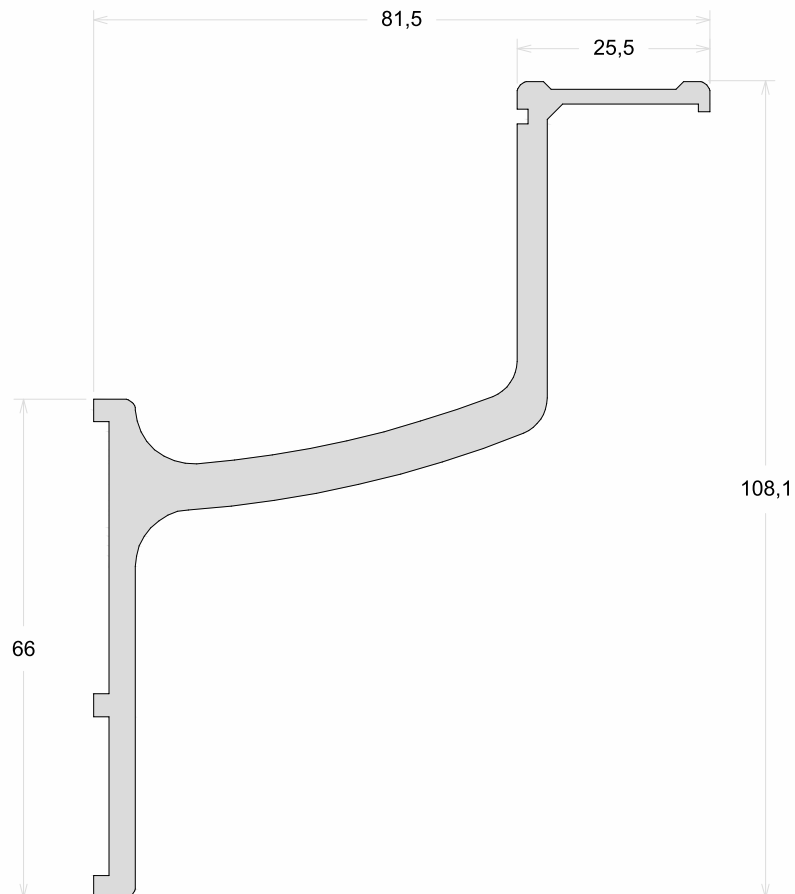

TR-070	Tubo Redondo 38mm
Peso (Kg/m)	Perfis De Encaixe: PAC-005
0,407	

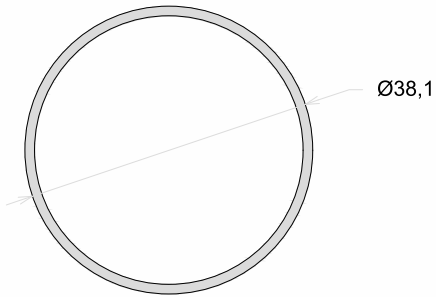

TR-073	Tubo Redondo 38mm
Peso (Kg/m)	Perfis De Encaixe: PAC-005
0,558	

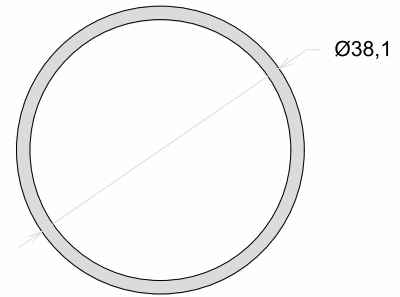

PAC-005	Suporte Do Corrimão
Peso (Kg/m)	Perfis De Encaixe: TR-070 / TR-073
2,389	

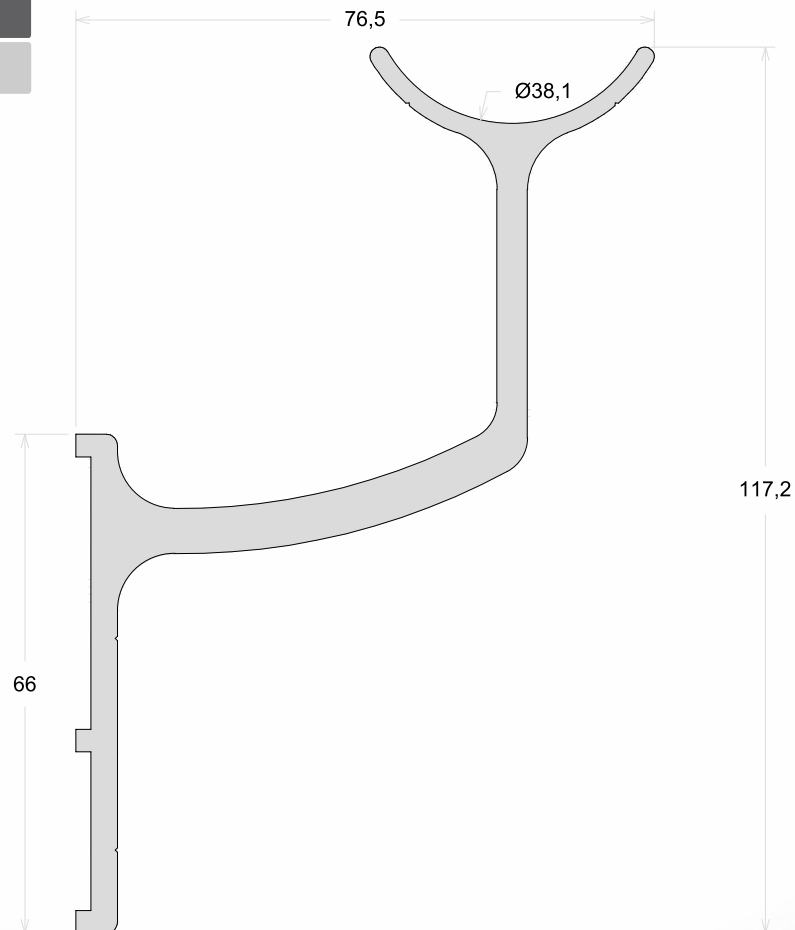

CM-1002	Contramarco
Peso (Kg/m)	Perfis De Encaixe:
0,263	

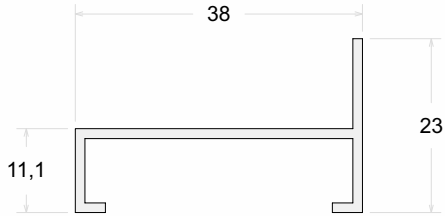

CM-060	Contramarco
Peso (Kg/m)	Perfis De Encaixe:
0,222	

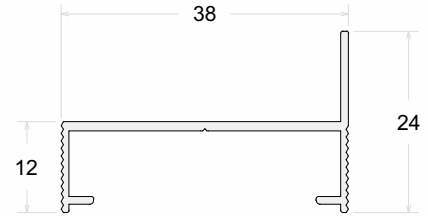

Y-1174	Contramarco
Peso (Kg/m)	Perfis De Encaixe:
0,369	

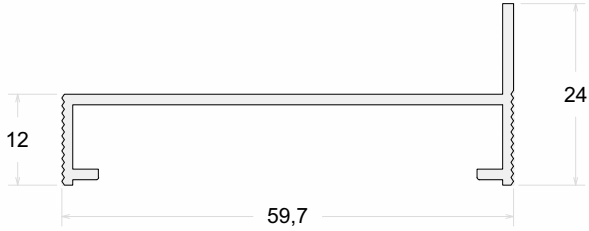

CM-063	Contramarco
Peso (Kg/m)	Perfis De Encaixe:
0,154	

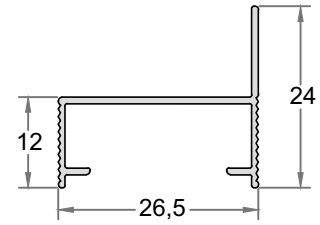

CM-175	Chumbador do Contramarco
Peso (Kg/m)	Perfis De Encaixe:
0,589	

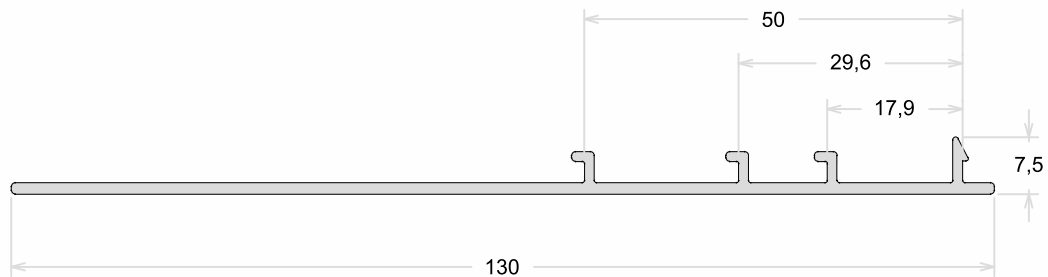

Medida de uso 20 mm

MP-348	Arremate / Vista Interna
Peso (Kg/m)	Perfis De Encaixe:
0,174	

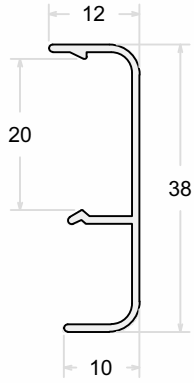

MN-014	Arremate / Vista Interna
Peso (Kg/m)	Perfis De Encaixe:
0,201	

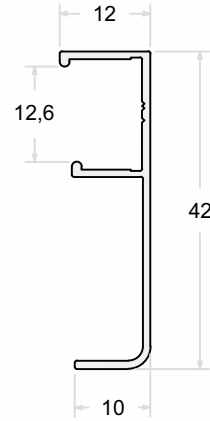

MP-347	Arremate / Vista Interna
Peso (Kg/m)	Perfis De Encaixe:
0,162	

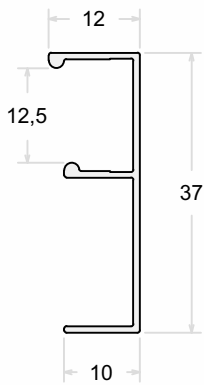

MP-347S	Arremate / Vista Interna
Peso (Kg/m)	Perfis De Encaixe:
0,217	

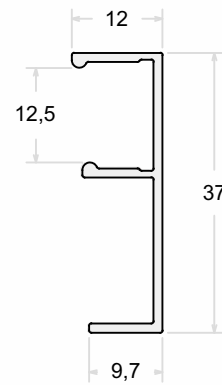

MP-3348	Arremate / Vista Interna
Peso (Kg/m)	Perfis De Encaixe:
0,206	

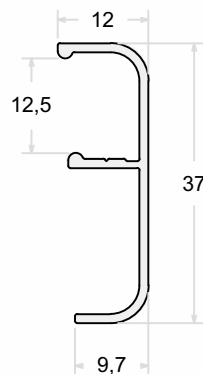

MP-350	Arremate / Vista Interna
Peso (Kg/m)	Perfis De Encaixe:
0,268	

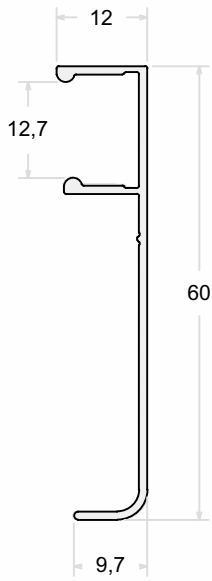

PEX-002	Arremate / Rodapé
Peso (Kg/m)	Perfis De Encaixe:
0,332	

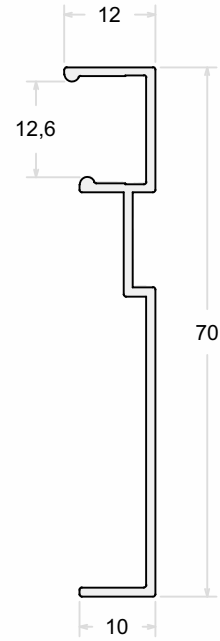

MP-346	Arremate / Vista Interna
Peso (Kg/m)	Perfis De Encaixe:
0,302	

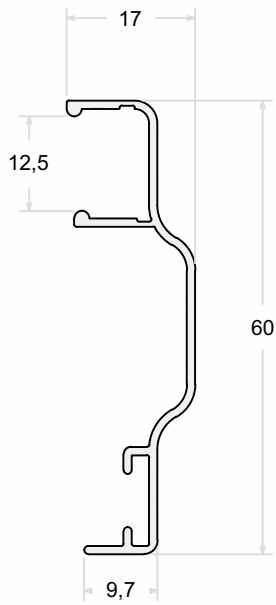

MP-349	Arremate / Vista Interna
Peso (Kg/m)	Perfis De Encaixe:
0,298	

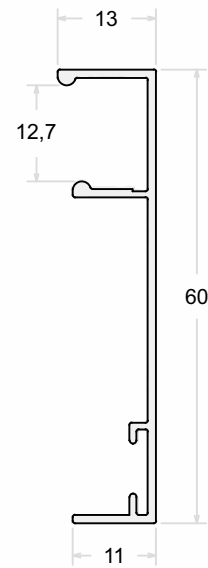

25-540	Marco Porta de Giro
Peso (Kg/m)	Perfis De Encaixe:
0,440	

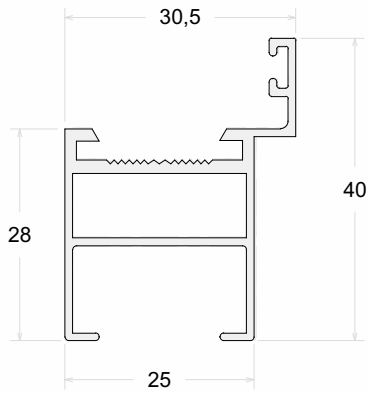

25-059	Marco Porta de Giro
Peso (Kg/m)	Perfis De Encaixe:
0,390	

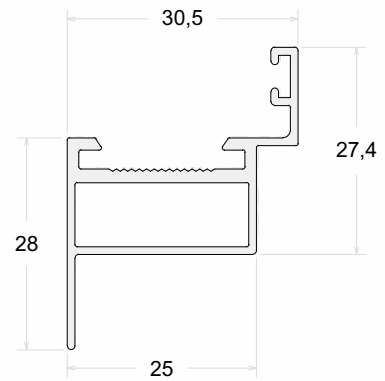

25-542	Folha Perimetral
Peso (Kg/m)	Perfis De Encaixe: BG-001
0,542	

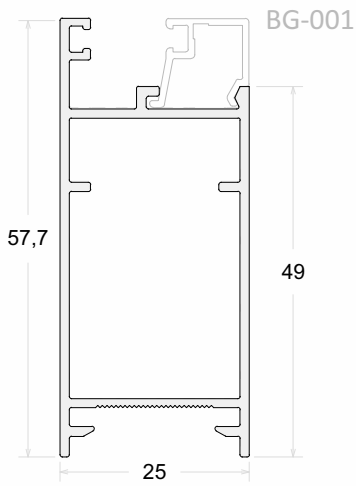

25-544	Folha Perimetral - Veneziana
Peso (Kg/m)	Perfis De Encaixe:
0,597	

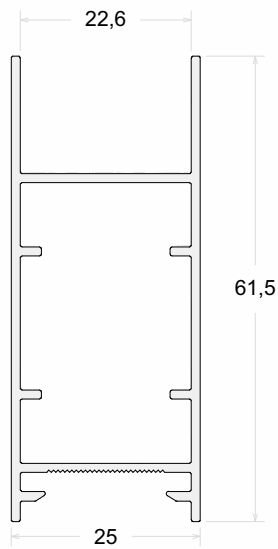

25-543	Folha Perimetral
Peso (Kg/m)	Perfis De Encaixe: BG-001
0,728	

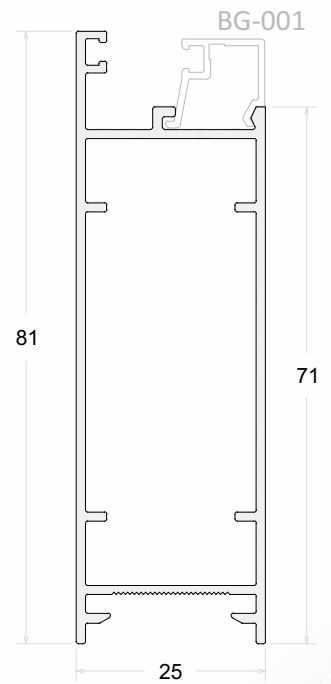

25-026	Travessa 40 mm
Peso (Kg/m)	Perfis De Encaixe:
0,474	

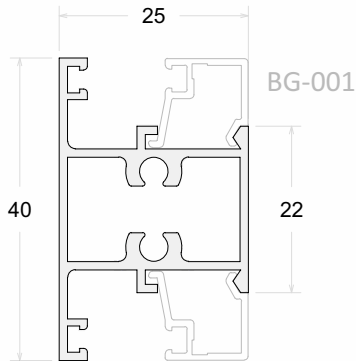

25-508	Travessa 56 mm
Peso (Kg/m)	Perfis De Encaixe:
0,594	

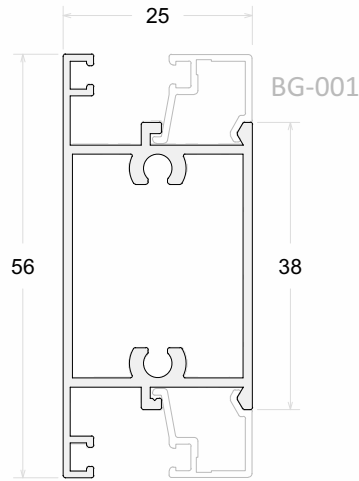

P-153	Travessa 40 mm
Peso (Kg/m)	Perfis De Encaixe:
0,529	

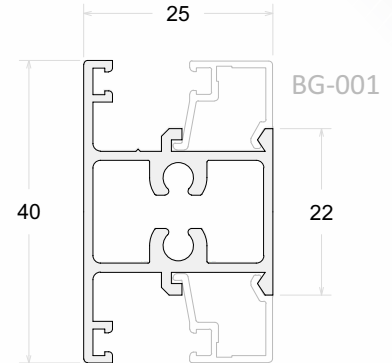

DS-036	Porta Veneziana
Peso (Kg/m)	Perfis De Encaixe:
0,152	

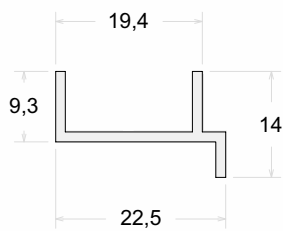

BG-001	Baguete Vertical e Horizontal
Peso (Kg/m)	Perfis De Encaixe:
0,091	

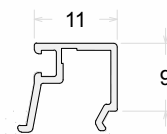

PSU-203	Baguete
Peso (Kg/m)	Perfis De Encaixe:
0,135	

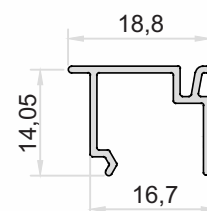

PSU-279	Marco Porta de Giro
Peso (Kg/m)	Perfis De Encaixe:
0,507	

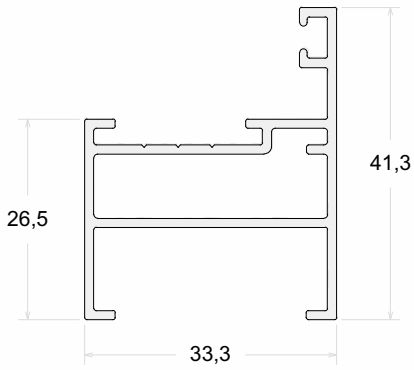

25-548	Batente Porta de Giro
Peso (Kg/m)	Perfis De Encaixe:
0,221	

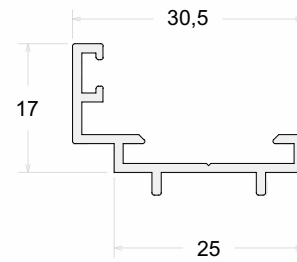

PSU-110	Folha Superior e Inferior
Peso (Kg/m)	Perfis De Encaixe:
0,514	

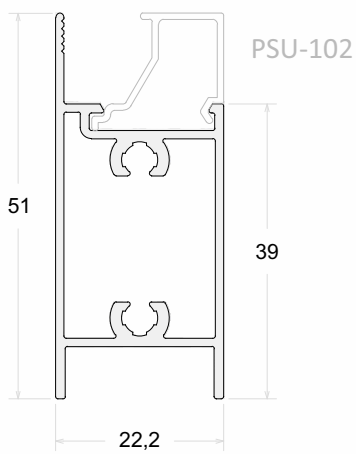

PSU-111	Folha Porta de Giro
Peso (Kg/m)	Perfis De Encaixe:
0,563	

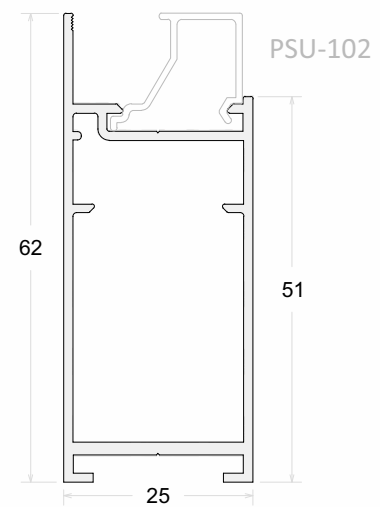

PSU-241	Folha Perimetral Sem Baguele
Peso (Kg/m)	Perfis De Encaixe:
0,690	

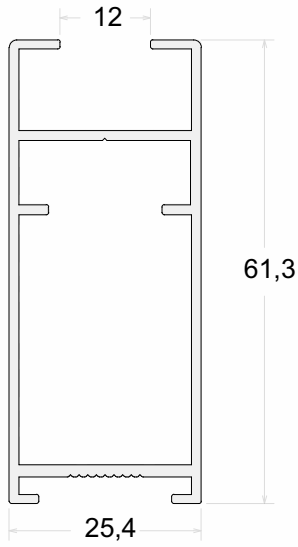

PSU-350	Folha Perimetral - Lambri
Peso (Kg/m)	Perfis De Encaixe:
0,768	

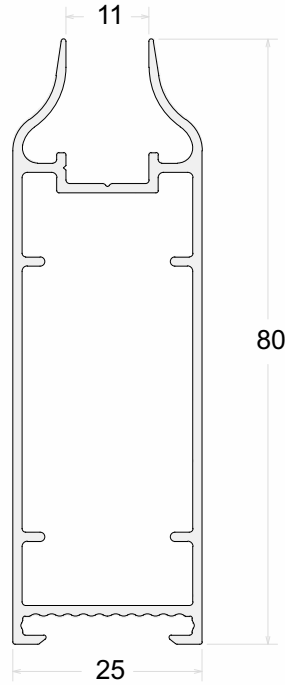

PSU-450	Montante 100mm Porta de Giro
Peso (Kg/m)	Perfis De Encaixe:
0,950	

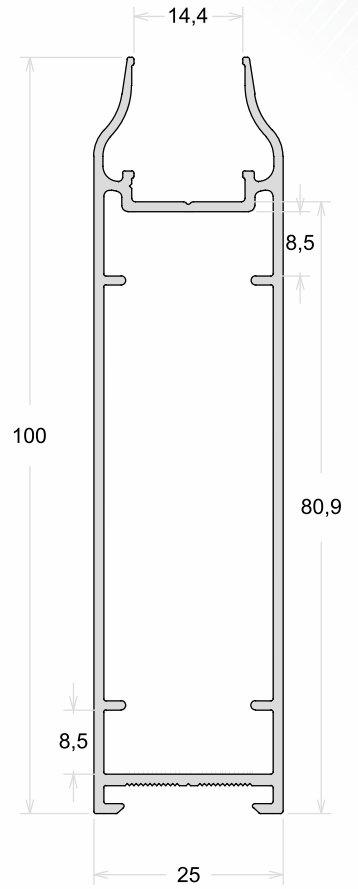

PSU-225	Folha Horizontal
Peso (Kg/m)	Perfis De Encaixe:
0,966	

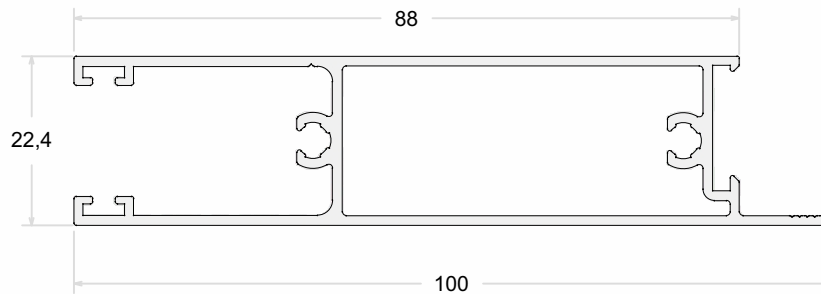

PEI-009	Marco Vertical e Horizontal
Peso (Kg/m)	Perfis De Encaixe:
0,315	

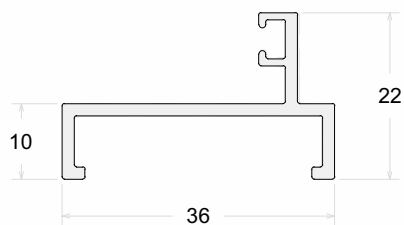

PEI-013	Marco Vertical e Horizontal
Peso (Kg/m)	Perfis De Encaixe:
0,897	

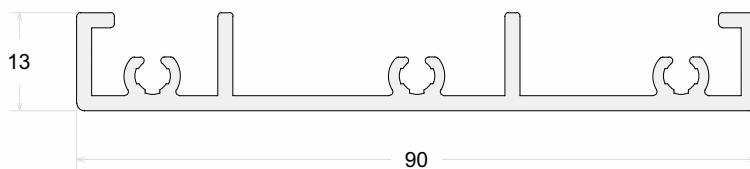

PEI-012	Marco Vertical e Horizontal
Peso (Kg/m)	Perfis De Encaixe:
0,830	

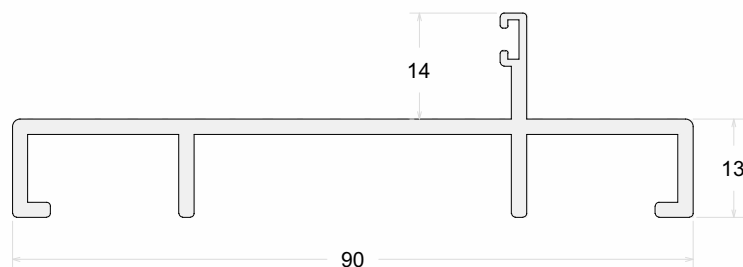

30-023 Marco Porta de Giro
Peso (Kg/m) 0,526
Perfis De Encaixe:

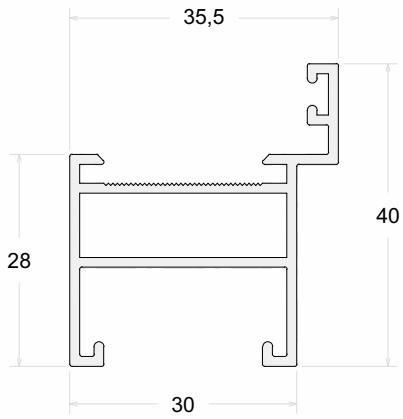

30-035 Marco Porta de Giro
Peso (Kg/m) 0,949
Perfis De Encaixe:

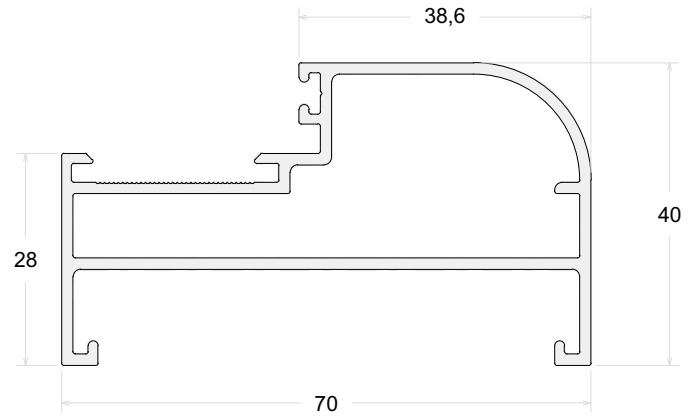

P-272 Marco Porta de Giro
Peso (Kg/m) 0,751
Perfis De Encaixe:

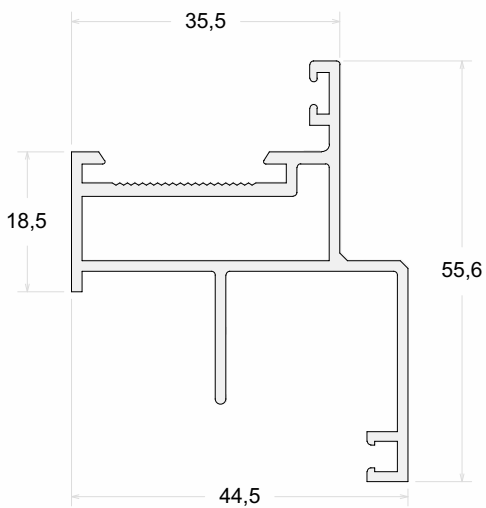

30-034 Batente Porta de Giro
Peso (Kg/m) 0,261
Perfis De Encaixe:

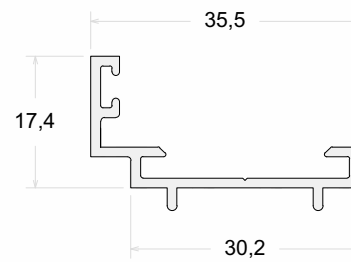

PEI-011	Folha Perimatral
Peso (Kg/m)	Perfis De Encaixe:
1,116	

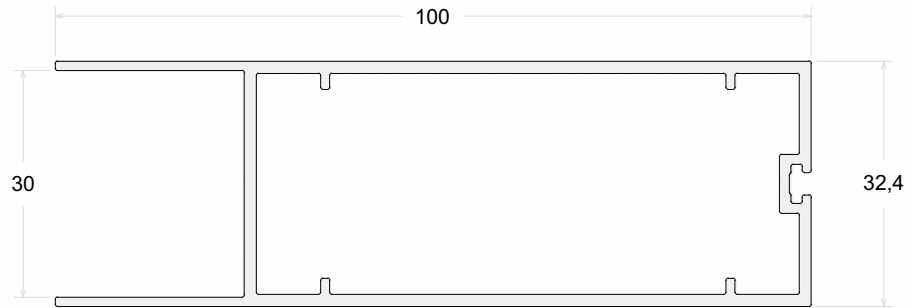

PPO-007	Folha Perimetral
Peso (Kg/m)	Perfis De Encaixe:
1,097	

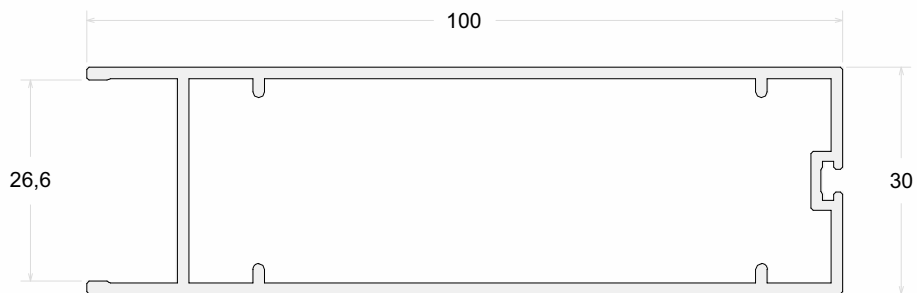

PPO-002	Marco Vertical e Horizontal
Peso (Kg/m)	Perfis De Encaixe:
1,088	

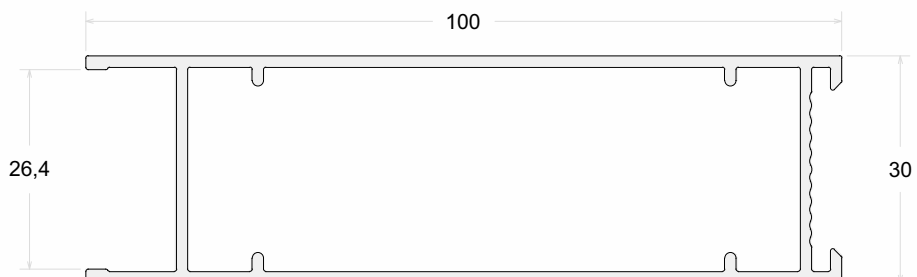

PPO-005	Folha Perimetral
Peso (Kg/m)	Perfis De Encaixe:
0,714	

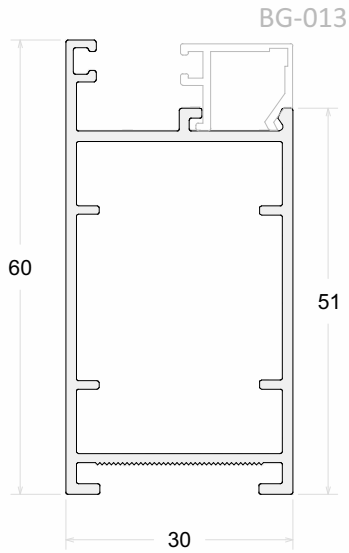

A-144	Folha Perimetral
Peso (Kg/m)	Perfis De Encaixe:
0,766	

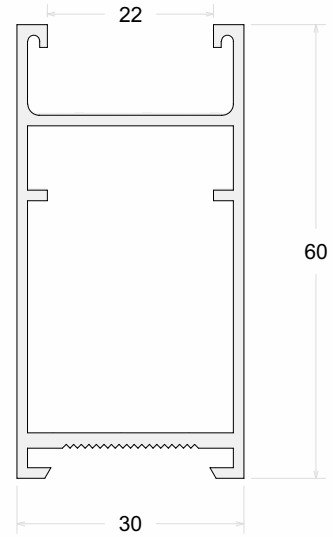

PPO-003	Folha Perimetral
Peso (Kg/m)	Perfis De Encaixe:
1,125	

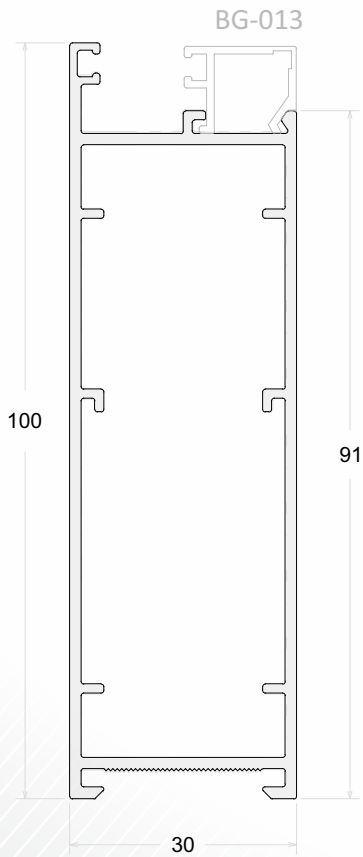

P-264	Folha Perimetral
Peso (Kg/m)	Perfis De Encaixe:
1,124	

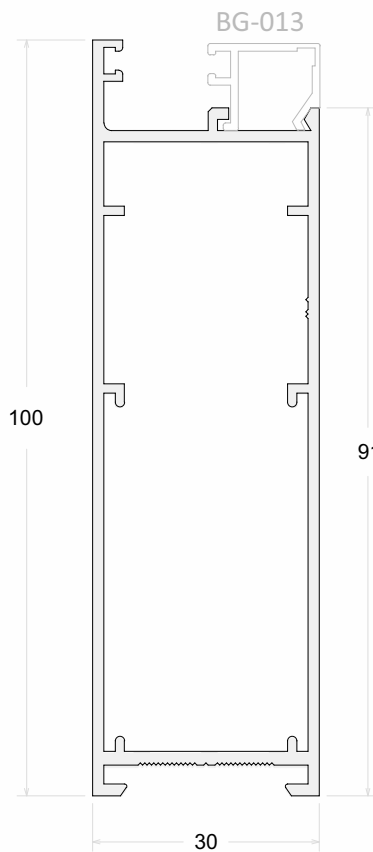

30-040	Montante 100mm Porta de Giro
Peso (Kg/m)	Perfis De Encaixe:
1,010	

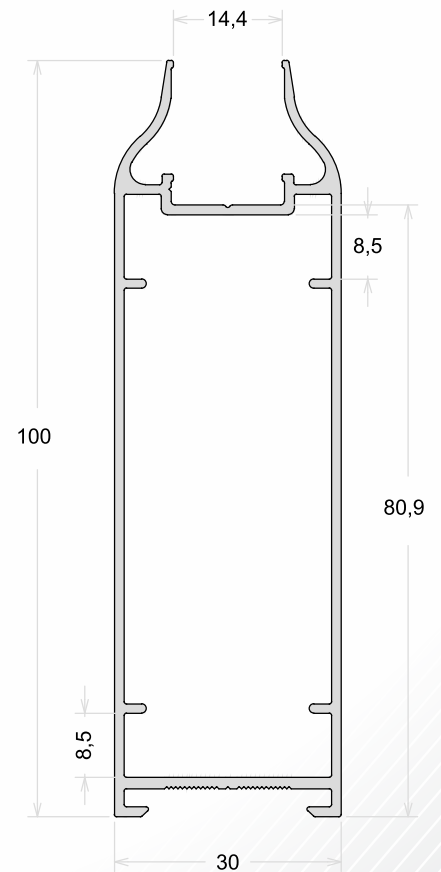

ME-075	Folha Perimetral
Peso (Kg/m)	Perfis De Encaixe:
0,978	

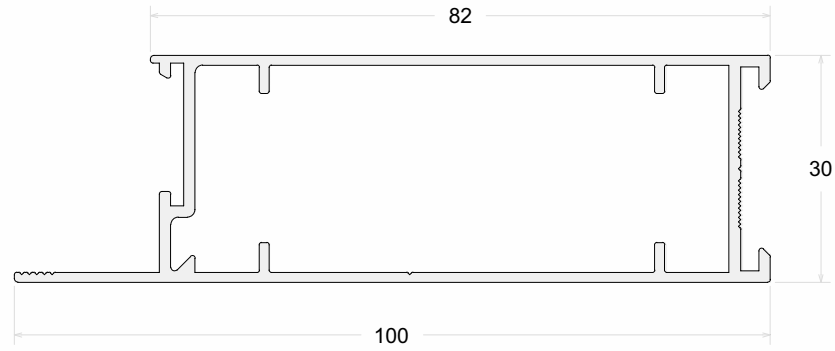

PPO-004	Travessa 75 mm
Peso (Kg/m)	Perfis De Encaixe:
0,807	

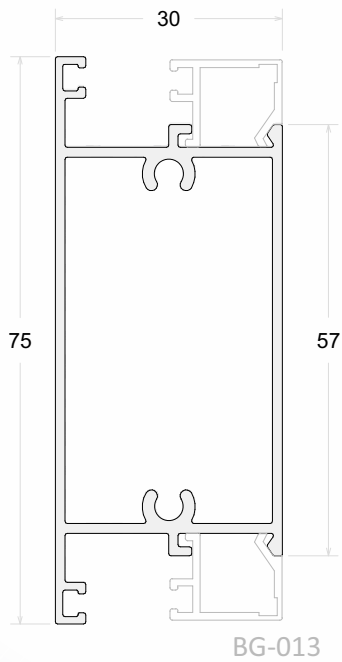

BG-013	Baguete Vertical e Horizontal
Peso (Kg/m)	Perfis De Encaixe:
0,110	

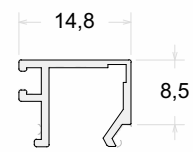

PEI-010	Lambri
Peso (Kg/m)	Perfis De Encaixe:
1,315	

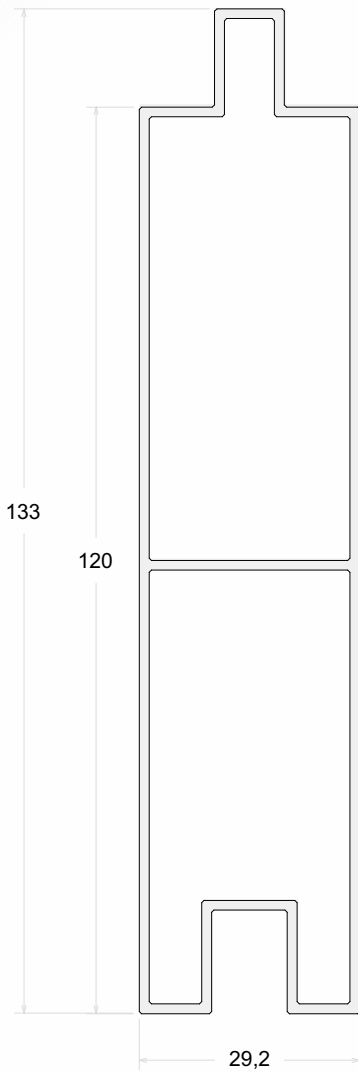

PPO-001	Lambri
Peso (Kg/m)	Perfis De Encaixe:
1,612	

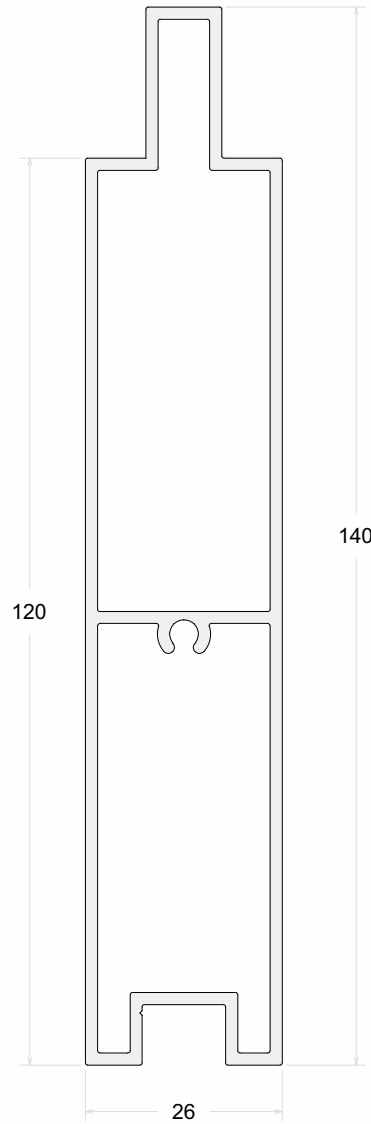

PPO-006	Lambri
Peso (Kg/m)	Perfis De Encaixe:
1,612	

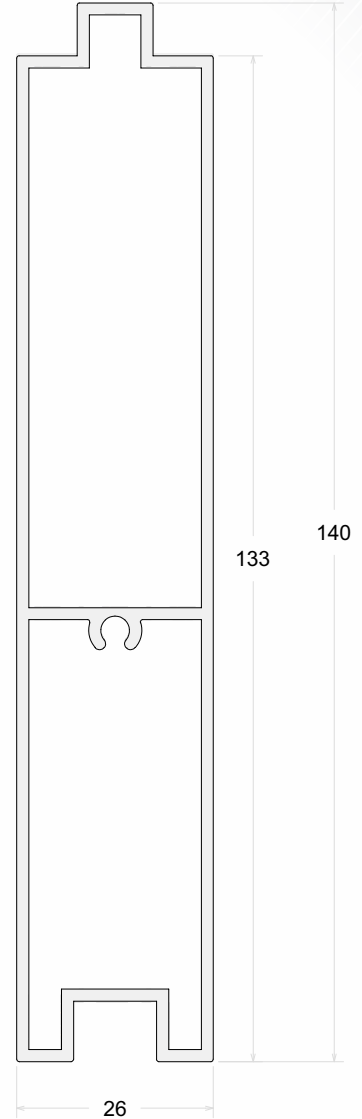

PEI-014	Friso Lambri
Peso (Kg/m)	Perfis De Encaixe:
0,495	

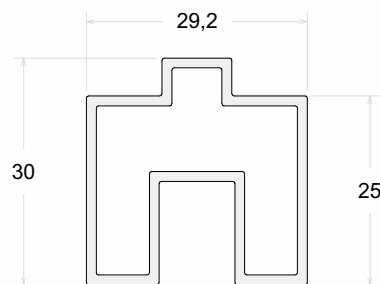

PLG-056	Marco Porta de Giro
Peso (Kg/m)	Perfis De Encaixe:
0,588	

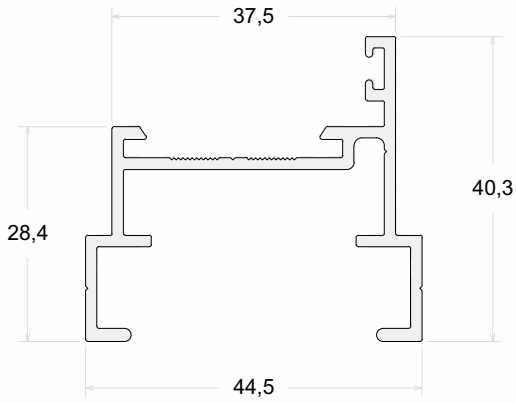

PLG-043	Folha Perimetral
Peso (Kg/m)	Perfis De Encaixe:
0,877	

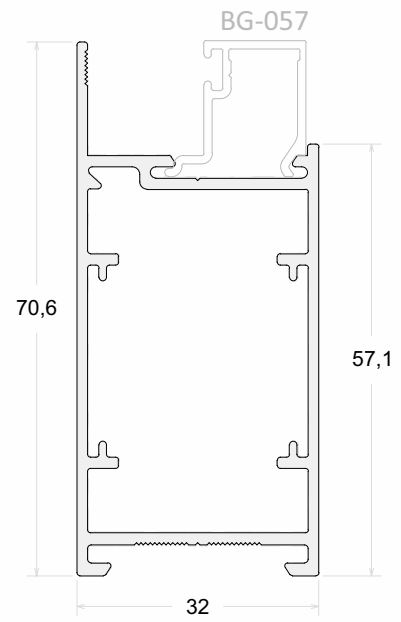

PLG-239	Folha Perimetral
Peso (Kg/m)	Perfis De Encaixe:
1,121	

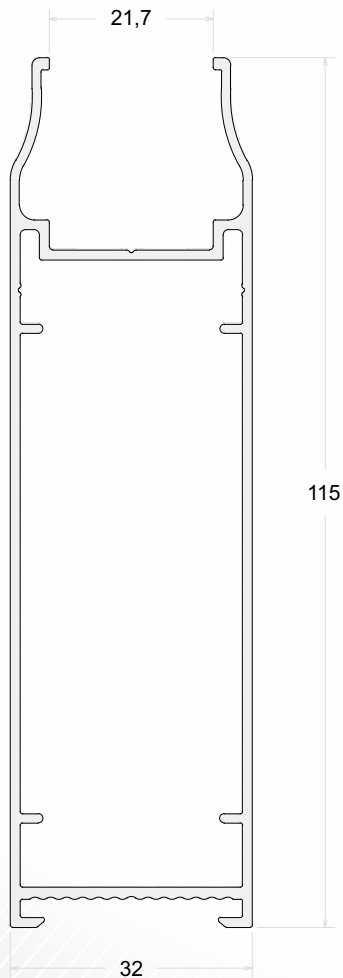

PLG-042	Folha Perimetral
Peso (Kg/m)	Perfis De Encaixe:
1,104	

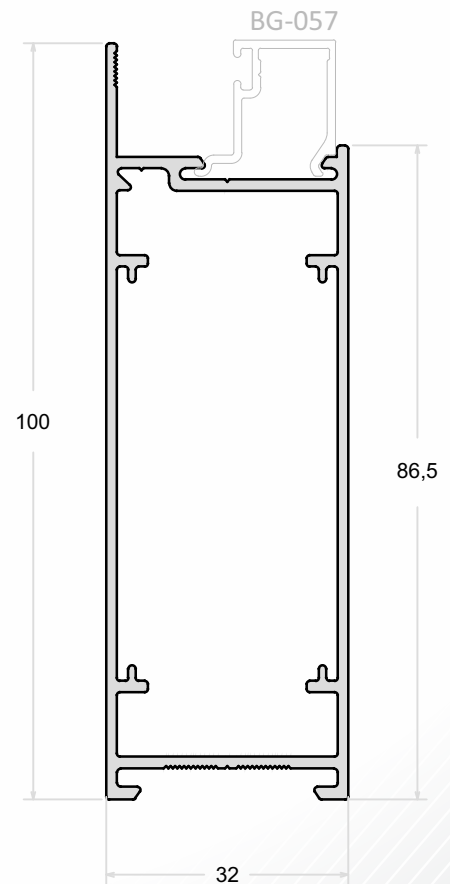

PLG-238	Redutor
Peso (Kg/m)	Perfis De Encaixe
0,273	

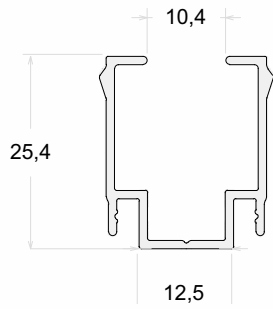

PLG-016	Batente Porta De Giro
Peso (Kg/m)	Perfis De Encaixe:
0,316	

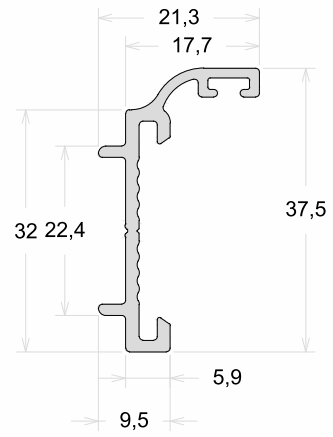

PLG-055	Travessa 64 mm
Peso (Kg/m)	Perfis De Encaixe:
0,706	

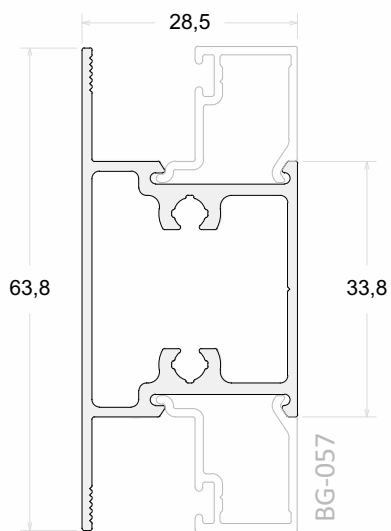

DV-013	Acabamento Ripado
Peso (Kg/m)	Perfis De Encaixe:
0,318	

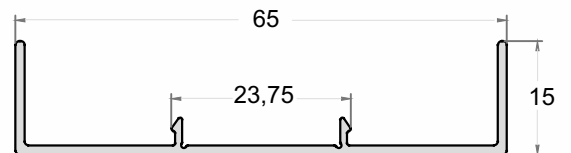

BG-057	Baguete Vertical e Horizontal
Peso (Kg/m)	Perfis De Encaixe:
0,170	

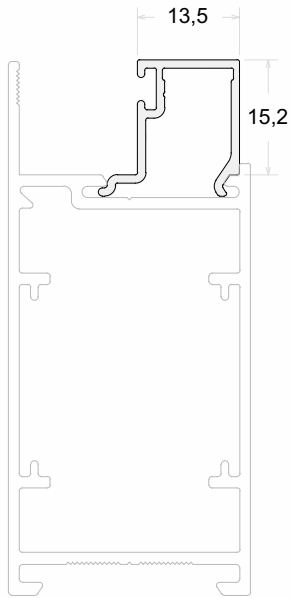

PLG-059	Baguete Vertical e Horizontal
Peso (Kg/m)	Perfis De Encaixe:
0,157	

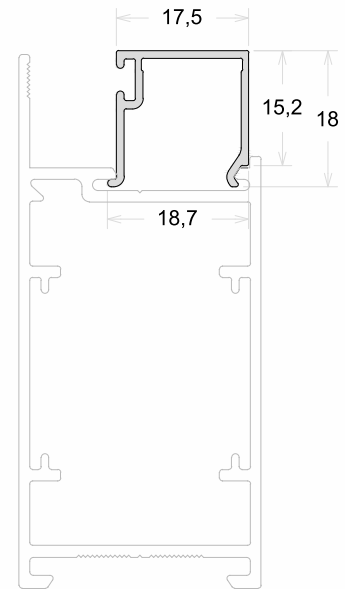

PLG-055	Travessa 64 mm
Peso (Kg/m)	Perfis De Encaixe:
0,706	

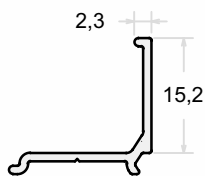

PLG-027	Baguete Veneziana
Peso (Kg/m)	Perfis De Encaixe:
0,146	

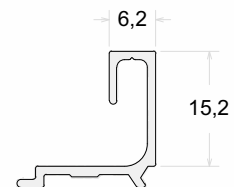

PSU-102	Baguete Vertical e Horizontal
Peso (Kg/m)	Perfis De Encaixe:
0,105	

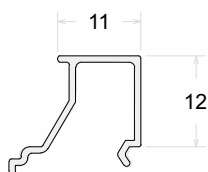

PSU-108	Complemento Veneziana
Peso (Kg/m)	Perfis De Encaixe:
0,140	

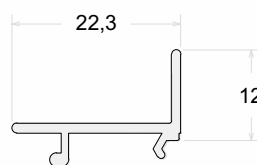

PSU-104	Baguete Vertical e Horizontal
Peso (Kg/m)	Perfis De Encaixe:
0,109	

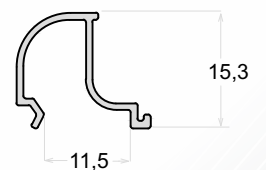

PPO-008	Marco Regulavel Linha 32
Peso (Kg/m)	Perfis De Encaixe:
1,031	

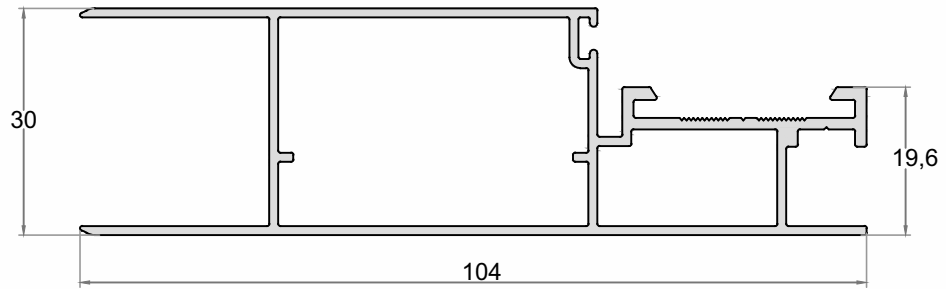

PPO-010	Arremate
Peso (Kg/m)	Perfis De Encaixe:
0,755	

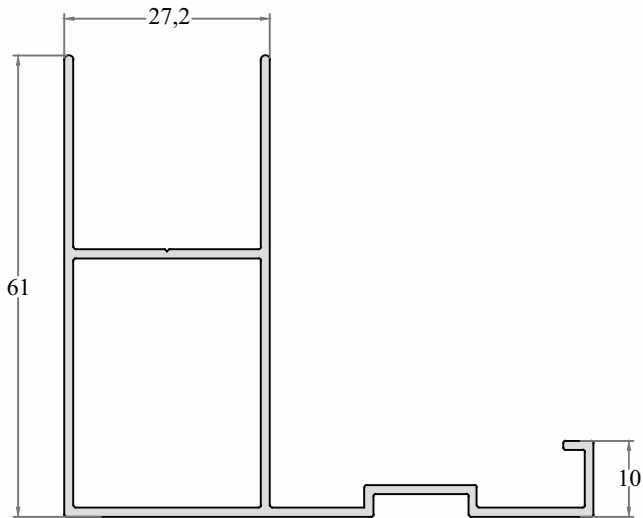

PPO-012	Arremate
Peso (Kg/m)	Perfis De Encaixe:
0,407	

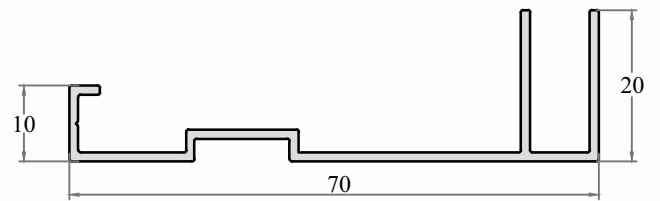

PPO-011	Prolongador
Peso (Kg/m)	Perfis De Encaixe:
0,381	

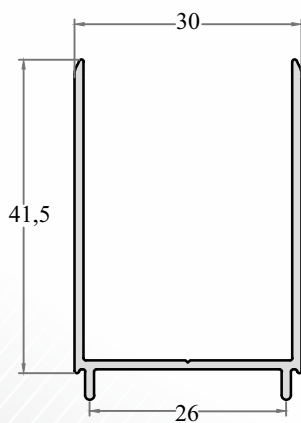

PPO-009	Marco Regulavel Linha 25
Peso (Kg/m)	Perfis De Encaixe:
1,008	

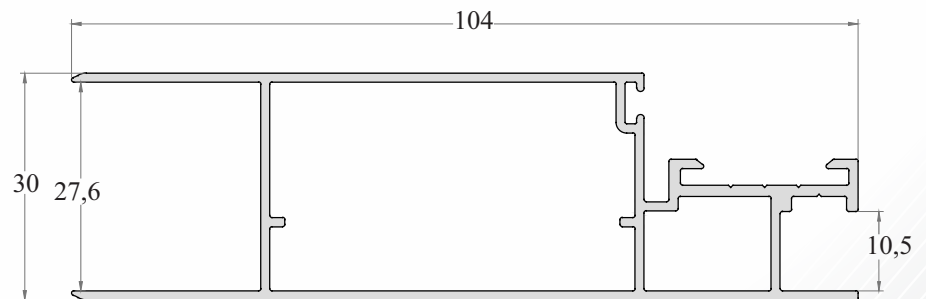

P-280	Marco
Peso (Kg/m)	Perfis De Encaixe:
0,816	

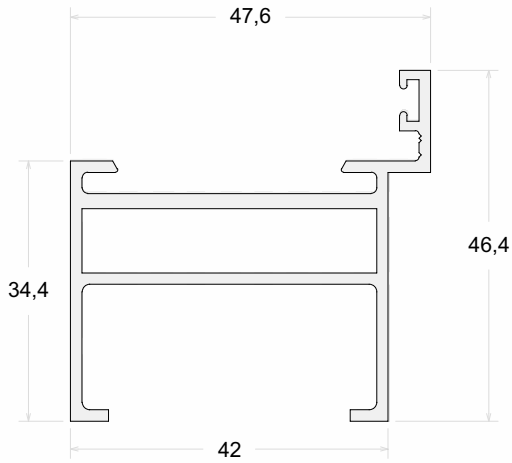

42-040	Batente Marco
Peso (Kg/m)	Perfis De Encaixe:
0,621	

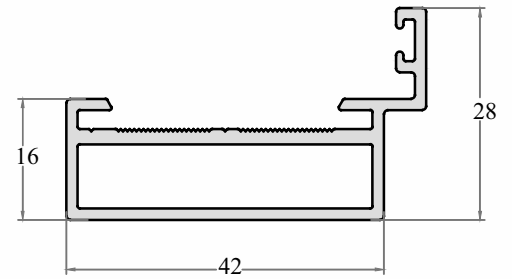

42-014	Batente
Peso (Kg/m)	Perfis De Encaixe:
0,374	

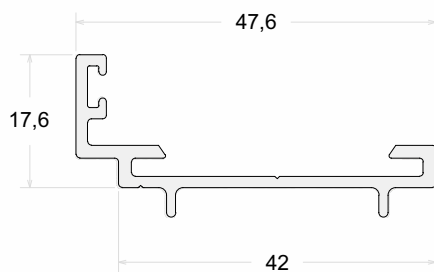

42-048	Click de Acabamento da Folha
Peso (Kg/m)	Perfis De Encaixe:
0,344	

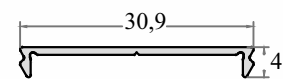

42-050	Folha da Porta
Peso (Kg/m)	Perfis De Encaixe:
2,052	

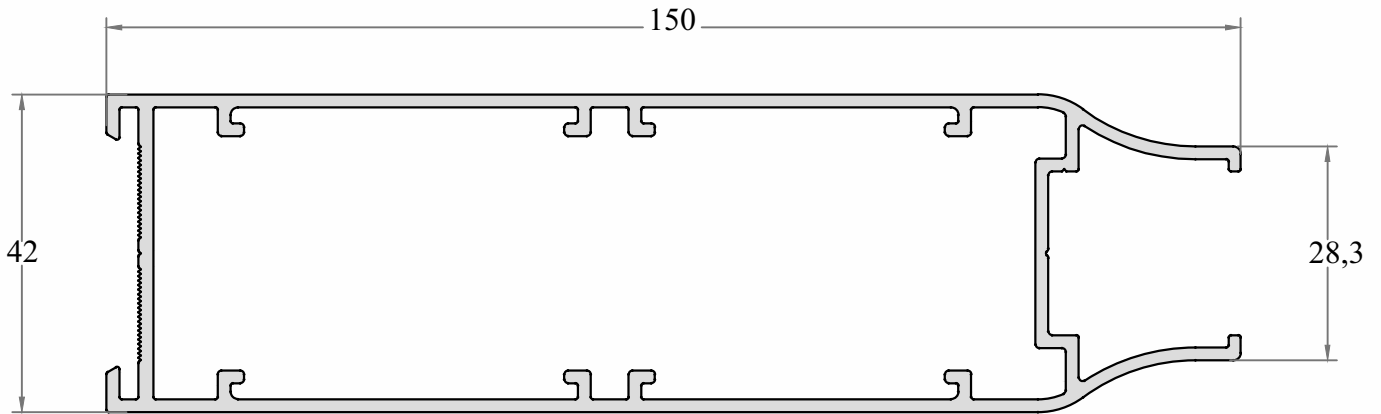

42-035	Folha Perimetral
Peso (Kg/m)	Perfis De Encaixe:
1,156	

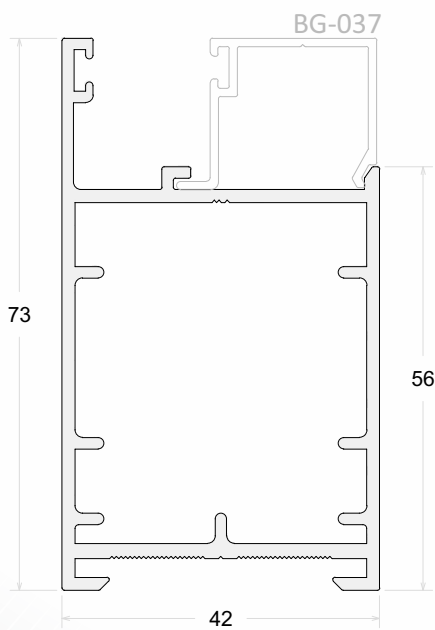

42-032	Folha Perimetral
Peso (Kg/m)	Perfis De Encaixe:
1,375	

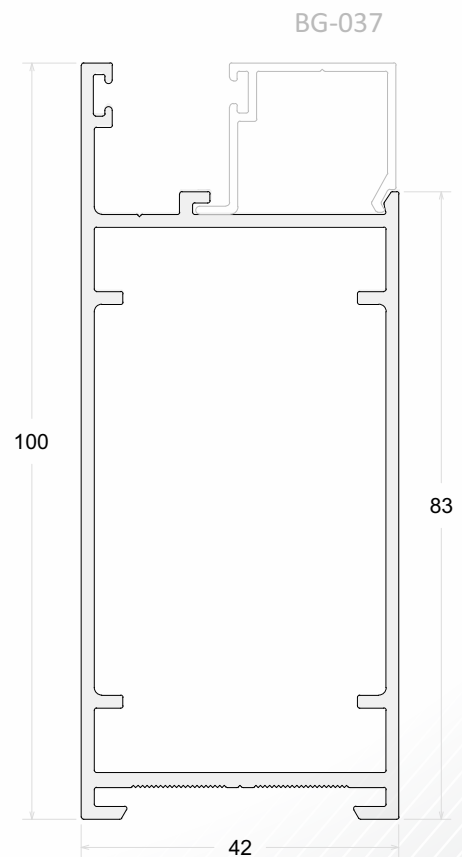

BG-037	Baguete Vertical e Horizontal
Peso (Kg/m)	Perfis De Encaixe:
0,208	

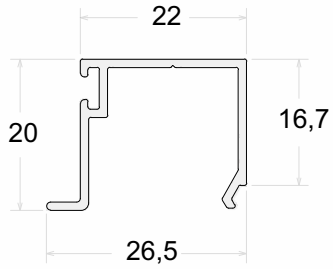

PLG-238	Redutor
Peso (Kg/m)	Perfis De Encaixe:
0,273	

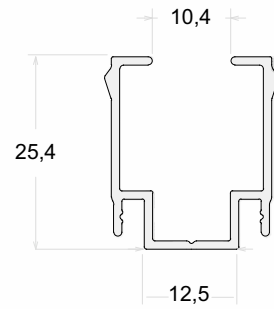

42-007	Travessa 100 mm
Peso (Kg/m)	Perfis De Encaixe:
1,331	

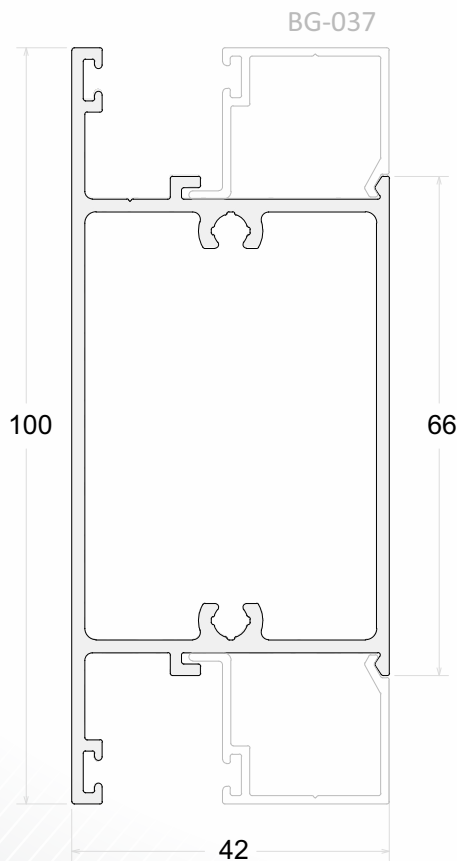

PLG-080	Travessa 62 mm
Peso (Kg/m)	Perfis De Encaixe:
0,984	

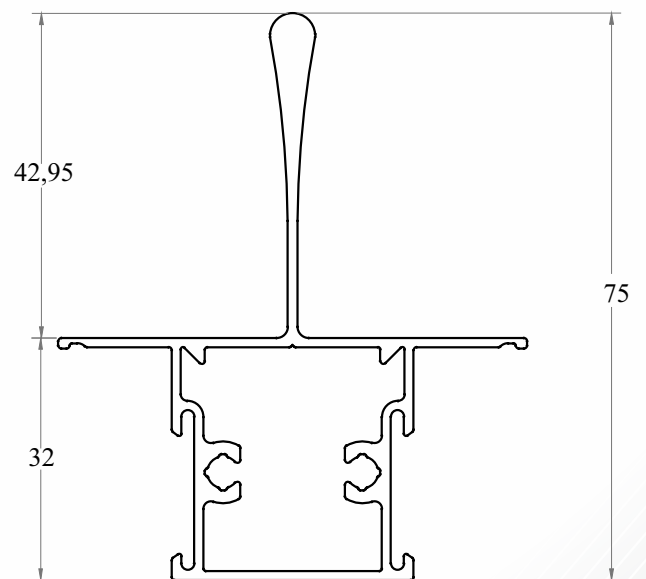



CG-078	Capa Do Corrimão
Peso (Kg/m)	Perfis De Encaixe:
0,359	

CG-780	Capa Do Corrimão
Peso (Kg/m)	Perfis De Encaixe:
0,408	

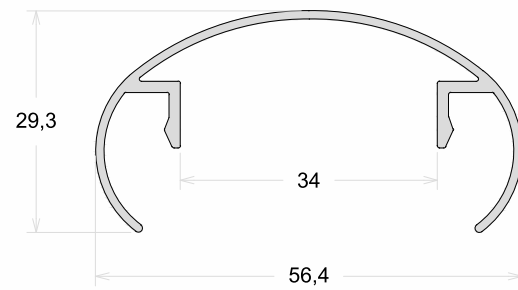
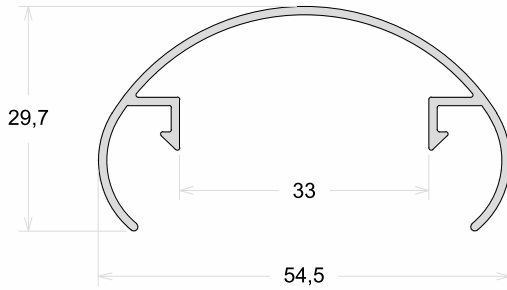

CG-079	Base Do Corrimão
Peso (Kg/m)	Perfis De Encaixe:
0,291	

CG-081	Click do Gradil
Peso (Kg/m)	Perfis De Encaixe: CG-079
0,173	

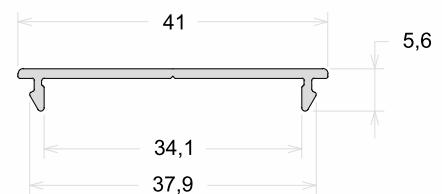
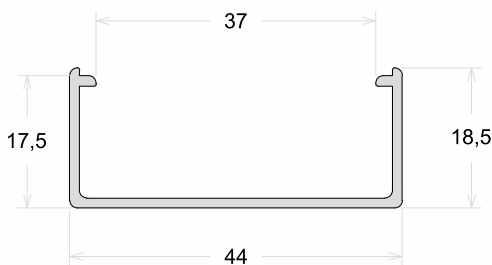

CG-056	Corrimão
Peso (Kg/m)	Perfis De Encaixe:
0,505	

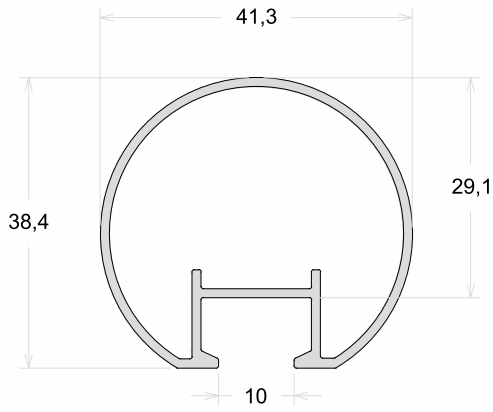

CG-012	Coluna
Peso (Kg/m)	Perfis De Encaixe:
0,444	

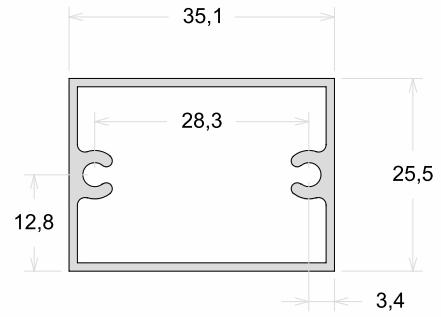

CG-022	Travessa Gradil
Peso (Kg/m)	Perfis De Encaixe:
0,224	

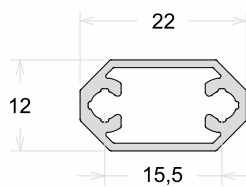

CG-021	Travessa Gradil
Peso (Kg/m)	Perfis De Encaixe:
0,326	

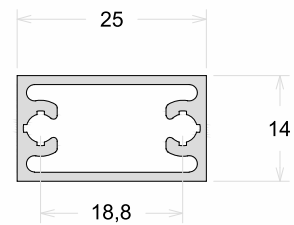



CG-013	Corrimão
Peso (Kg/m)	Perfis De Encaixe:
1,008	

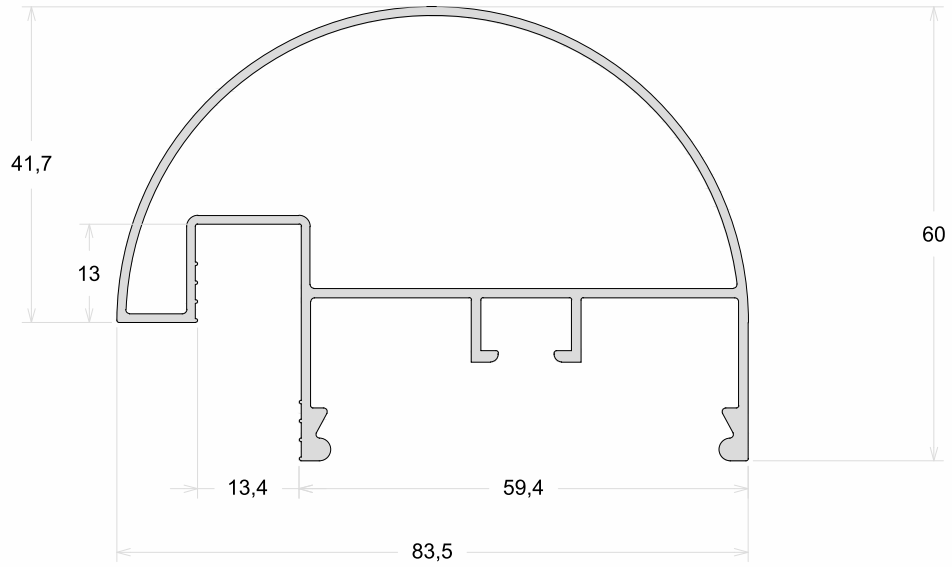

CG-063	Corrimão
Peso (Kg/m)	Perfis De Encaixe:
1,072	

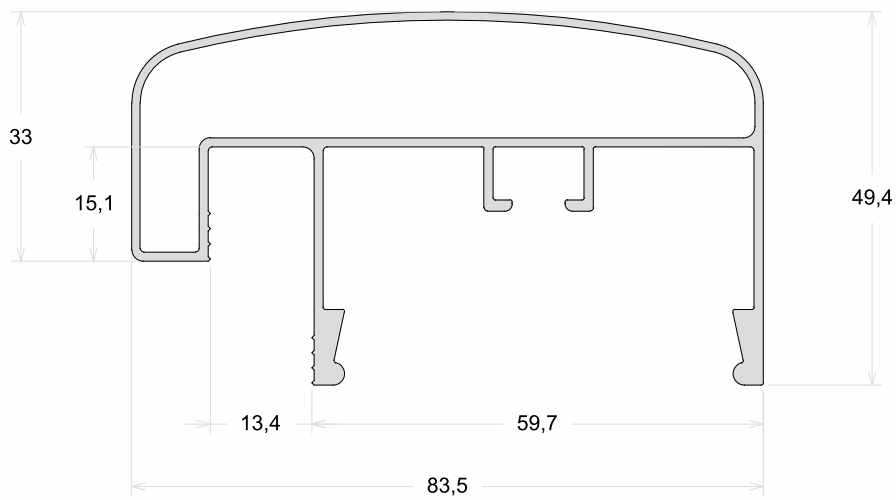



CG-083	Corrimão
Peso (Kg/m)	Perfis De Encaixe:
1,281	

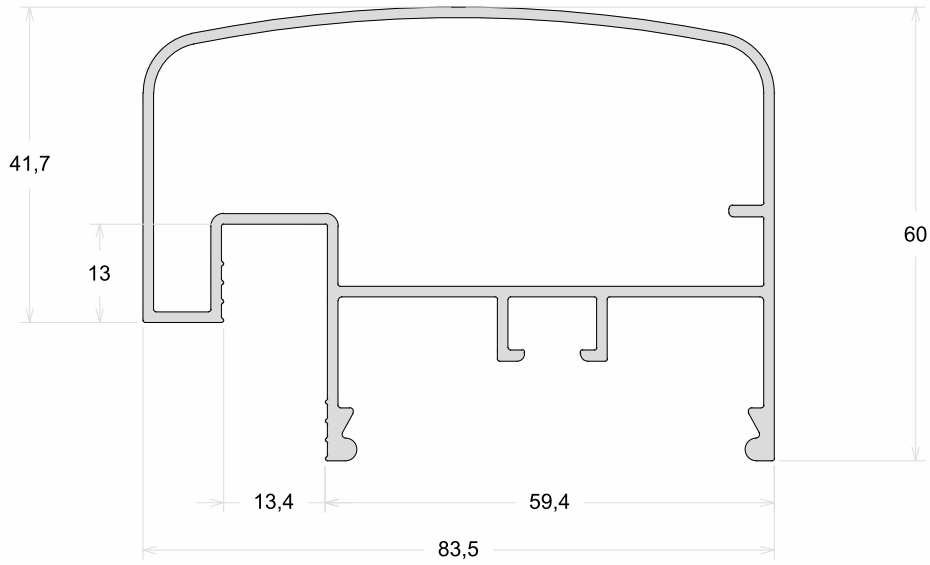

CG-830	Corrimão
Peso (Kg/m)	Perfis De Encaixe:
1,363	

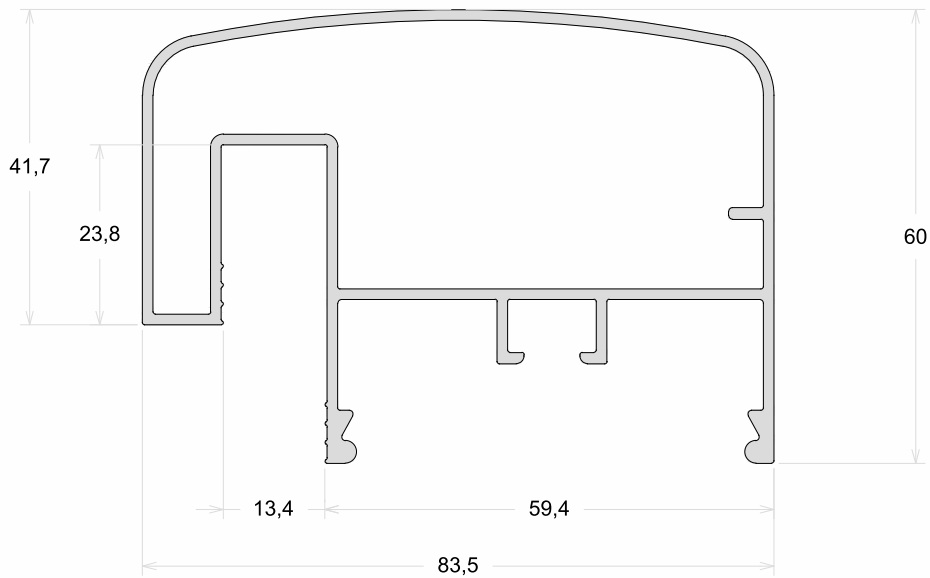



CG-085	Corrimão
Peso (Kg/m)	Perfis De Encaixe:
1,079	

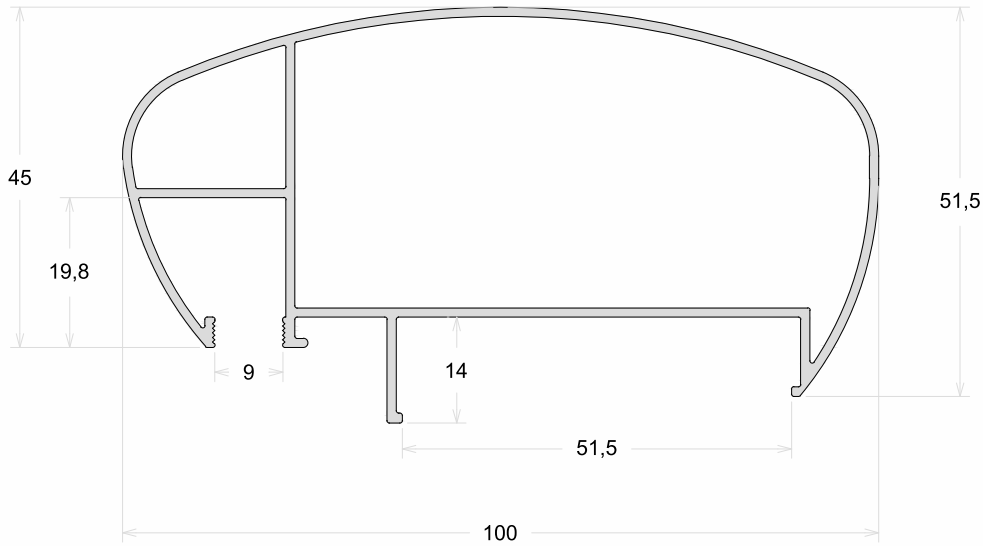

D-143	Corrimão
Peso (Kg/m)	Perfis De Encaixe:
1,216	

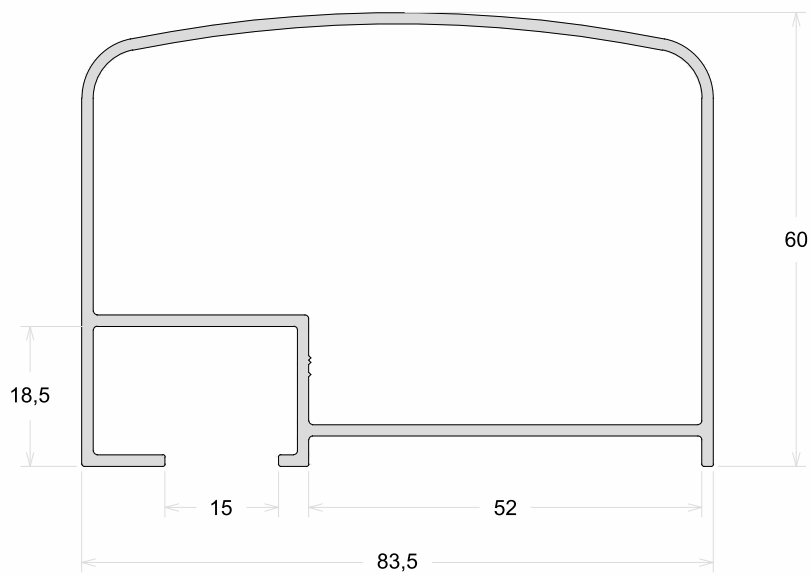

CG-077	Coluna
Peso (Kg/m)	Perfis De Encaixe:
0,720	

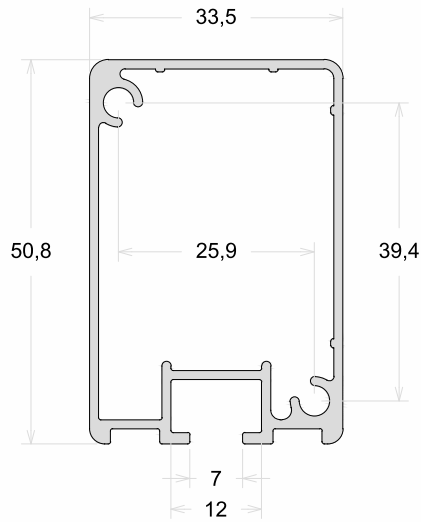

CG-084	Coluna
Peso (Kg/m)	Perfis De Encaixe:
0,578	

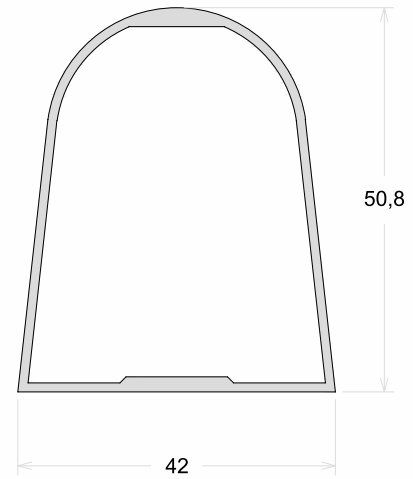

CG-076	Chumbador Para Coluna
Peso (Kg/m)	Perfis De Encaixe:
0,698	

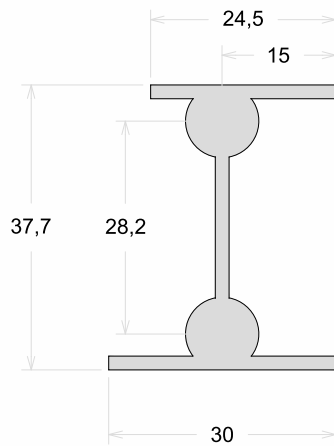

CG-074	Tampa Do Corrimão
Peso (Kg/m)	Perfis De Encaixe:
0,234	

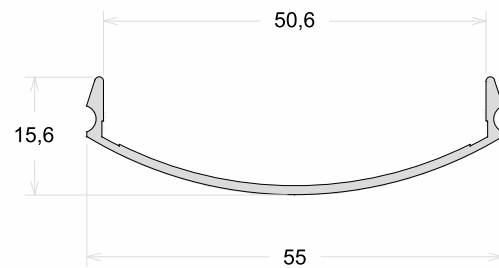



CG-015	Travessa Do Vidro
Peso (Kg/m)	Perfis De Encaixe:
0,164	

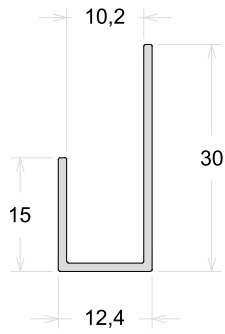

CG-750	Travessa Do Vidro
Peso (Kg/m)	Perfis De Encaixe:
0,452	

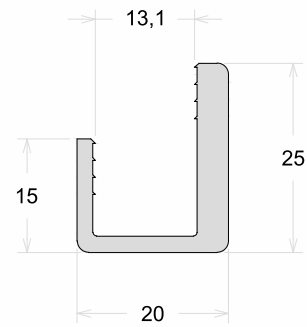

CG-075	Travessa Do Vidro
Peso (Kg/m)	Perfis De Encaixe:
0,460	

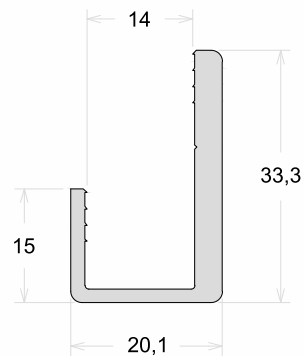



CG-885	Corrimão
Peso (Kg/m)	Perfis De Encaixe:
1,268	

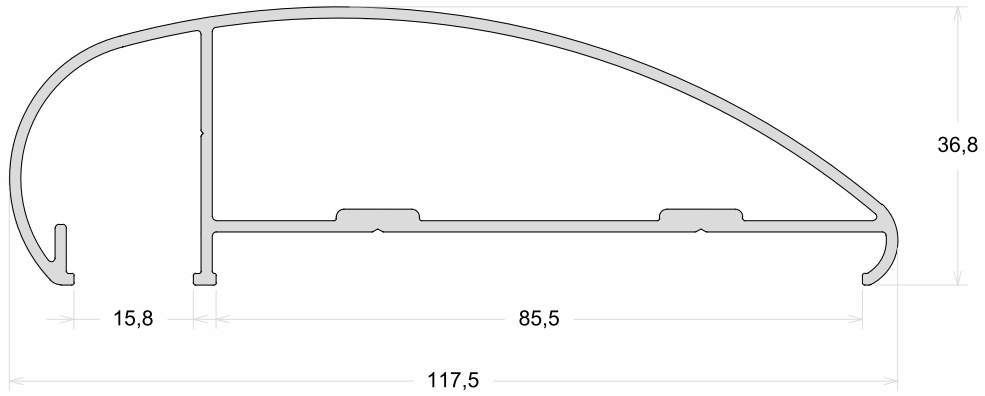

CG-300	Corrimão
Peso (Kg/m)	Perfis De Encaixe:
1,277	

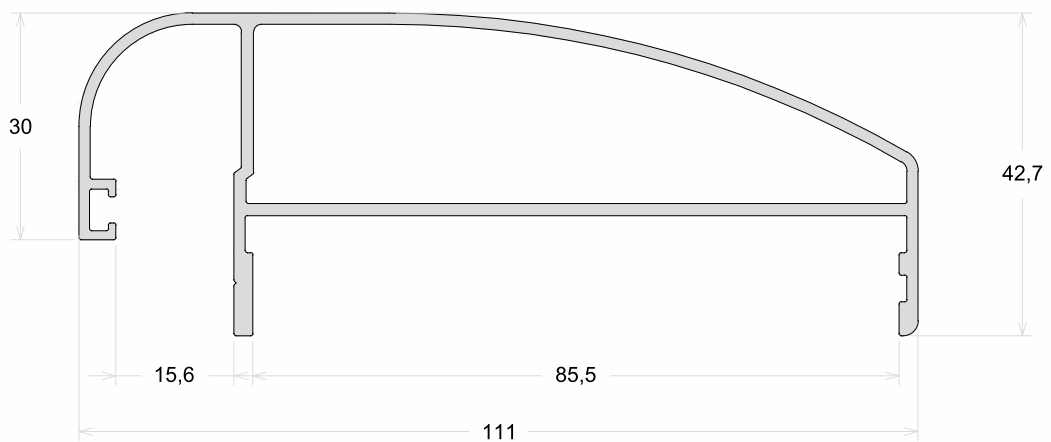



CG-833	Coluna
Peso (Kg/m)	Perfis De Encaixe:
0,993	

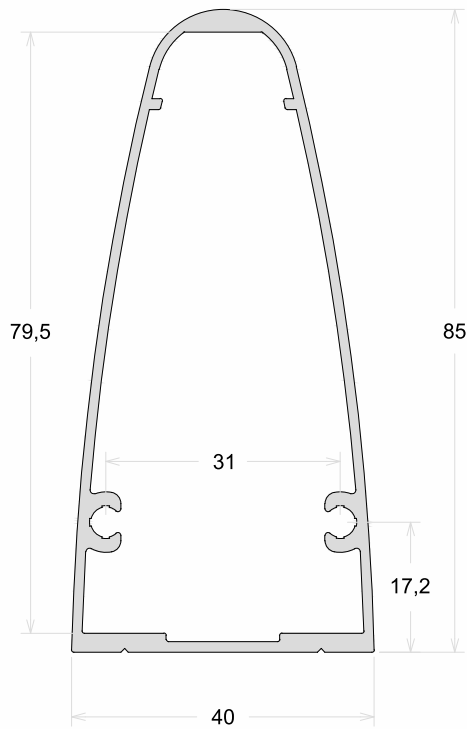

CG-834	Chumbador Para Coluna
Peso (Kg/m)	Perfis De Encaixe:
1,490	

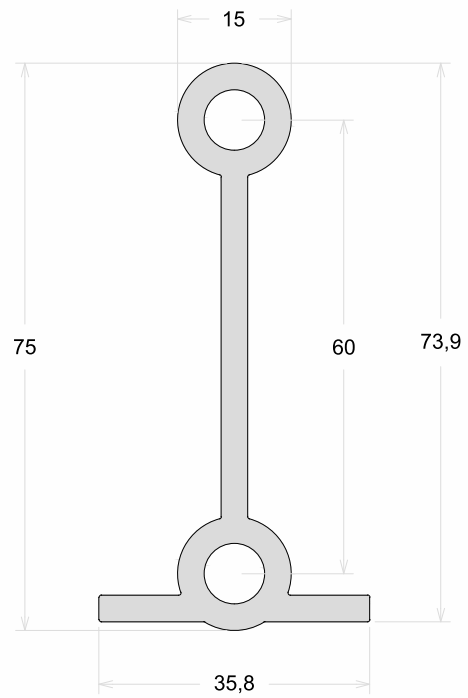

CG-837	Coluna
Peso (Kg/m)	Perfis De Encaixe:
1,428	

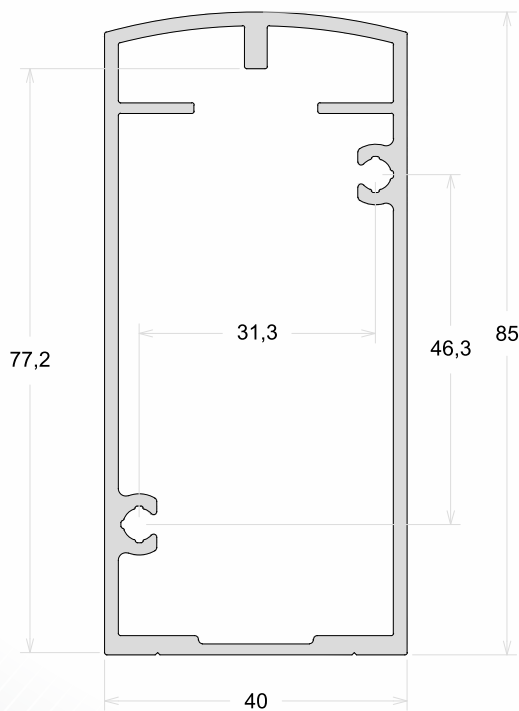

CX-651	Chumbador Para Coluna
Peso (Kg/m)	Perfis De Encaixe:
1,804	

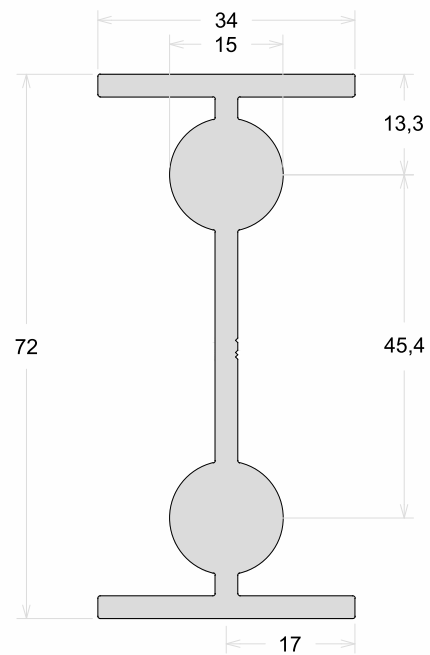



CG-080	Chumbador Para Coluna
Peso (Kg/m)	Perfis De Encaixe:
1,617	

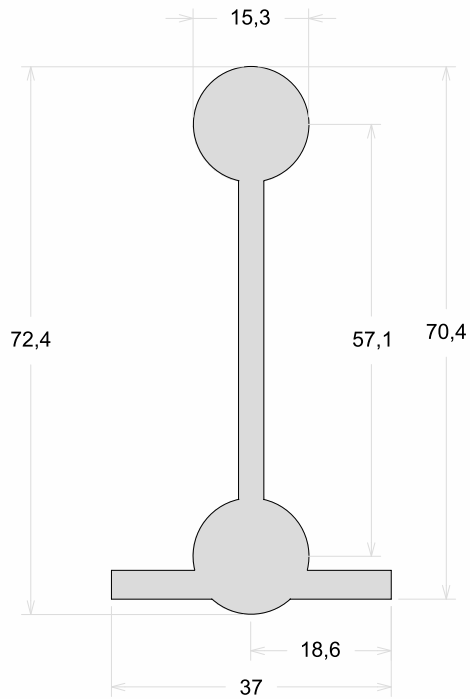

CG-887	Travessa Do Vidro
Peso (Kg/m)	Perfis De Encaixe:
0,460	

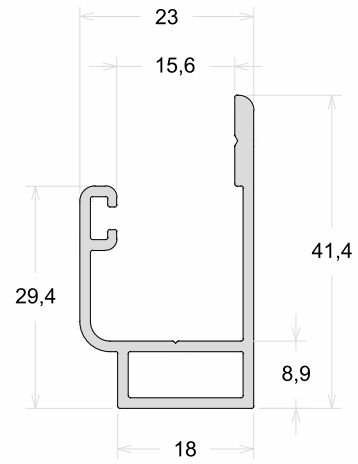

PSL-012	Marco Superior
Peso (Kg/m)	Perfis De Encaixe:
0,531	

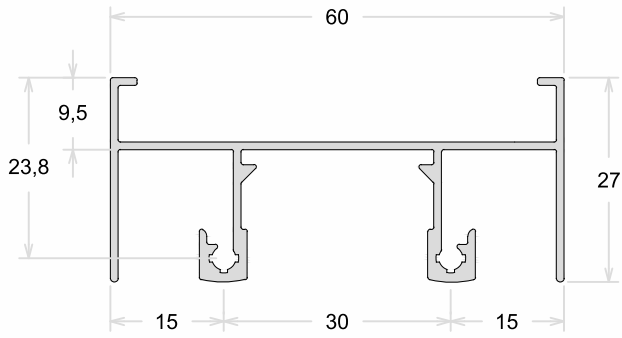

PSL-013	Marco Lateral
Peso (Kg/m)	Perfis De Encaixe:
0,332	

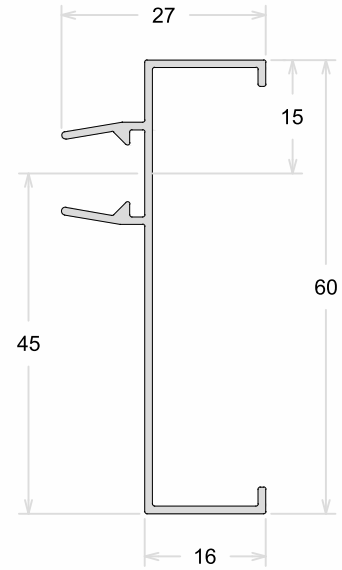

PSL-014	Marco Inferior
Peso (Kg/m)	Perfis De Encaixe:
0,566	

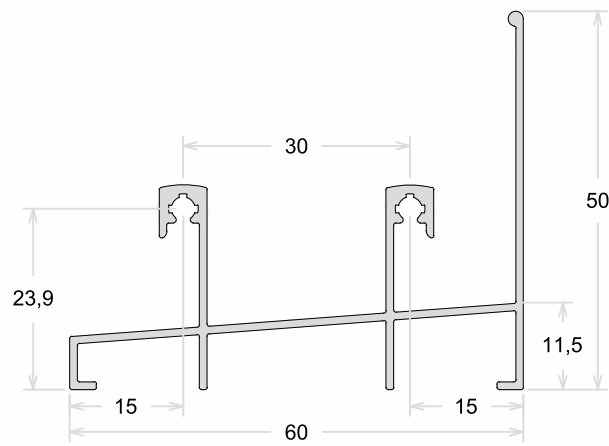

PSL-010	Marco Superior
Peso (Kg/m)	Perfis De Encaixe:
0,712	

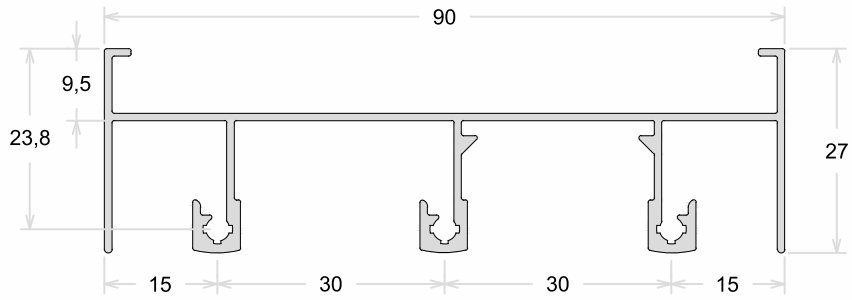

PSL-011	Marco Inferior
Peso (Kg/m)	Perfis De Encaixe:
0,739	

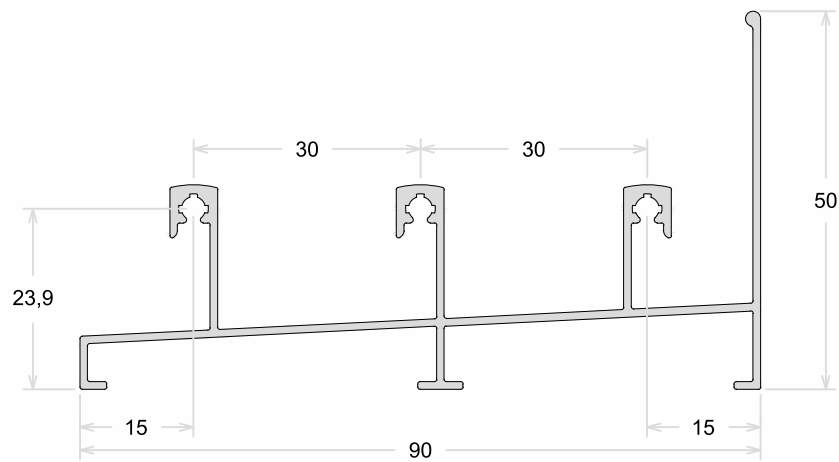

PSL-008	Marco Lateral
Peso (Kg/m)	Perfis De Encaixe:
0,488	

PSL-009	Marco Lateral
Peso (Kg/m)	Perfis De Encaixe:
0,413	

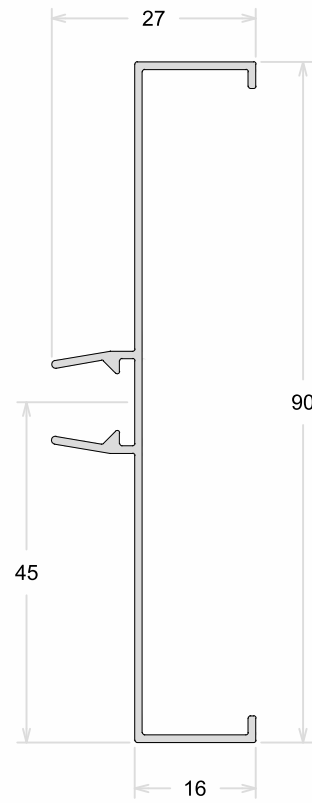
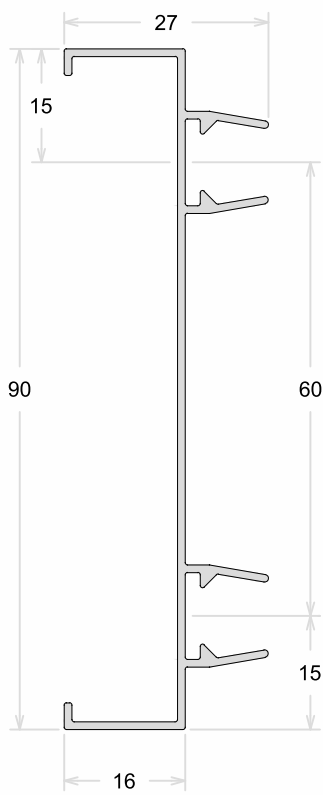

PSL-007	Folha Horizontal
Peso (Kg/m)	Perfis De Encaixe:
0,325	

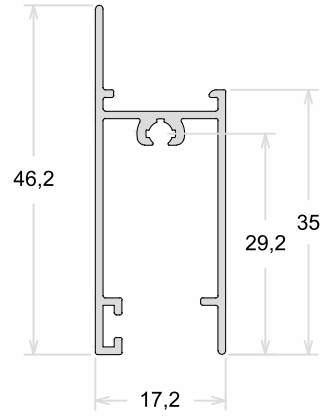

PSL-001	Folha Lateral
Peso (Kg/m)	Perfis De Encaixe:
0,366	

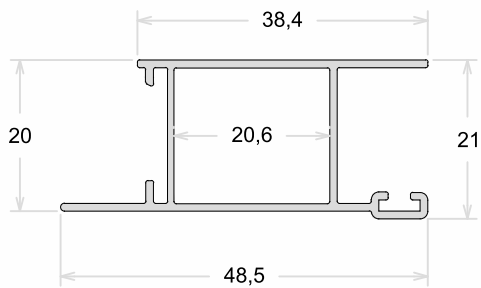

PSL-017	Folha Central
Peso (Kg/m)	Perfis De Encaixe:
0,378	

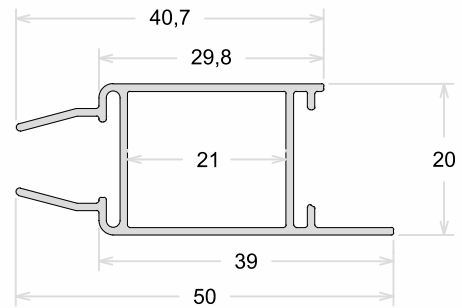

PSL-005	Folha Mão De Amigo Interno
Peso (Kg/m)	Perfis De Encaixe:
0,345	

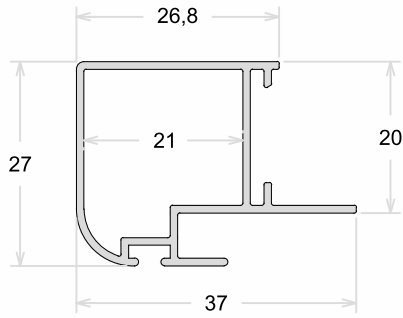

PSL-016	Folha Mão De Amigo Externo
Peso (Kg/m)	Perfis De Encaixe:
0,345	

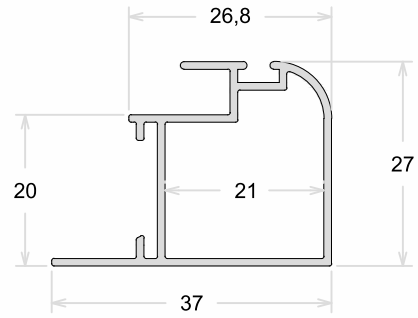

PSL-006	Folha Horizontal - Veneziana
Peso (Kg/m)	Perfis De Encaixe:
0,340	

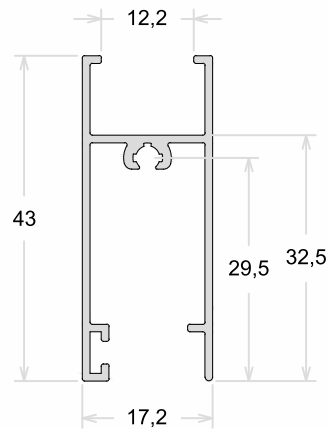

PSL-002	Folha Lateral - Veneziana
Peso (Kg/m)	Perfis De Encaixe:
0,387	

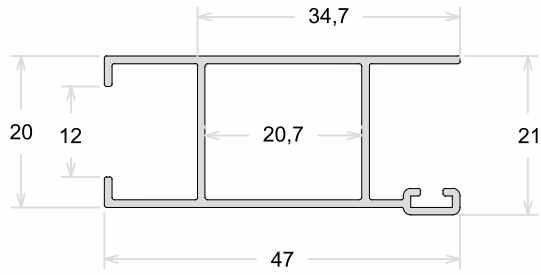

PSL-015	Folha Central - Veneziana
Peso (Kg/m)	Perfis De Encaixe:
0,404	

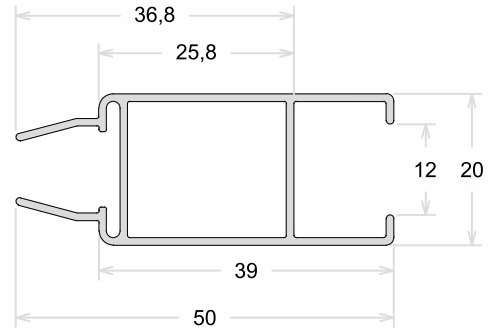

PSL-003	Folha Mão De Amigo Central Veneziana
Peso (Kg/m)	Perfis De Encaixe:
0,428	

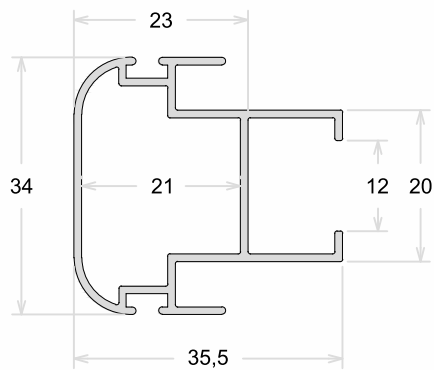

PSL-004	Folha Mão De Amigo Veneziana
Peso (Kg/m)	Perfis De Encaixe:
0,367	

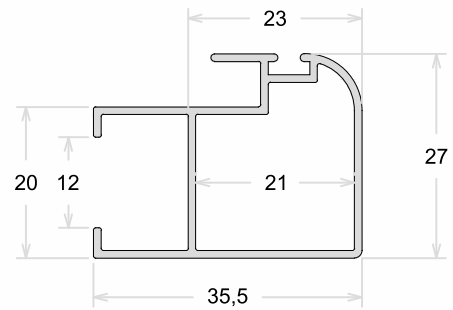

BG-011	Baguete Horizontal
Peso (Kg/m)	Perfis De Encaixe:
0,096	

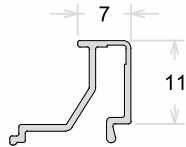

BG-012	Baguete Vertical
Peso (Kg/m)	Perfis De Encaixe:
0,095	

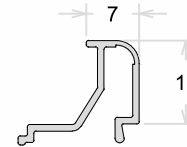

VZ-080	Veneziana
Peso (Kg/m)	Perfis De Encaixe:
0,222	

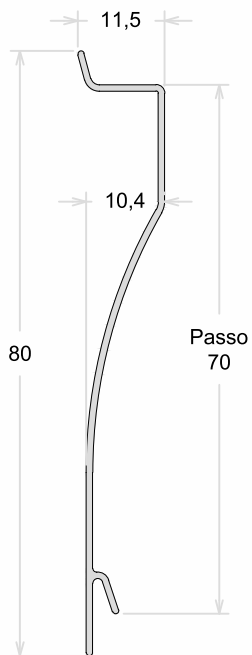

VZ-080 VT	Veneziana Ventilada
Peso (Kg/m)	Perfis De Encaixe:
0,222	

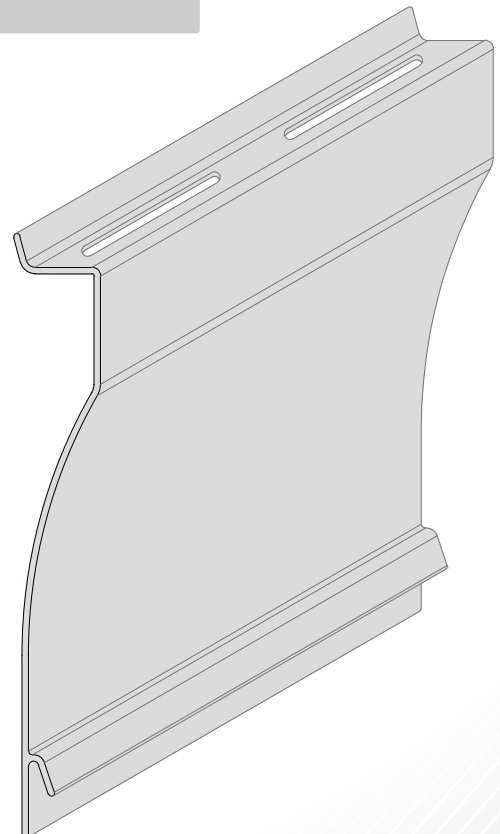

PSU-001	PSU-001S	Marco Superior
Peso (Kg/m)	Peso (Kg/m)	Perfis De Encaixe:
0,674	0,754	PSU-003 / PSU-007 / PSU-303

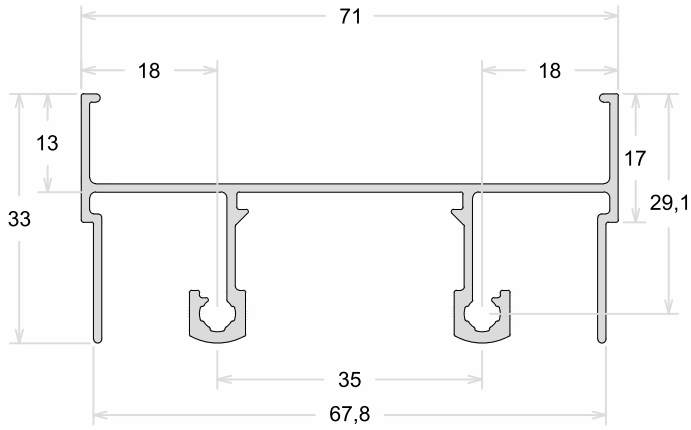

PSU-003	PSU-003S	Marco Lateral
Peso (Kg/m)	Peso (Kg/m)	Perfis De Encaixe:
0,415	0,493	PSU-001 / PSU-002/PSU-228 / E-578

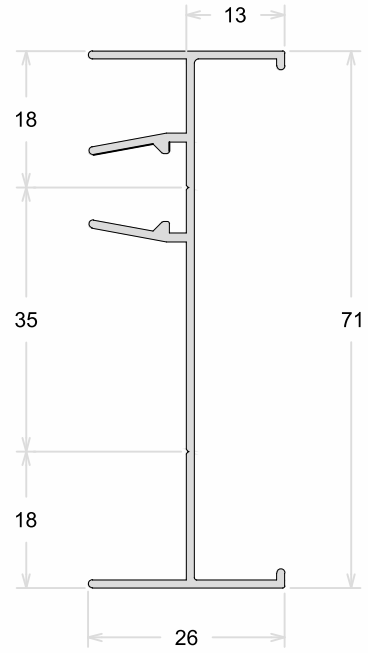

PSU-002	Marco Inferior
Peso (Kg/m)	Perfis De Encaixe:
0,611	PSU-003 / PSU-007 / PSU-303

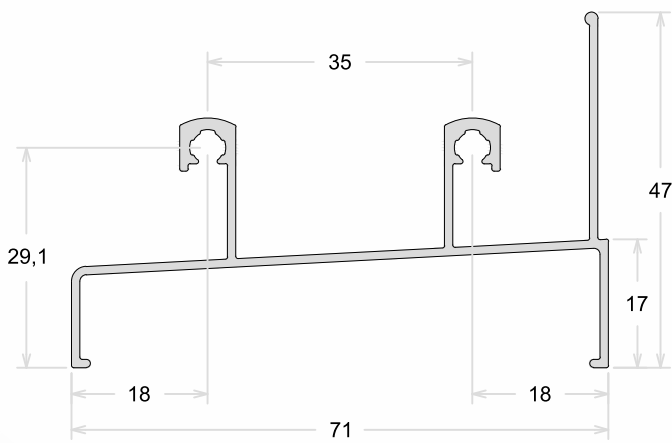

PSU-303	Marco Lateral
Peso (Kg/m)	Perfis De Encaixe:
0,453	PSU-001 / PSU-002/PSU-228 / E-578

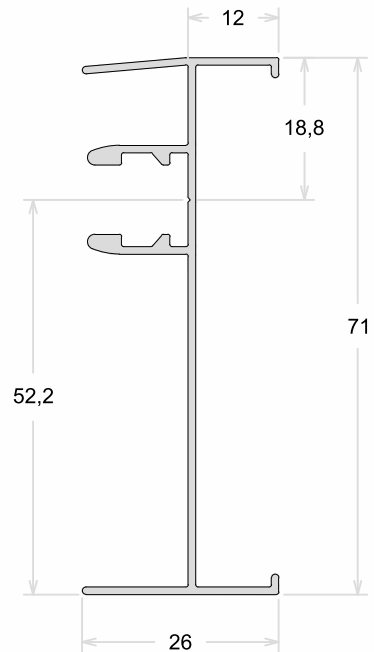

PSU-007	Marco Lateral Liso
Peso (Kg/m)	Perfis De Encaixe: PSU-001 / PSU-002
0,355	PSU-004 / PSU-228 / E-578 / PSU-005 P-634 / PSU-006 / PSU-009

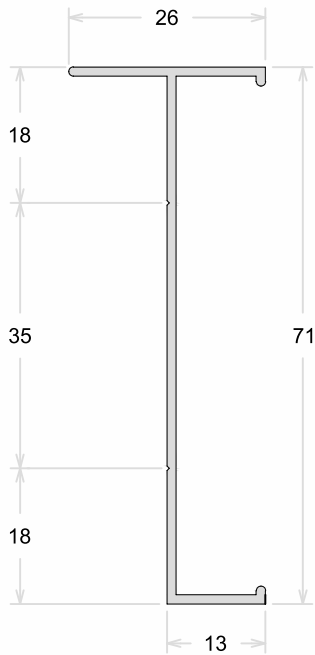

PSU-004	PSU-004S	Marco Bandeira / Peitoril
Peso (Kg/m)	Peso (Kg/m)	Perfis De Encaixe: PSU-007
0,454	0,476	

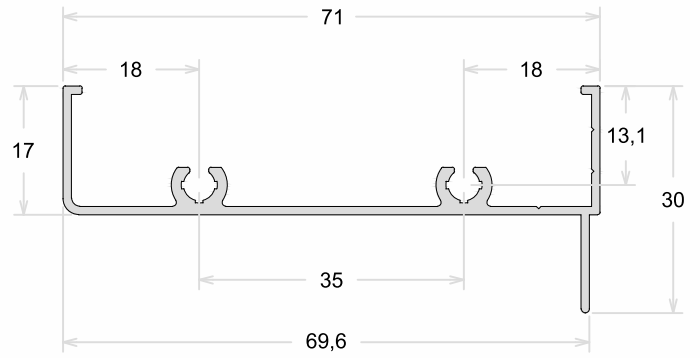

PSU-228	Marco Inferior
Peso (Kg/m)	Perfis De Encaixe: PSU-003 / PSU-303 / PSU-007
0,650	

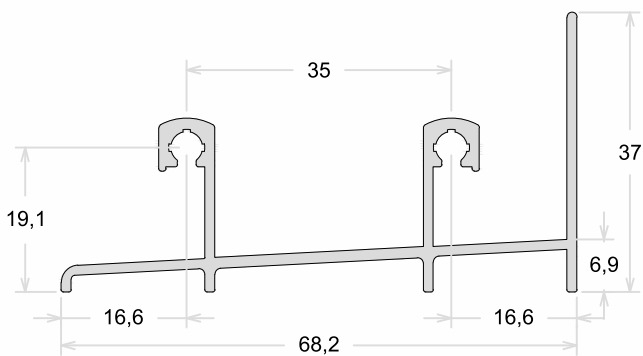

E-578	Marco Inferior
Peso (Kg/m)	Perfis De Encaixe: PSU-003 / PSU-303 / PSU-007
0,704	

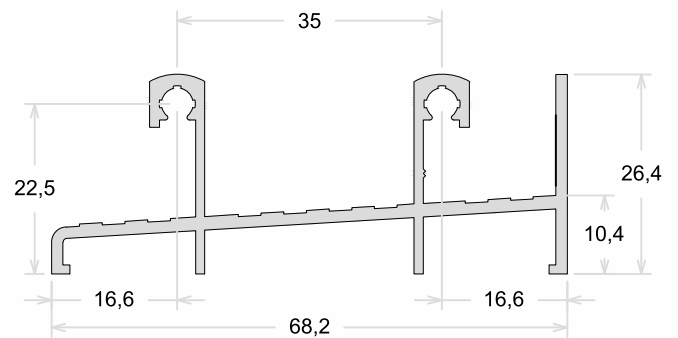

PSU-130	Marco Inferior
Peso (Kg/m)	Perfis De Encaixe: PSU-2586
0,685	

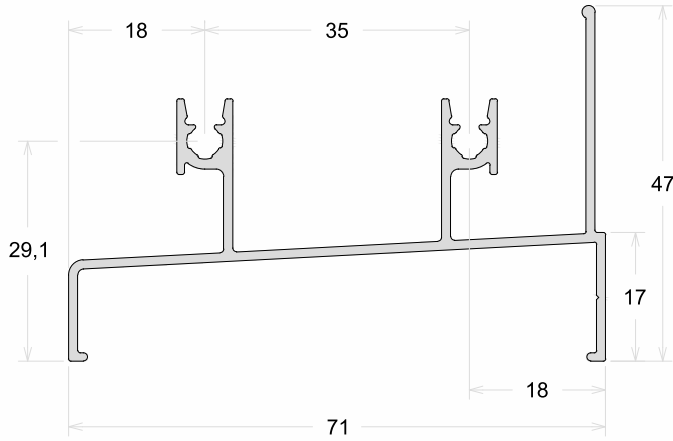

PSU-131	Marco Inferior
Peso (Kg/m)	Perfis De Encaixe: PSU-2586
0,673	

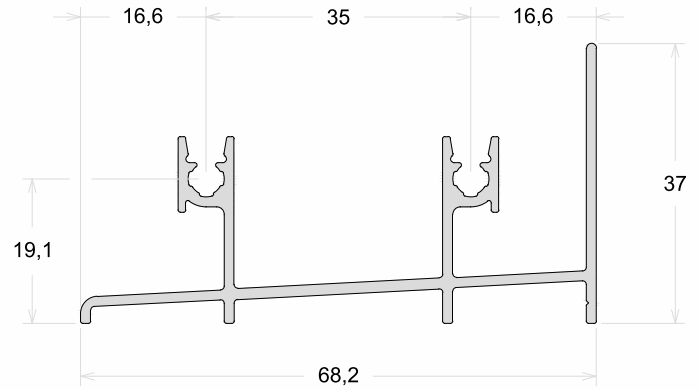

PSU-132	Travessa Peitoril
Peso (Kg/m)	Perfis De Encaixe: PSU-2586
0,945	

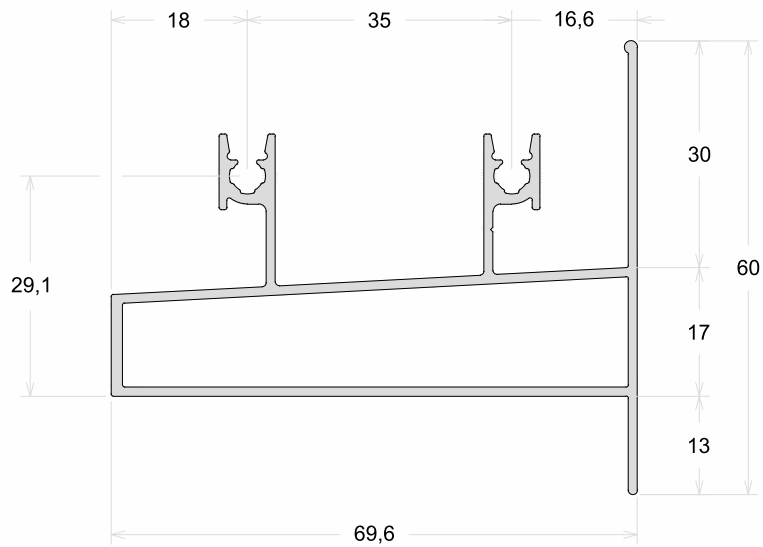

PSU-005	Travessa Intermediária Bandeira
Peso (Kg/m)	Perfis De Encaixe: PSU-007
0,846	

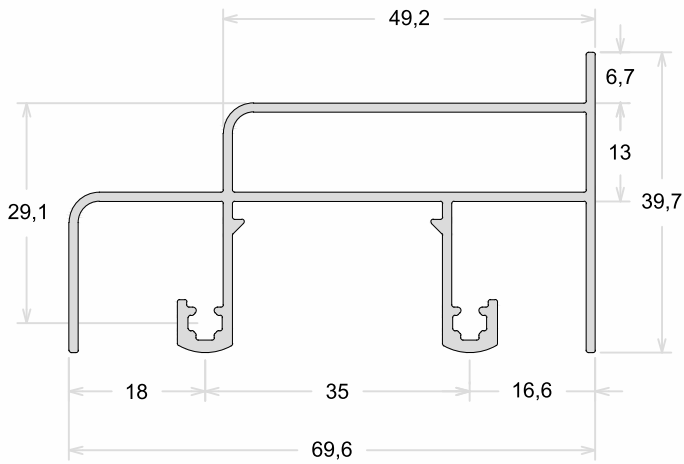

P-634	Travessa Intermediária Bandeira
Peso (Kg/m)	Perfis De Encaixe: PSU-007
0,950	

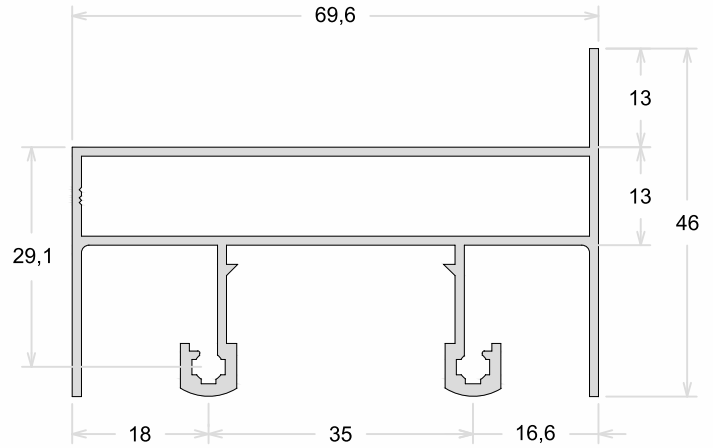

PSU-006	Travessa Intermediária Peitoril
Peso (Kg/m)	Perfis De Encaixe: PSU-007
0,841	

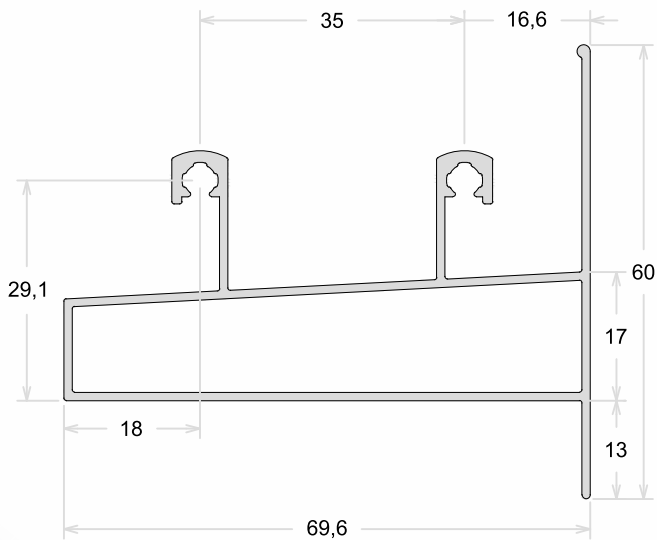

PSU-009	P-636	Coluna
Peso (Kg/m)	Peso (Kg/m)	Perfis De Encaixe: PSU-007
0,854	0,908	

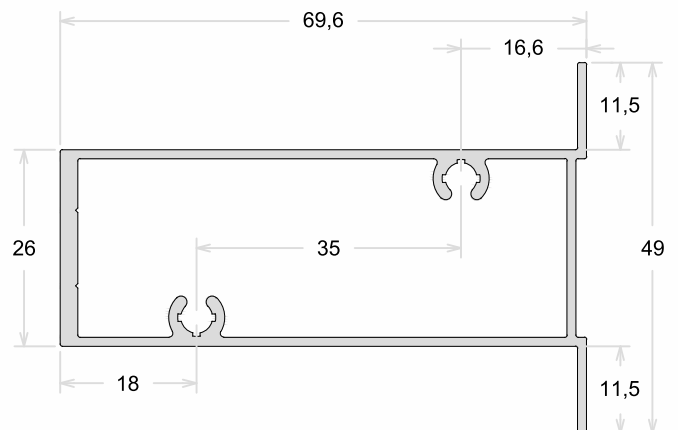

PSU-010	PSU-010S	Marco Superior
Peso (Kg/m)	Peso (Kg/m)	Perfis De Encaixe:
0,955	1,011	PSU-012 / PSU-013 / PSU-014

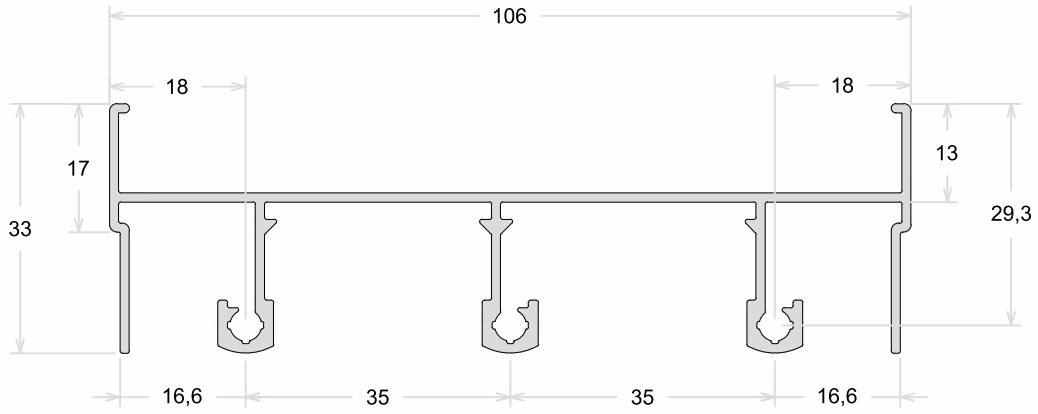

PSU-011	Marco Inferior
Peso (Kg/m)	Perfis De Encaixe:
0,900	PSU-012 / PSU-013 / PSU-014

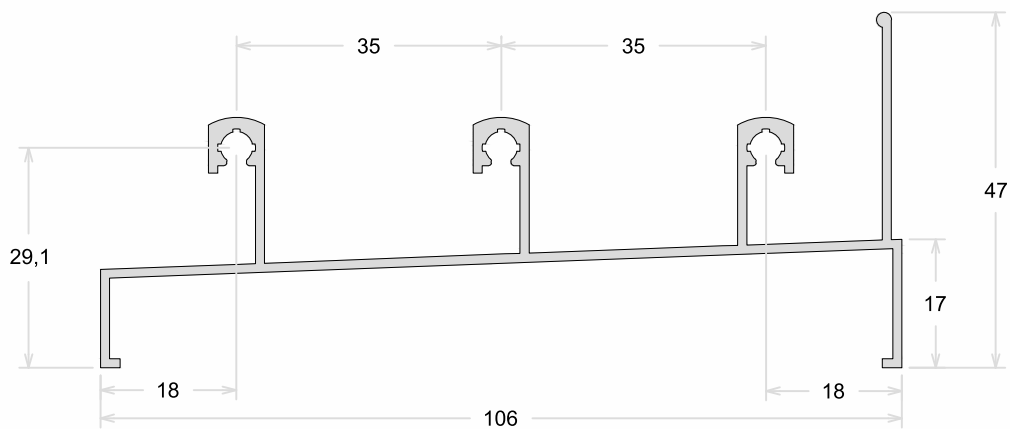

PSU-230	Marco Inferior
Peso (Kg/m)	Perfis De Encaixe: PSU-012 / PSU-013 / PSU-014
0,921	

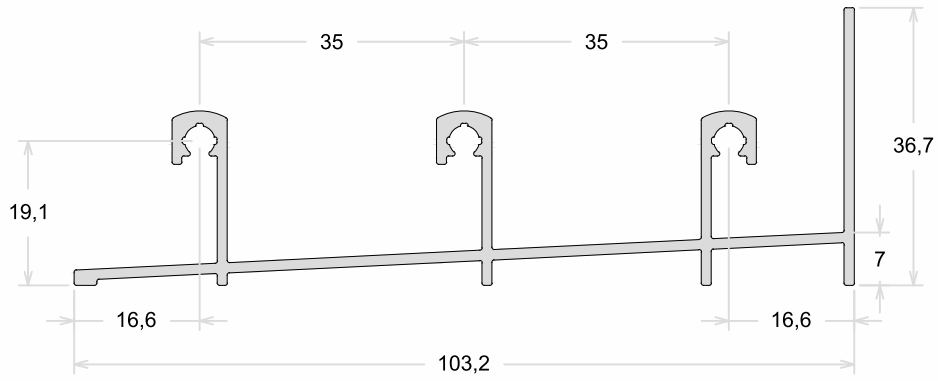

E-580	Marco Inferior
Peso (Kg/m)	Perfis De Encaixe: PSU-012 / PSU-013 / PSU-014
0,993	

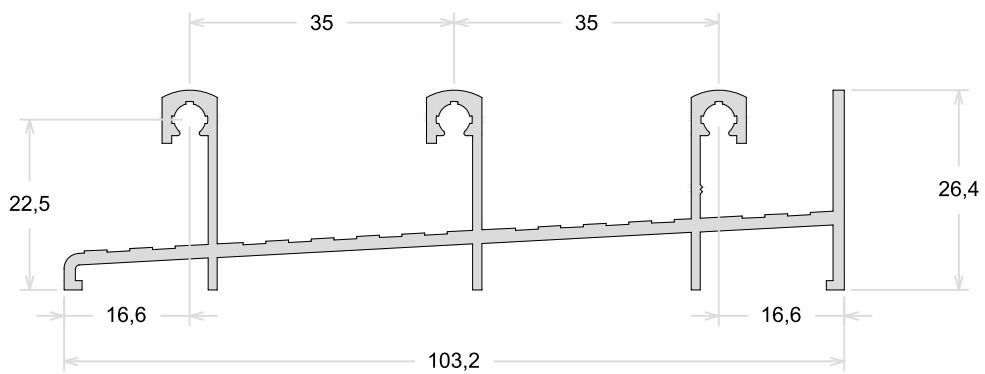

PSU-013	PSU-013S	Marco Lateral
Peso (Kg/m)	Peso (Kg/m)	Perfis De Encaixe:
0,700	0,769	PSU-010 / PSU-011 / PSU-230 / E-580

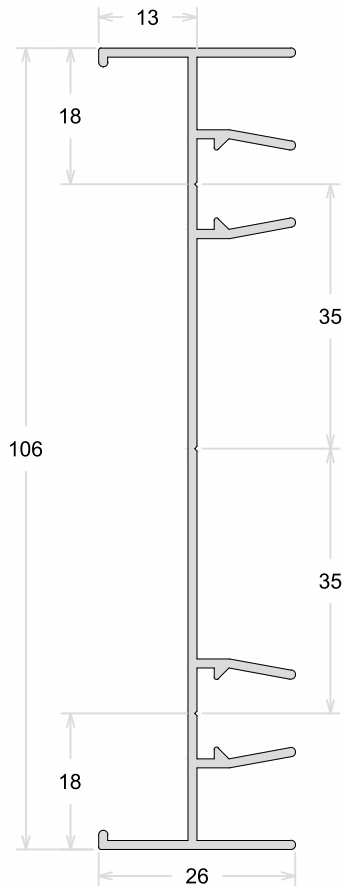

PSU-014	PSU-014S	Marco Lateral
Peso (Kg/m)	Peso (Kg/m)	Perfis De Encaixe:
0,600	0,674	PSU-010 / PSU-011 / PSU-230 / E-580

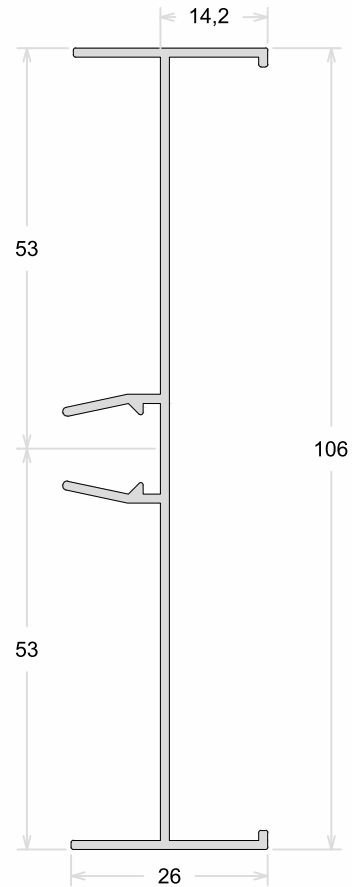

PSU-012	PSU-012S	Marco Lateral Liso
Peso (Kg/m)	Peso (Kg/m)	Perfis De Encaixe:
0,509	0,540	PSU-010 / PSU-011 / PSU-230 / E-580 PSU-019 / PSU-018

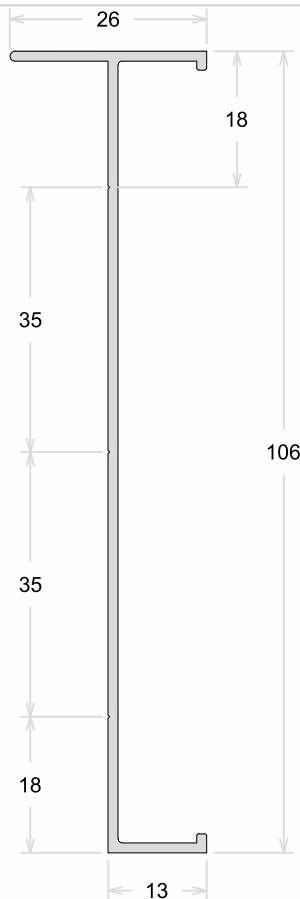

PSU-018	Marco Bandeira / Peitoril
Peso (Kg/m)	Perfis De Encaixe: PSU-012
0,631	

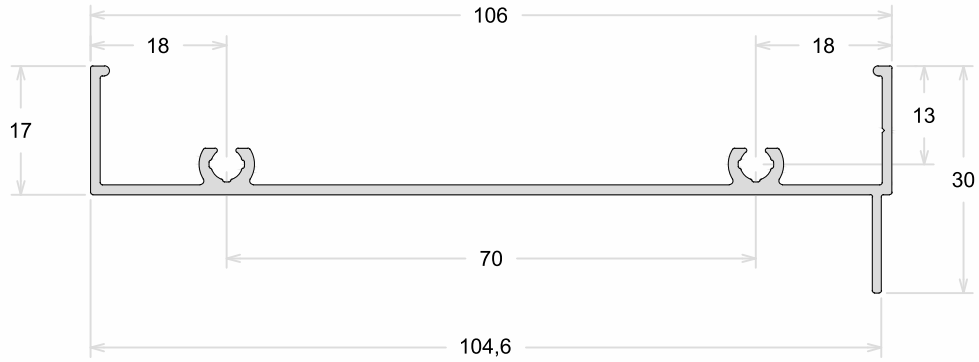

PSU-019	Travessa Intermediária Bandeira
Peso (Kg/m)	Perfis De Encaixe: PSU-012
1,762	

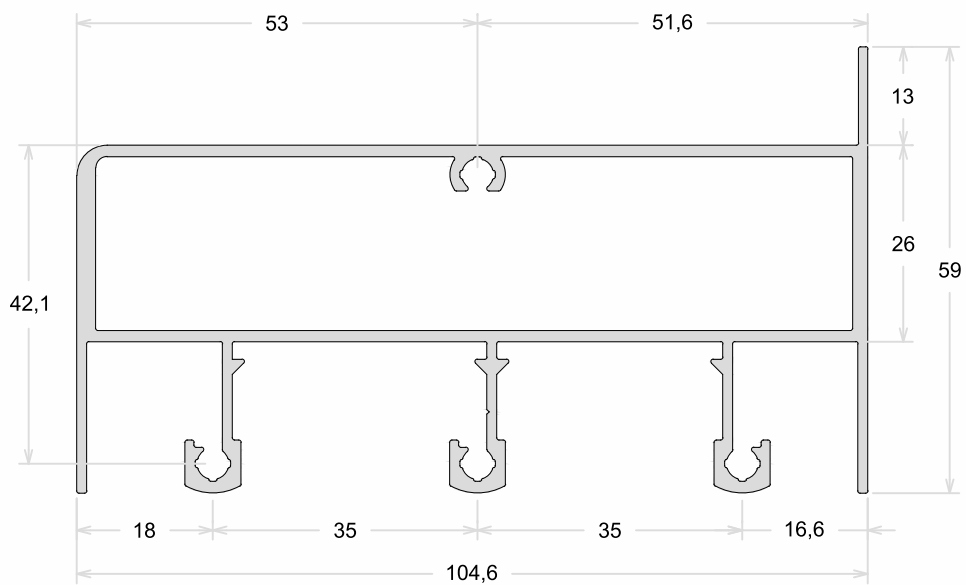

PSU-133	Marco Inferior
Peso (Kg/m)	Perfis De Encaixe: PSU-2586
0,931	

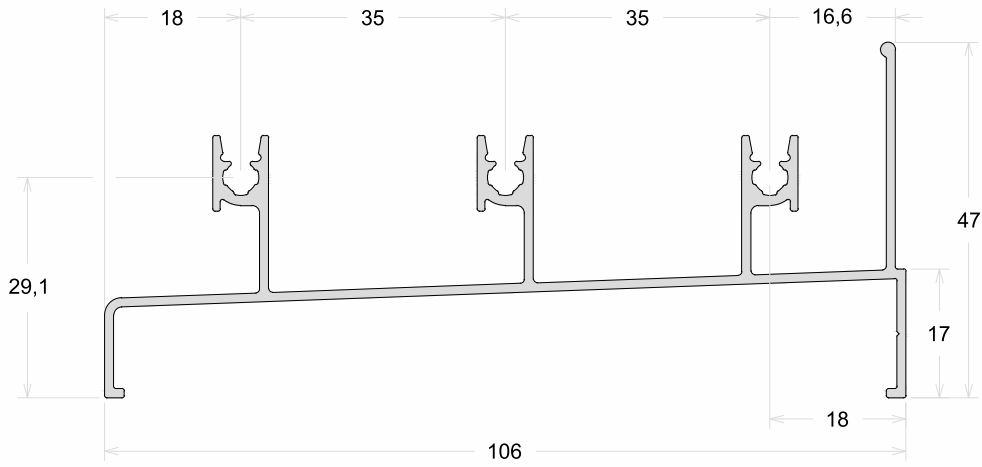

PSU-134	Marco Inferior
Peso (Kg/m)	Perfis De Encaixe: PSU-2586
0,959	

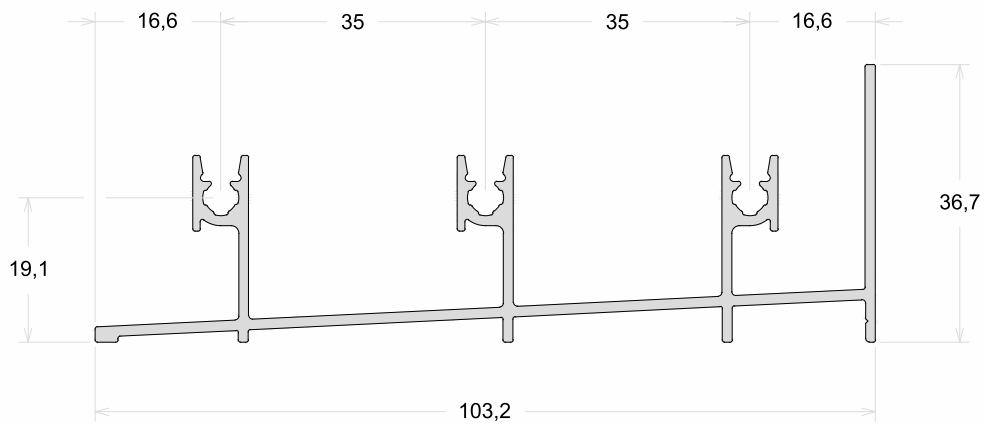

PSU-135	Travessa Peitoril
Peso (Kg/m)	Perfis De Encaixe: PSU-2586
1,570	

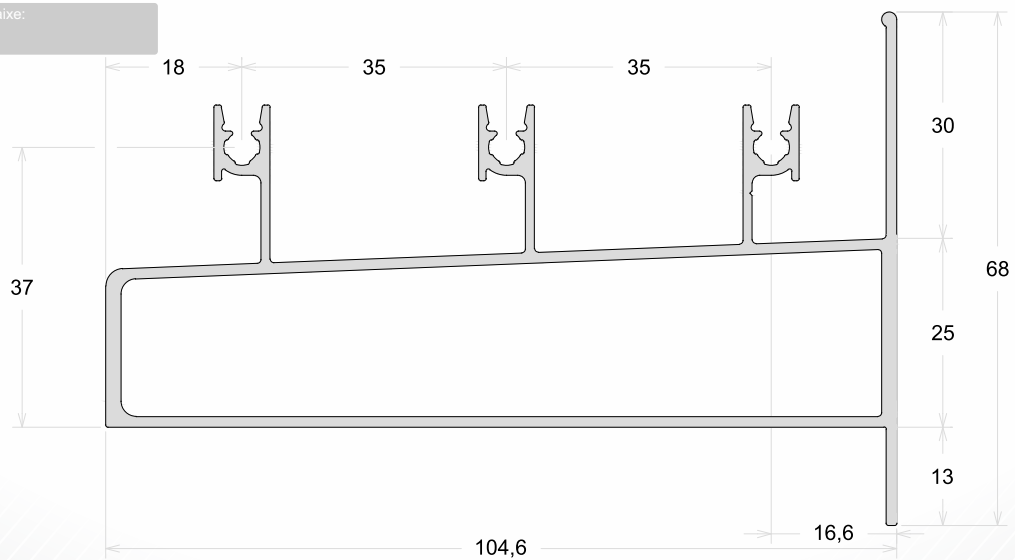

PSU-121	Marco Superior
Peso (Kg/m)	Perfis De Encaixe: PSU-123
1,420	

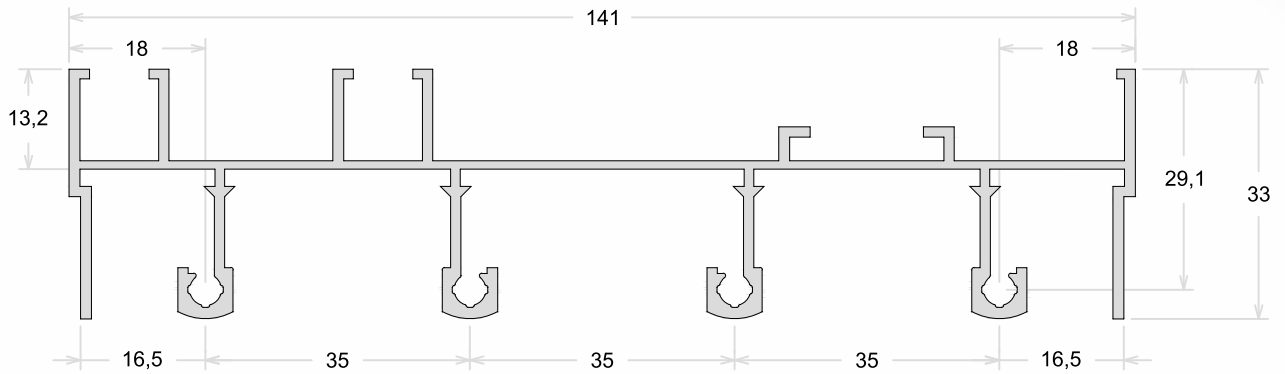

PSU-122	Marco Inferior
Peso (Kg/m)	Perfis De Encaixe: PSU-123
1,435	

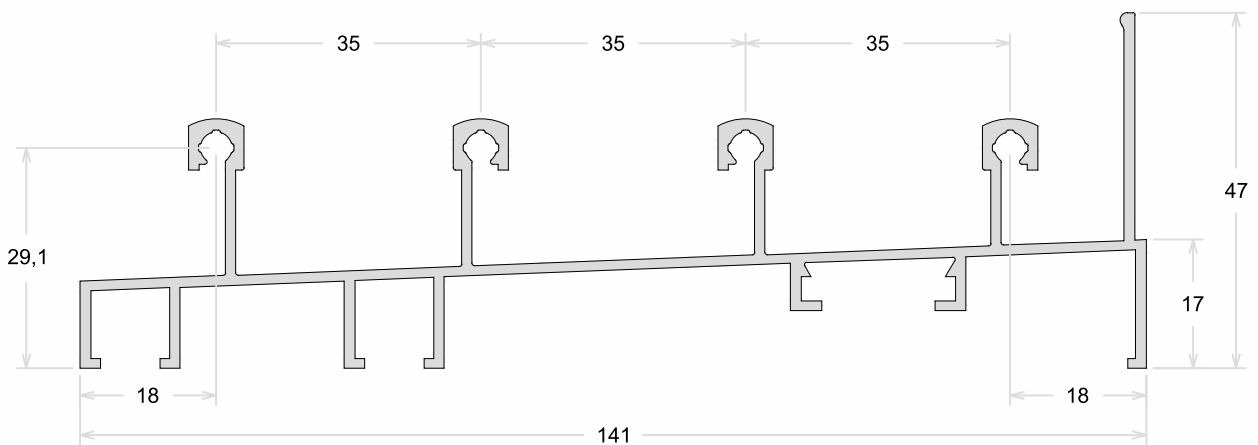

PSU-123	Marco Lateral Liso
Peso (Kg/m)	Perfis De Encaixe: PSU-121 / PSU-122
0,802	

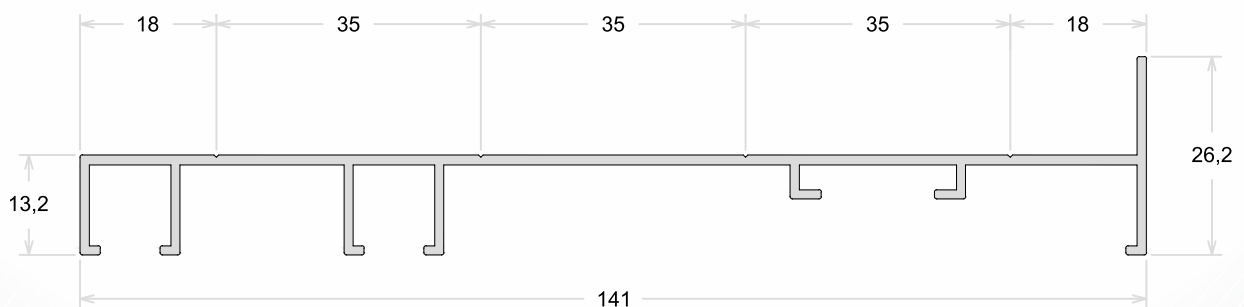

PSU-136	Marco Inferior
Peso (Kg/m)	Perfis De Encaixe: PSU-2586
1,347	

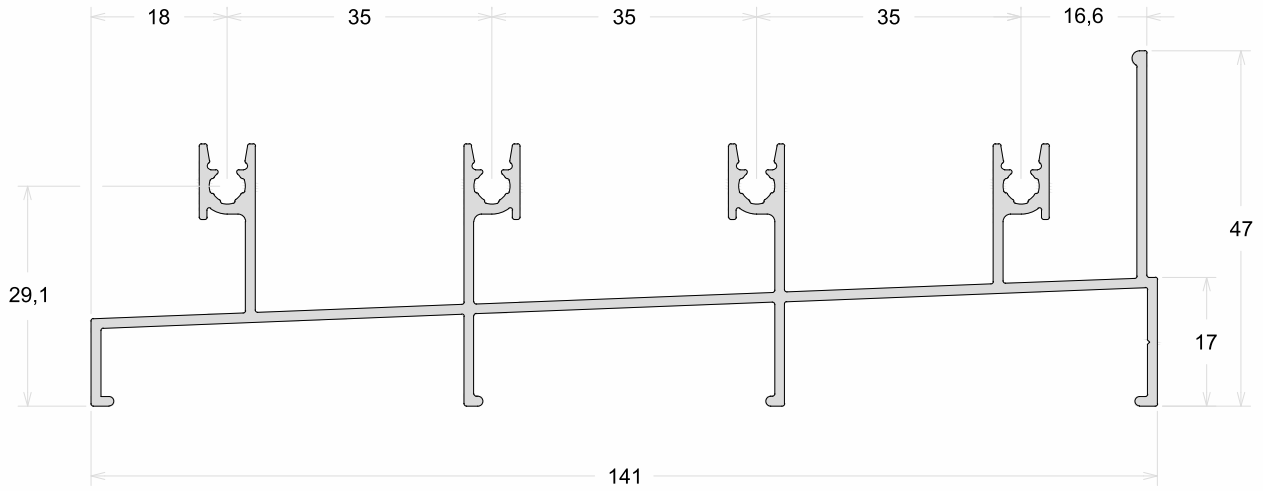

PSU-137	Marco Inferior
Peso (Kg/m)	Perfis De Encaixe: PSU-2586
1,176	

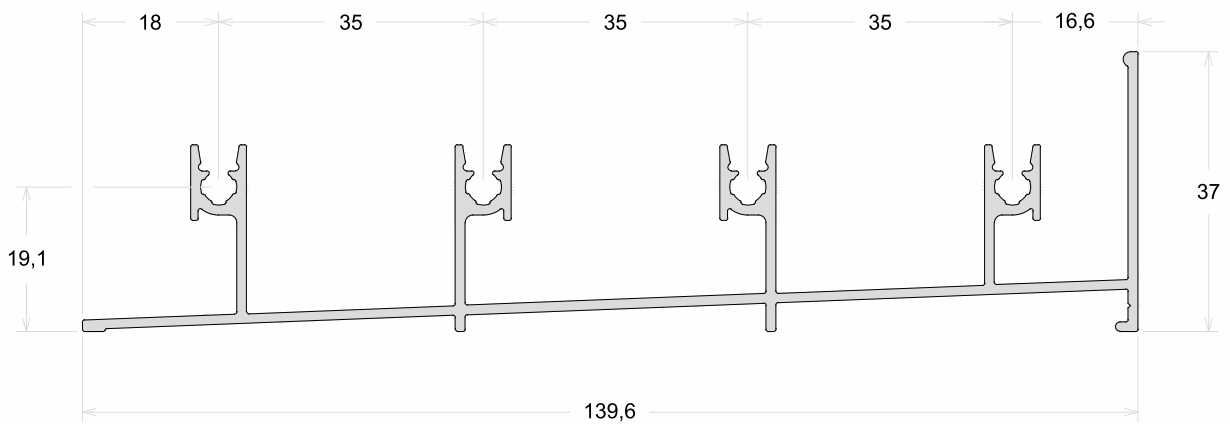

PSU-008

Complemento Marco Lateral

Peso
(Kg/m)
0,197

Perfis De Encaixe:

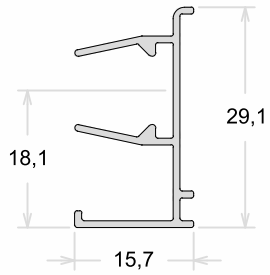

PSU-234

Complemento Marco Lateral

Peso
(Kg/m)
0,244

Perfis De Encaixe:

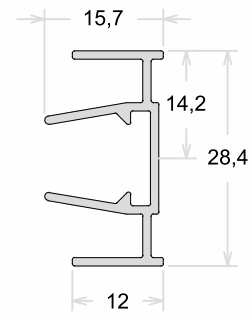

PSU-334

Complemento Marco Lateral

Peso
(Kg/m)
0,332

Perfis De Encaixe:

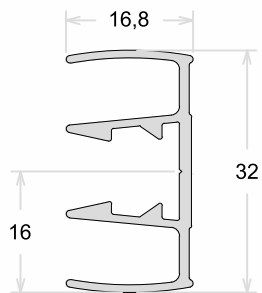

PSU-105

Complemento Folha Central

Peso
(Kg/m)
0,208

Perfis De Encaixe:

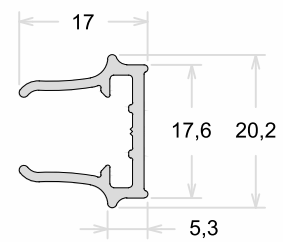

PSU-034	Mata Junta
Peso (Kg/m)	Perfis De Encaixe:
0,335	

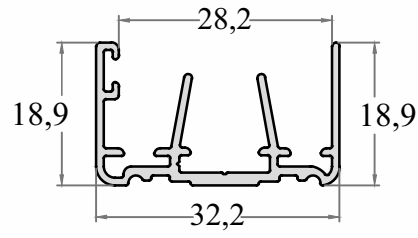

PSU-305	Complemento Folha Central
Peso (Kg/m)	Perfis De Encaixe:
0,268	

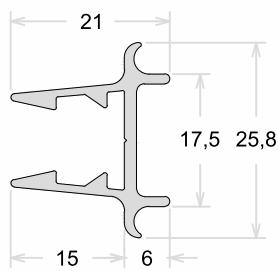

PSU-092	Vedação Montante
Peso (Kg/m)	Perfis De Encaixe:
0,315	

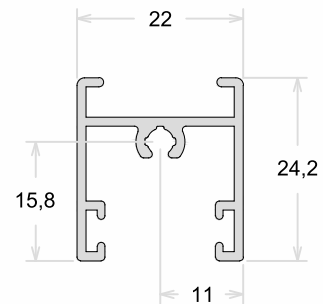

PSU-053	PSU-053S	Folha Horizontal
Peso (Kg/m)	Peso (Kg/m)	Perfis De Encaixe: PSU-102 / PSU-115 / PSU-203
0,443	0,496	

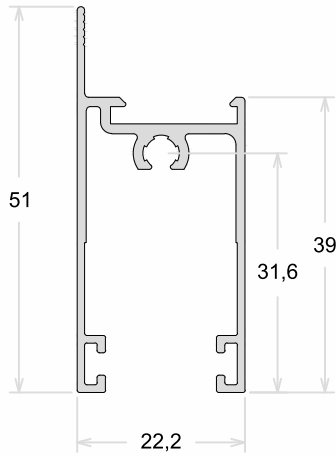

PSU-246	Folha Horizontal
Peso (Kg/m)	Perfis De Encaixe: PSU-102 / PSU-115 / PSU-203
0,678	

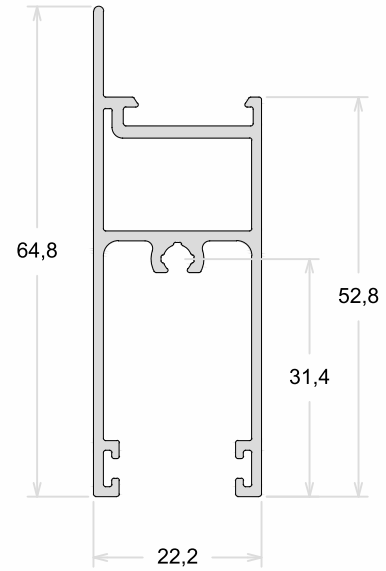

PSU-225	Folha Horizontal
Peso (Kg/m)	Perfis De Encaixe: PSU-102 / PSU-115 / PSU-203
0,966	

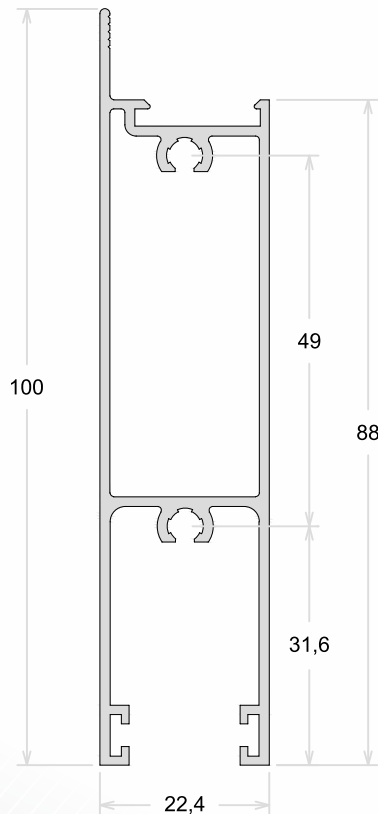

PSU-227	Travessa 57mm
Peso (Kg/m)	Perfis De Encaixe: PSU-102 / PSU-115 / PSU-203
0,543	

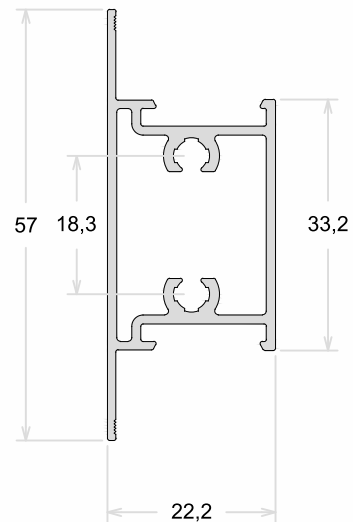

PSU-039	Folha Lateral
Peso (Kg/m)	Perfis De Encaixe: PSU-104 / PSU-116 / PSU-108
0,486	

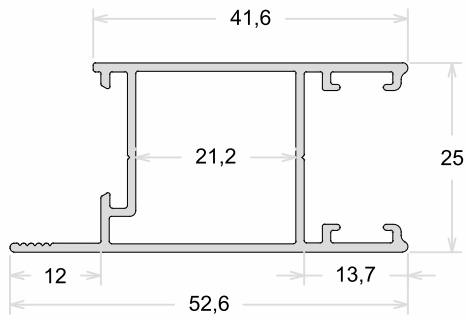

PSU-339	Folha Lateral
Peso (Kg/m)	Perfis De Encaixe: PSU-104 / PSU-116 / PSU-108
0,452	

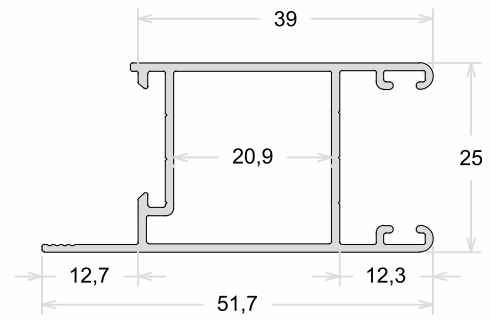

CX-314	Folha Lateral Com Reforço
Peso (Kg/m)	Perfis De Encaixe: PSU-104 / PSU-116 / PSU-108
0,710	

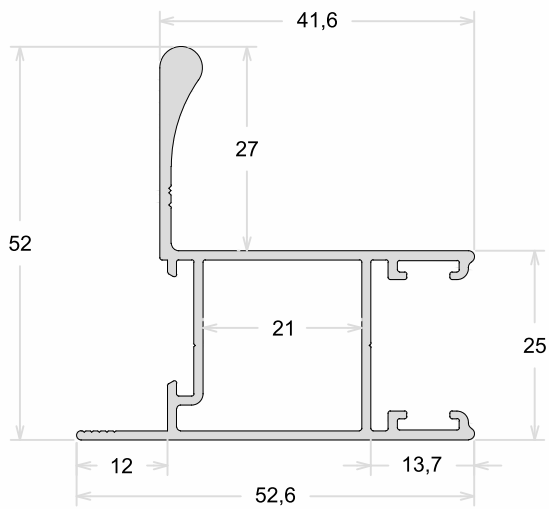

PSU-044	Folha Lateral Com Reforço
Peso (Kg/m)	Perfis De Encaixe: PSU-104 / PSU-116 / PSU-108
0,869	

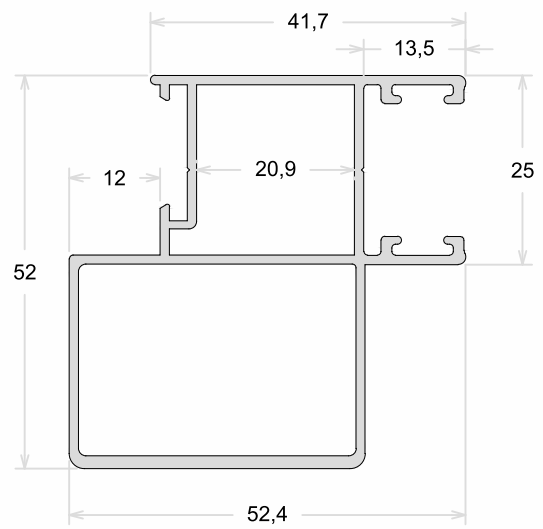

PSU-192	Folha Central
Peso (Kg/m)	Perfis De Encaixe: PSU-104 / PSU-116 / PSU-108
0,480	

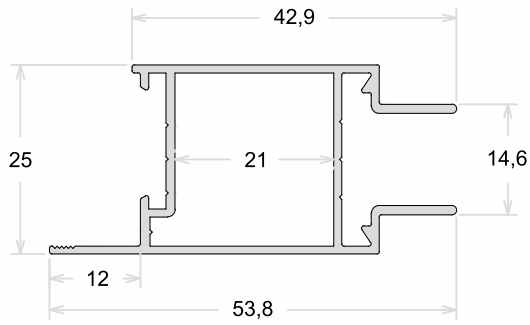

PSU-043	Folha Central Com Reforço
Peso (Kg/m)	Perfis De Encaixe: PSU-104 / PSU-116 / PSU-108
0,866	

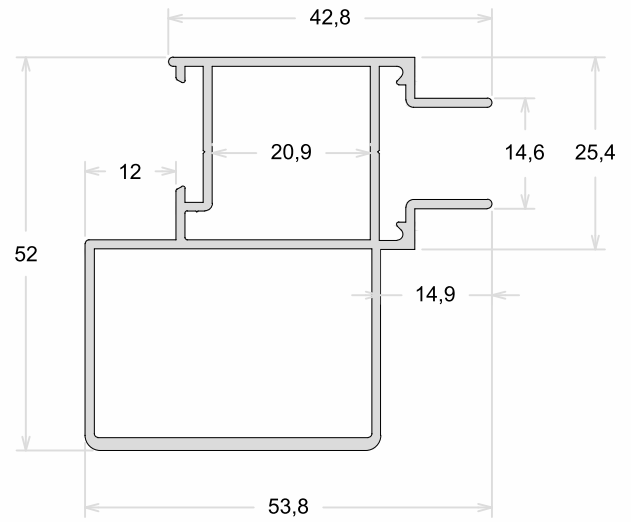

PSU-293	Folha Lateral Para Cremona
Peso (Kg/m)	Perfis De Encaixe: PSU-104 / PSU-116 / PSU-108
0,574	

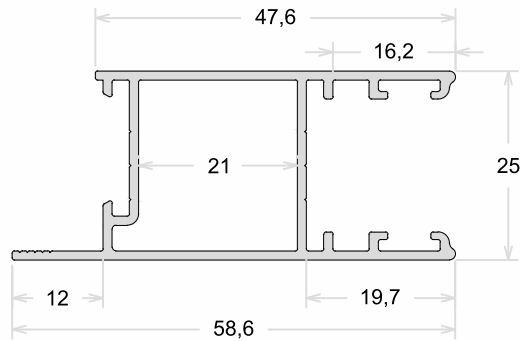

PSU-247	Folha Horizontal
Peso (Kg/m)	Perfis De Encaixe:
1,064	

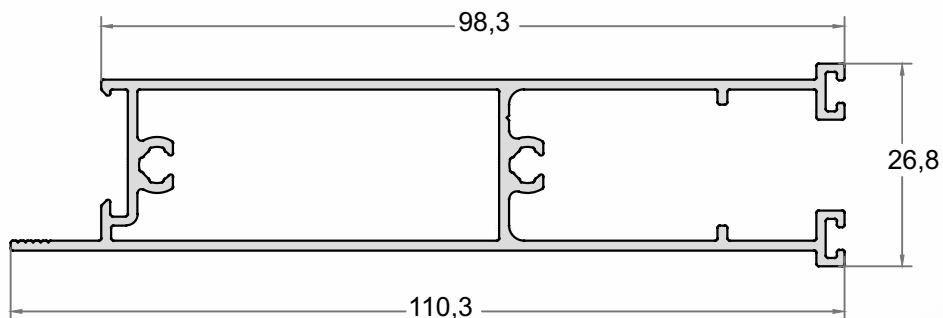

PSU-040 Mão De Amigo Interno

Peso (Kg/m): 0,429

Perfis De Encaixe: PSU-104 / PSU-116 / PSU-108

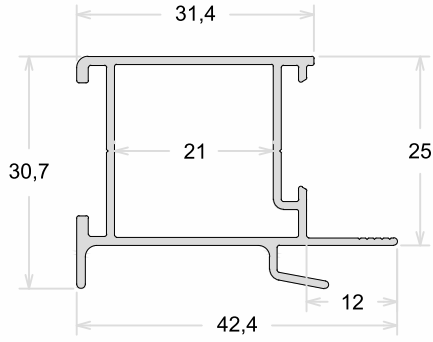

PSU-041 Mão De Amigo Externo

Peso (Kg/m): 0,466

Perfis De Encaixe: PSU-104 / PSU-116 / PSU-108

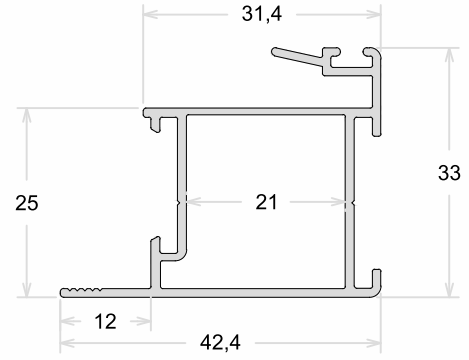

PSU-340 Mão De Amigo Interno

Peso (Kg/m): 0,391

Perfis De Encaixe: PSU-104 / PSU-116 / PSU-108

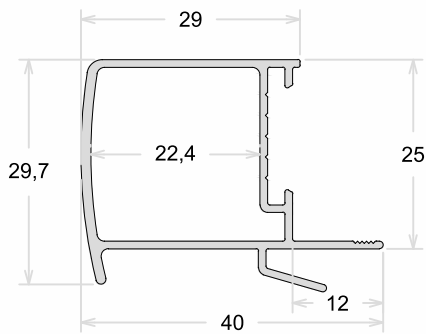

PSU-341 Mão De Amigo Externo

Peso (Kg/m): 0,417

Perfis De Encaixe: PSU-104 / PSU-116 / PSU-108

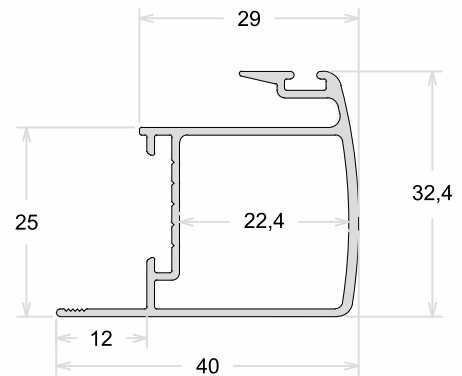

PSU-047	Mão De Amigo Interno Com Reforço
Peso (Kg/m)	Perfis De Encaixe: PSU-104 / PSU-116 / PSU-108
0,958	

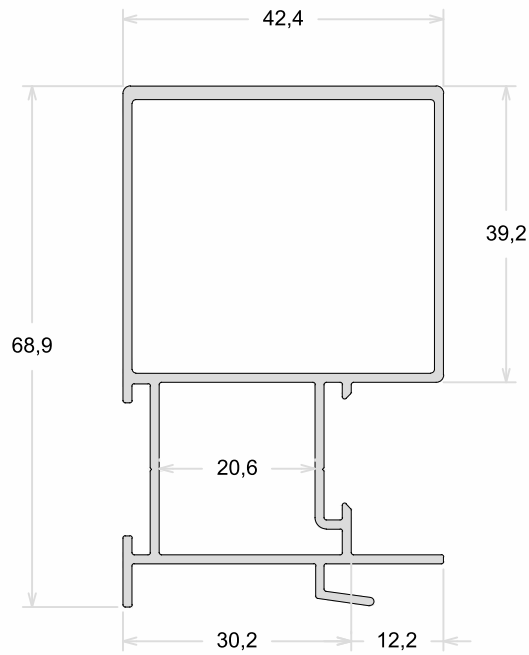

PSU-049	Mão De Amigo Externo Com Reforço
Peso (Kg/m)	Perfis De Encaixe: PSU-104 / PSU-116 / PSU-108
0,866	

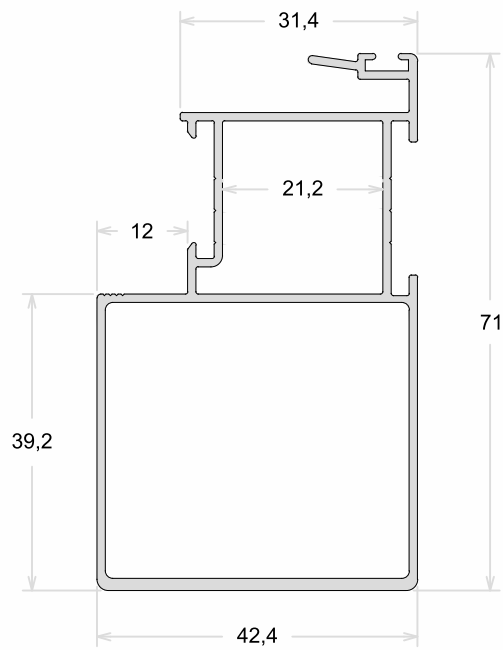

PSU-447 Mão De Amigo Interno
Com Reforço

Peso (Kg/m)
0,664

Perfis De Encaixe:
PSU-104 / PSU-116 / PSU-108

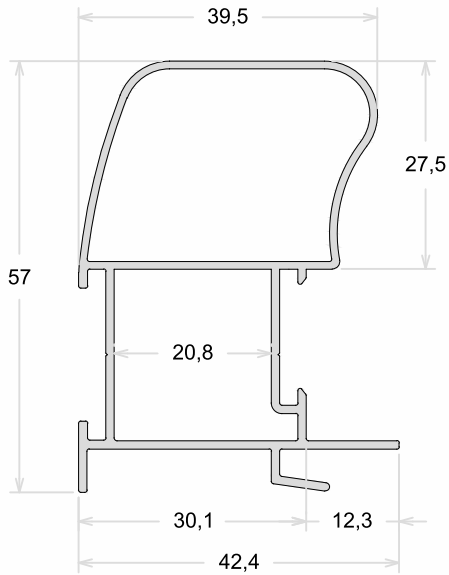

PSU-449 Mão De Amigo Externo
Com Reforço

Peso (Kg/m)
0,670

Perfis De Encaixe:
PSU-104 / PSU-116 / PSU-108

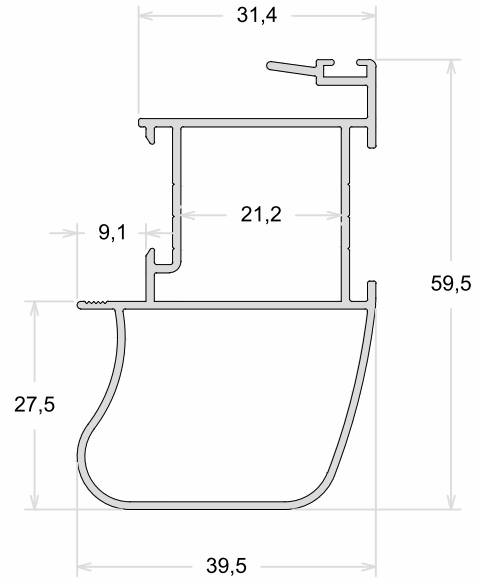

PSU-347 Mão De Amigo Interno
Com Reforço

Peso (Kg/m)
0,635

Perfis De Encaixe:
PSU-104 / PSU-116 / PSU-108

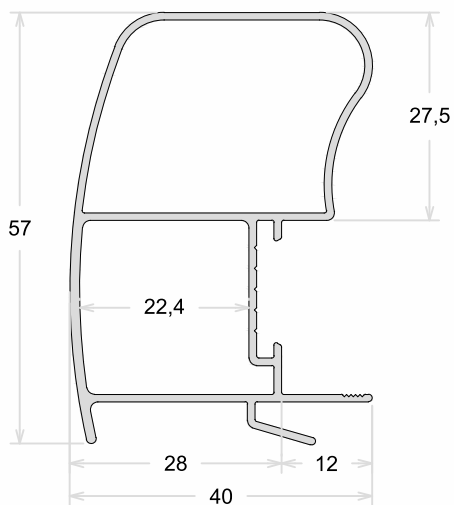

PSU-349 Mão De Amigo Externo
Com Reforço

Peso (Kg/m)
0,646

Perfis De Encaixe:
PSU-104 / PSU-116 / PSU-108

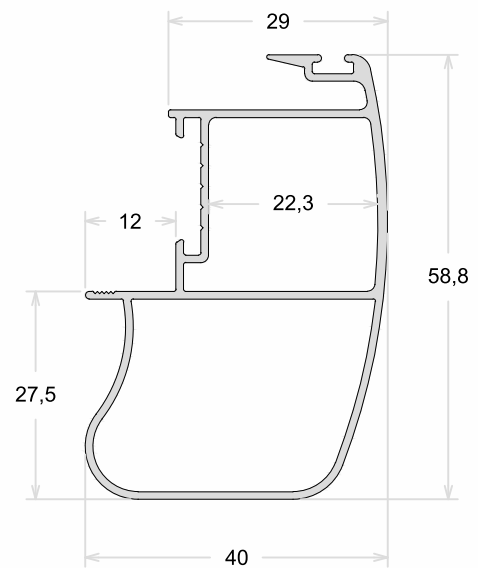

PSU-343 Mão De Amigo Interno Com Reforço

Peso (Kg/m): 0,915

Perfis De Encaixe: PSU-104 / PSU-116 / PSU-108

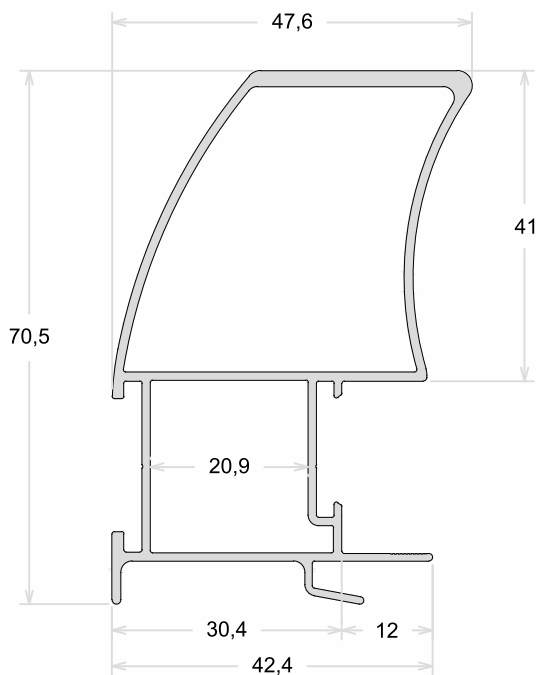

PSU-344 Mão De Amigo Externo Com Reforço

Peso (Kg/m): 0,909

Perfis De Encaixe: PSU-104 / PSU-116 / PSU-108

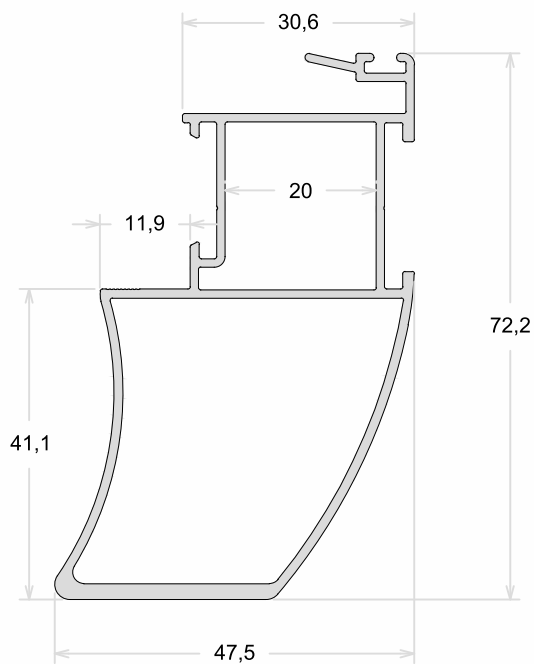

PSU-346 Mão De Amigo Interno Com Reforço

Peso (Kg/m): 0,947

Perfis De Encaixe: PSU-104 / PSU-116 / PSU-108

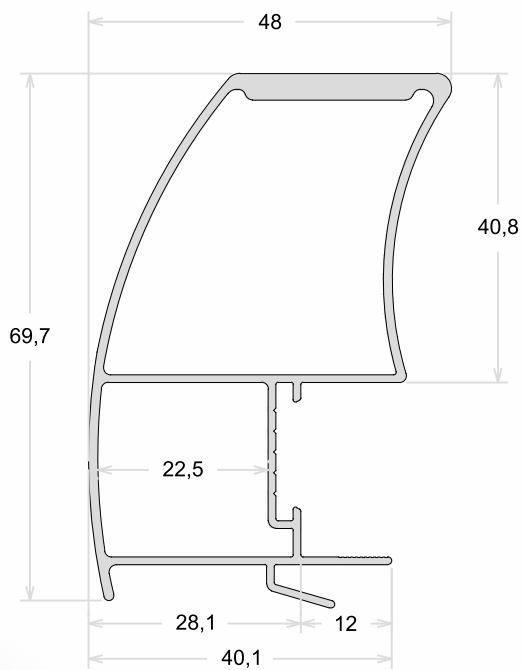

PSU-345 Mão De Amigo Externo Com Reforço

Peso (Kg/m): 0,943

Perfis De Encaixe: PSU-104 / PSU-116 / PSU-108

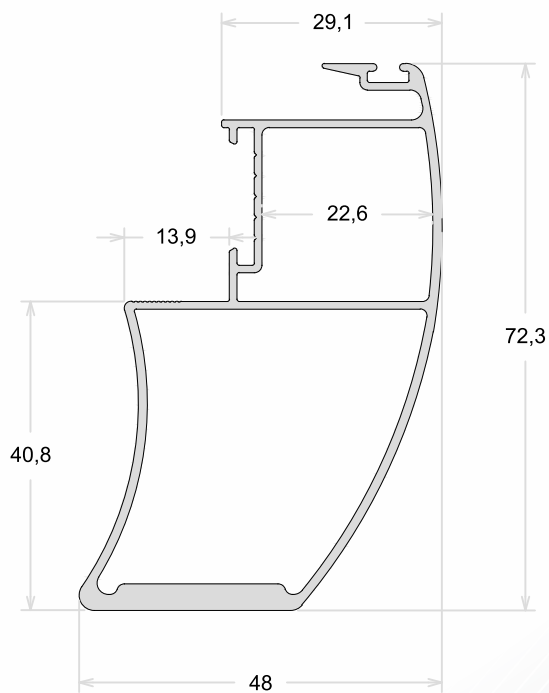

PSU-042	Mão De Amigo Central
Peso (Kg/m)	Perfis De Encaixe: PSU-104 / PSU-116 / PSU-108
0,511	

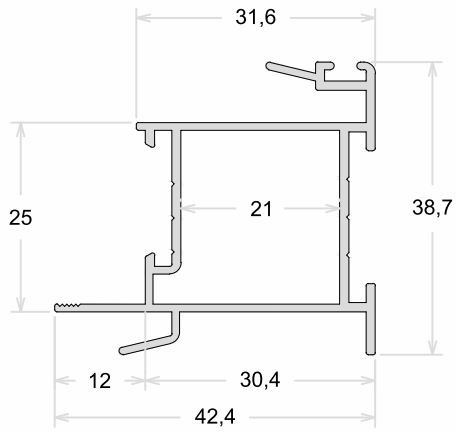

PSU-342	Mão De Amigo Central
Peso (Kg/m)	Perfis De Encaixe: PSU-104 / PSU-116 / PSU-108
0,448	

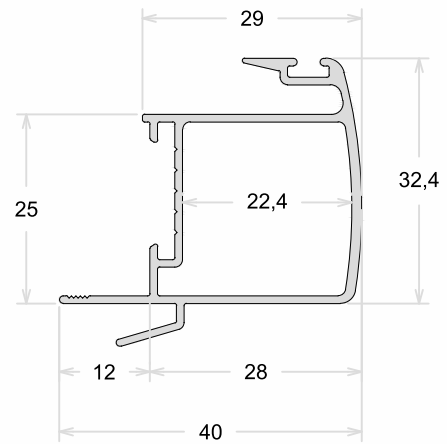

PSU-038	Folha 90°
Peso (Kg/m)	Perfis De Encaixe:
0,527	

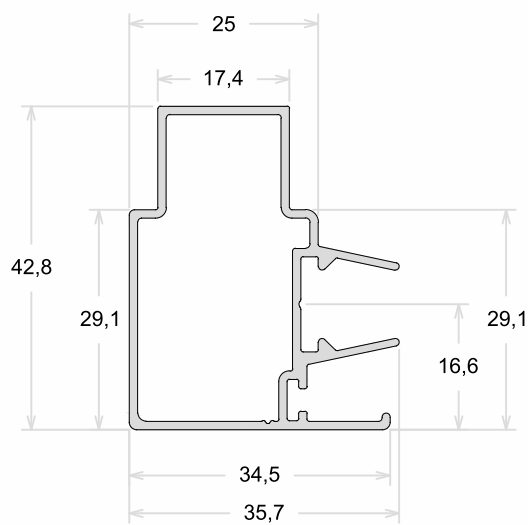

PSU-245 Folha Lateral

Peso (Kg/m): 0,636

Perfis De Encaixe: PSU-104 / PSU-116 / PSU-108

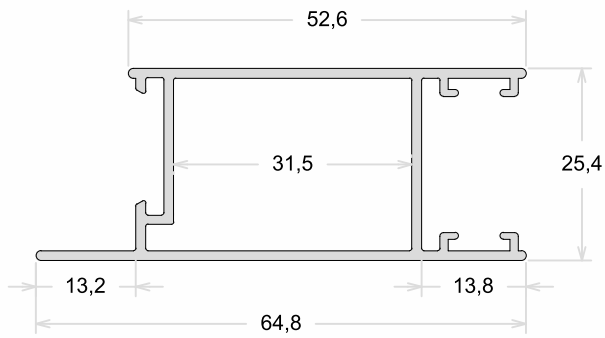

PSU-280 Folha Lateral Com Reforço

Peso (Kg/m): 0,874

Perfis De Encaixe: PSU-104 / PSU-116 / PSU-108

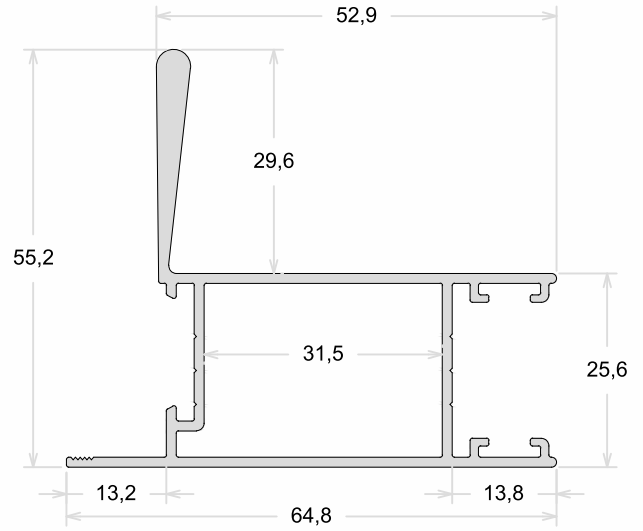

PSU-299 Folha Lateral Com Reforço

Peso (Kg/m): 0,966

Perfis De Encaixe: PSU-104 / PSU-116 / PSU-108

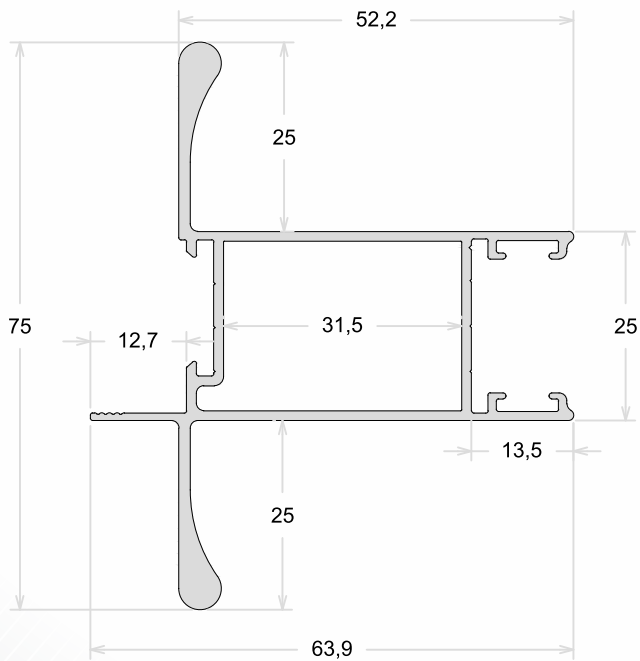

PSU-380 Folha Lateral Com Reforço

Peso (Kg/m): 0,721

Perfis De Encaixe: PSU-104 / PSU-116 / PSU-108

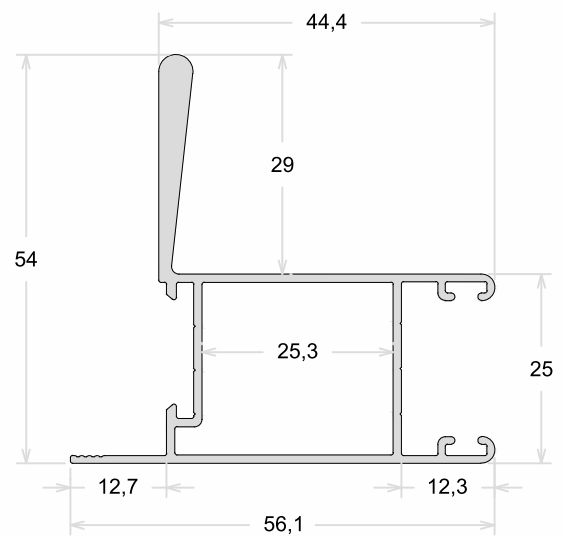

PSU-243

Mão De Amigo Interno

Peso
(Kg/m)

0,670

Perfis De Encaixe:
PSU-104 / PSU-116 / PSU-108

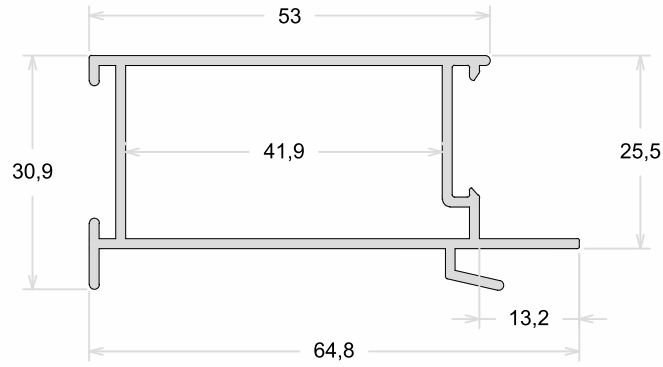

PSU-242

Mão De Amigo Externo

Peso
(Kg/m)

0,699

Perfis De Encaixe:
PSU-104 / PSU-116 / PSU-108

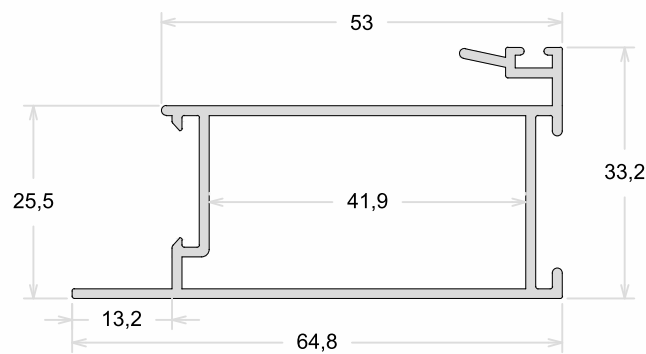

PSU-354	Folha Lateral Vertical
Peso (Kg/m)	Perfis De Encaixe: PSU-104 / PSU-116 / PSU-108
0,759	

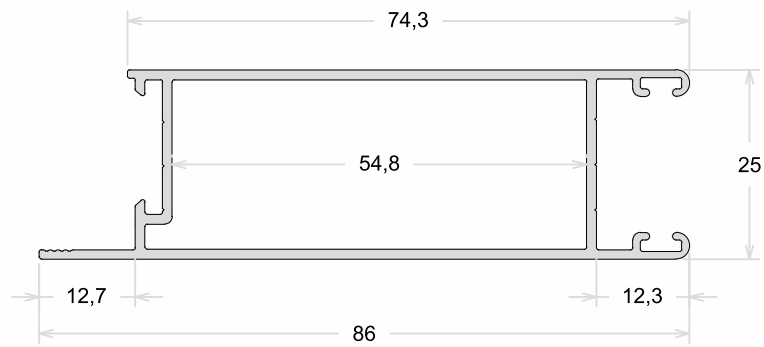

PSU-351	Mão De Amigo Central
Peso (Kg/m)	Perfis De Encaixe: PSU-104 / PSU-116 / PSU-108
0,860	

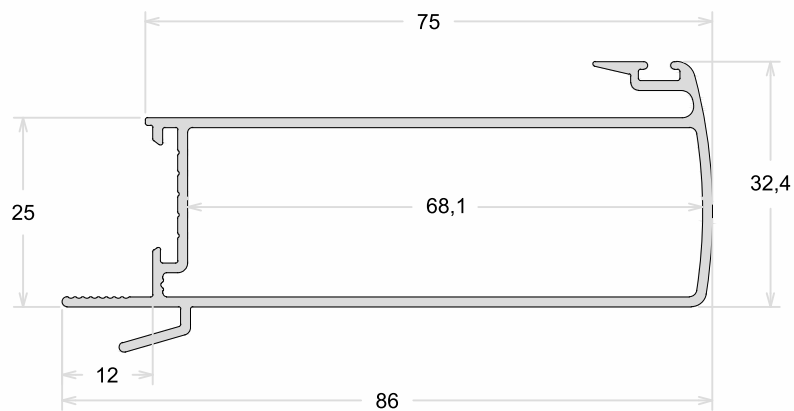

PSU-353	Mão De Amigo Interno
Peso (Kg/m)	Perfis De Encaixe: PSU-104 / PSU-116 / PSU-108
0,855	

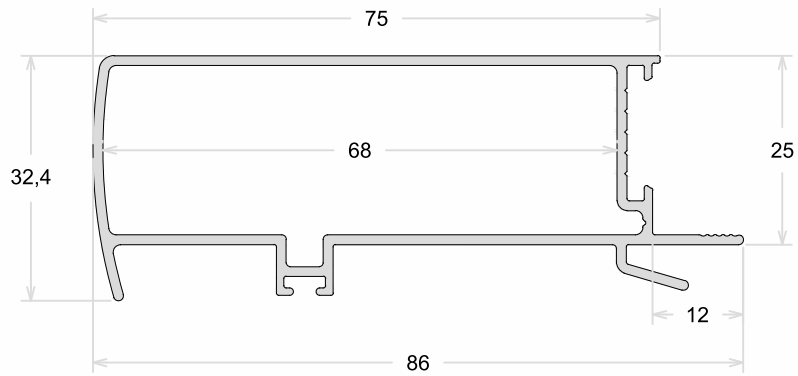

PSU-352	Mão De Amigo Externo
Peso (Kg/m)	Perfis De Encaixe: PSU-104 / PSU-116 / PSU-108
0,818	

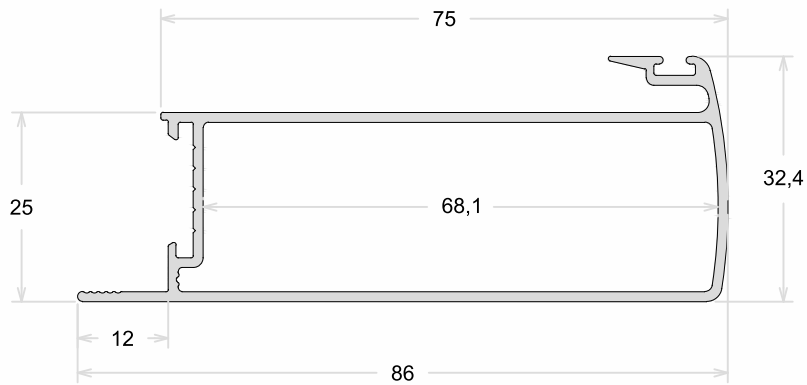

PSU-239	Mão de Amigo sem Baguete
Peso (Kg/m)	Perfis De Encaixe:
0,804	

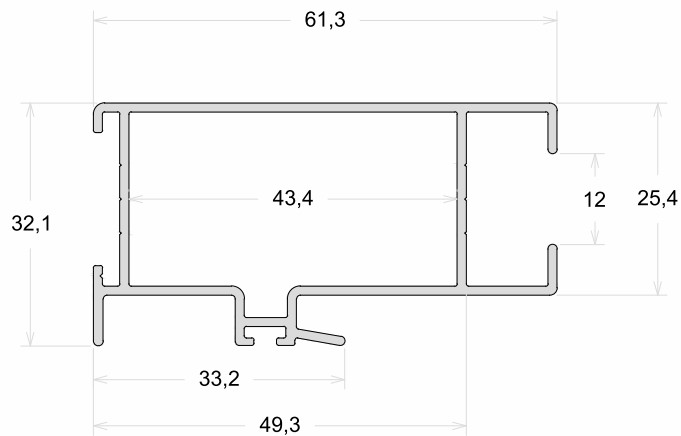

PSU-186	PSU-186S	Folha Horizontal - S/ Baguele
Peso (Kg/m)	Peso (Kg/m)	Perfis De Encaixe:
0,444	0,487	

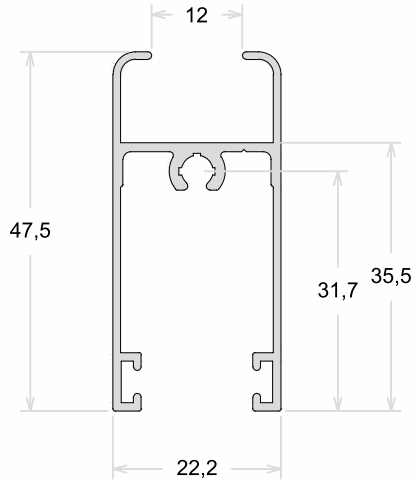

PSU-188	PSU-188S	Travessa 50mm - S/ Baguele
Peso (Kg/m)	Peso (Kg/m)	Perfis De Encaixe:
0,548	0,587	

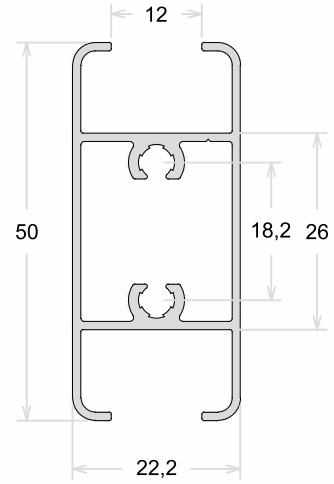

PSU-226	Folha Horizontal - S/ Baguele
Peso (Kg/m)	Perfis De Encaixe:
0,983	

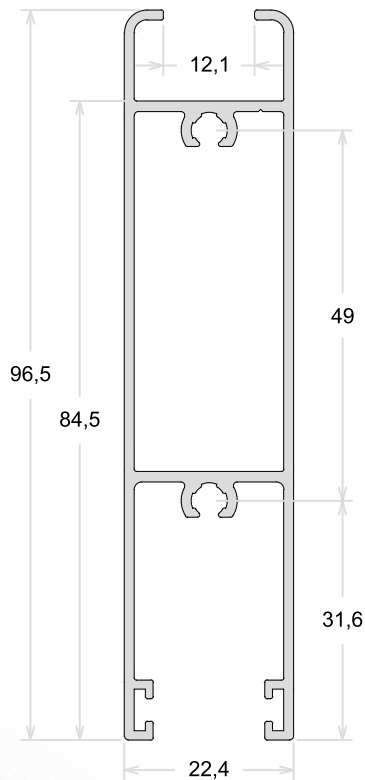

PSU-057	Mão De Amigo Central Sem Baguele
Peso (Kg/m)	Perfis De Encaixe:
0,588	

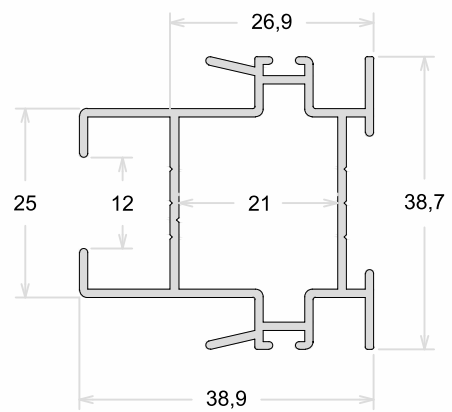

PSU-055 Folha Lateral - S/ Bagueete

Peso (Kg/m): 0,503

Perfis De Encaixe:

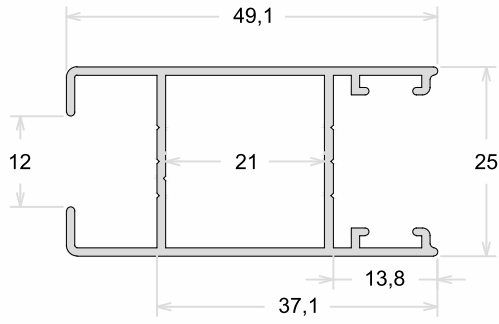

PSU-238 Folha Lateral - S/ Bagueete

Peso (Kg/m): 0,625

Perfis De Encaixe:

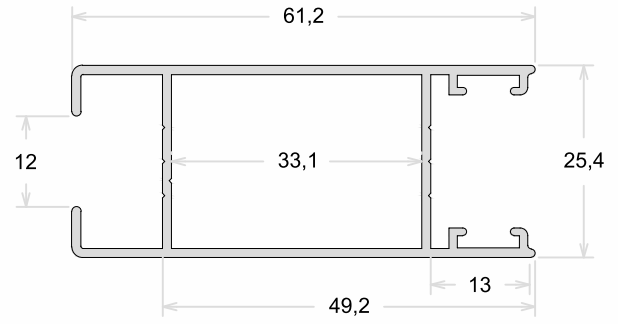

PSU-061 Mão De Amigo Com Reforço Sem Bagueete

Peso (Kg/m): 0,974

Perfis De Encaixe:

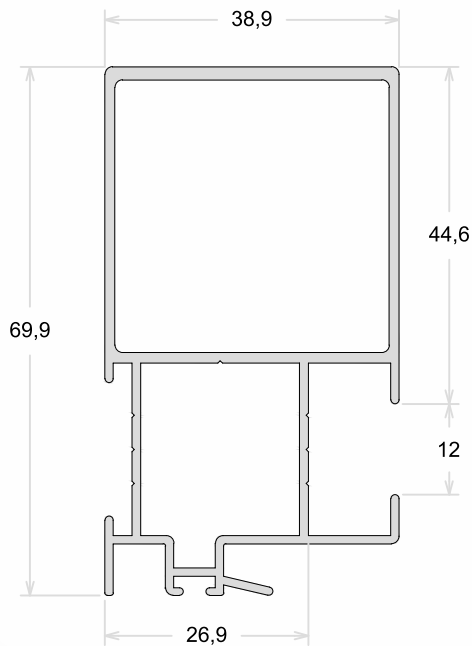

PSU-056 Mão De Amigo - S/ Bagueete

Peso (Kg/m): 0,501

Perfis De Encaixe:

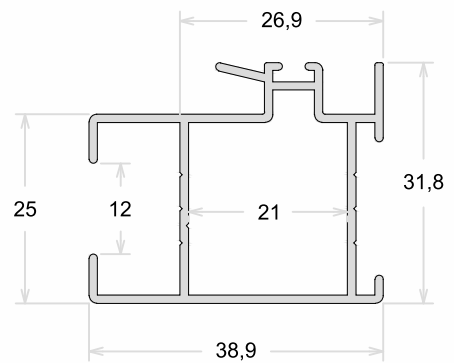

PSU-068 Folha Lateral - Veneziana
Peso (Kg/m): 0,525
Perfis De Encaixe:

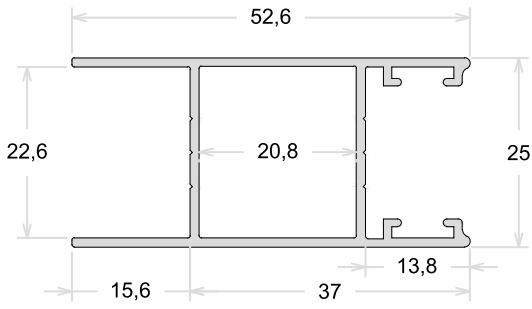

PSU-232 Folha Central - Veneziana
Peso (Kg/m): 0,449
Perfis De Encaixe:

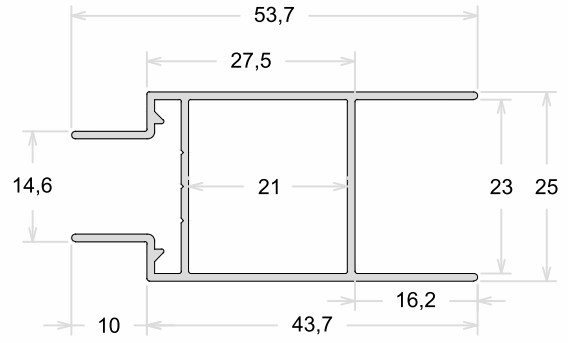

PSU-070 Mão De Amigo - Veneziana
Peso (Kg/m): 0,458
Perfis De Encaixe:

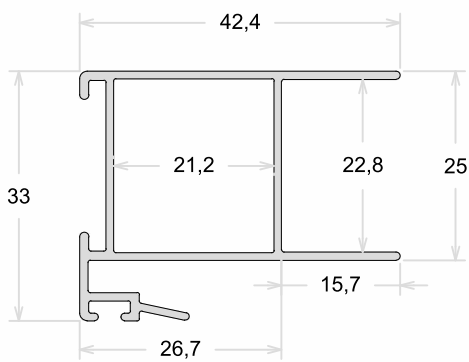

PSU-069 Mão De Amigo Central Veneziana
Peso (Kg/m): 0,521
Perfis De Encaixe:

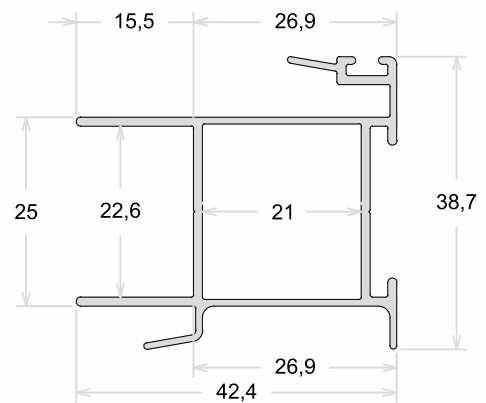

PSU-187	Folha Horizontal - Veneziana
Peso (Kg/m)	Perfis De Encaixe:
0,452	

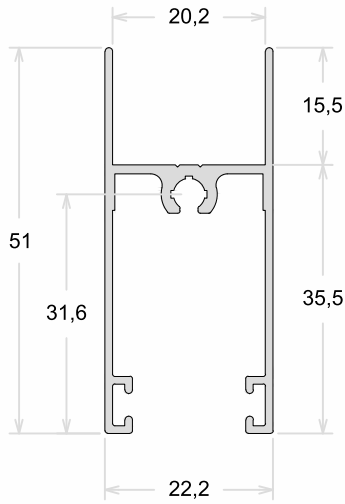

PSU-368	Folha Lateral - Veneziana
Peso (Kg/m)	Perfis De Encaixe:
0,469	

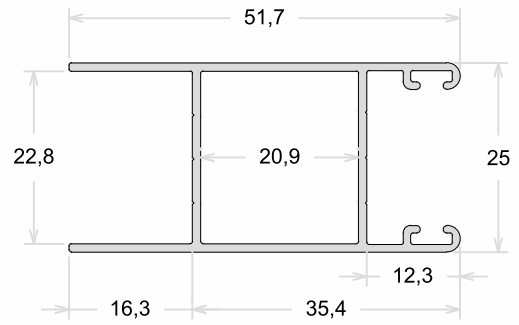

PSU-370	Mão De Amigo - Veneziana
Peso (Kg/m)	Perfis De Encaixe:
0,428	

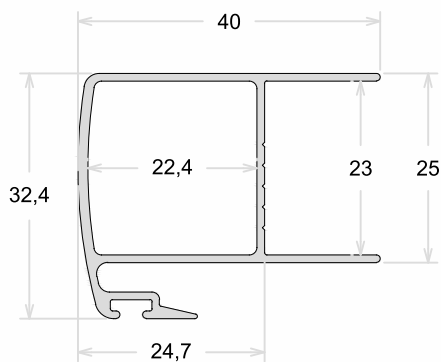

PSU-369	Mão De Amigo Central Veneziana
Peso (Kg/m)	Perfis De Encaixe:
0,459	

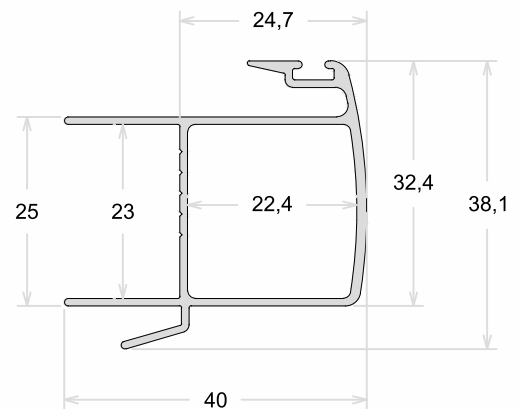

PU-038	Trilho Inferior
Peso (Kg/m)	Perfis De Encaixe:
0,136	

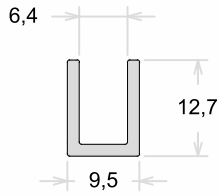

PSU-117	Trilho Inferior
Peso (Kg/m)	Perfis De Encaixe:
0,277	

Trilho também utilizavel na linha 32

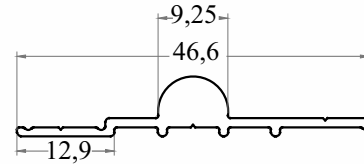

PSU-113	Trilho Inferior
Peso (Kg/m)	Perfis De Encaixe:
0,231	

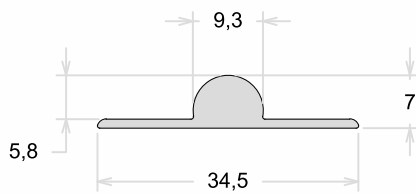

PSU-114	Trilho Inferior
Peso (Kg/m)	Perfis De Encaixe:
0,169	

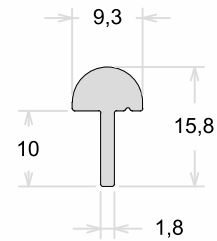

PIT-001	Marco Superior
Peso (Kg/m)	Perfis De Encaixe: PIT-007 / PIT-015 / PIT-006 / PIT-016 PIT-110 / PIT-010 / PIT-010F
0,696	

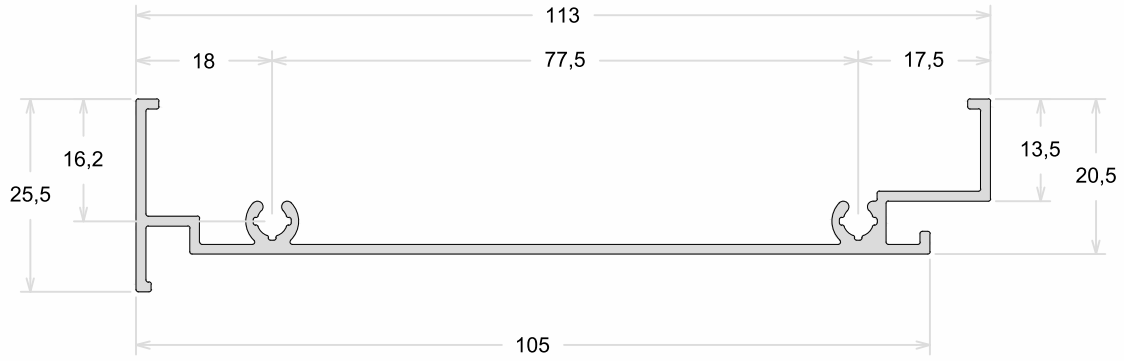

PIT-002	Travessa Intermediária
Peso (Kg/m)	Perfis De Encaixe: PIT-006 / PIT-016 / PIT-110 / PIT-010 PIT-010F
0,775	

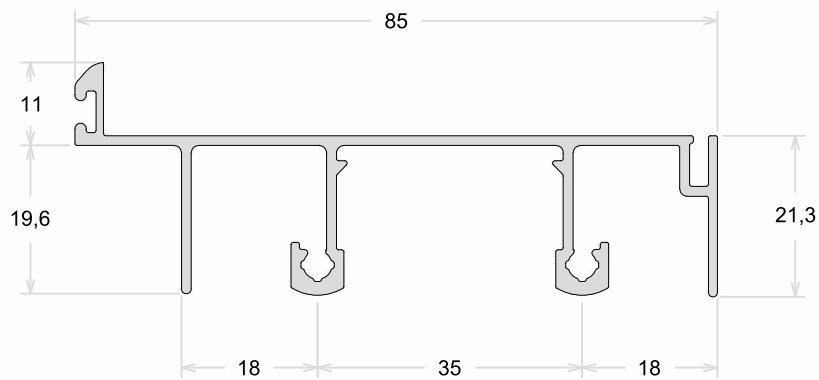

PIT-020	Travessa Intermediária
Peso (Kg/m)	Perfis De Encaixe: PIT-006 / PIT-016 / PIT-110 / PIT-010
1,174	PIT-010F

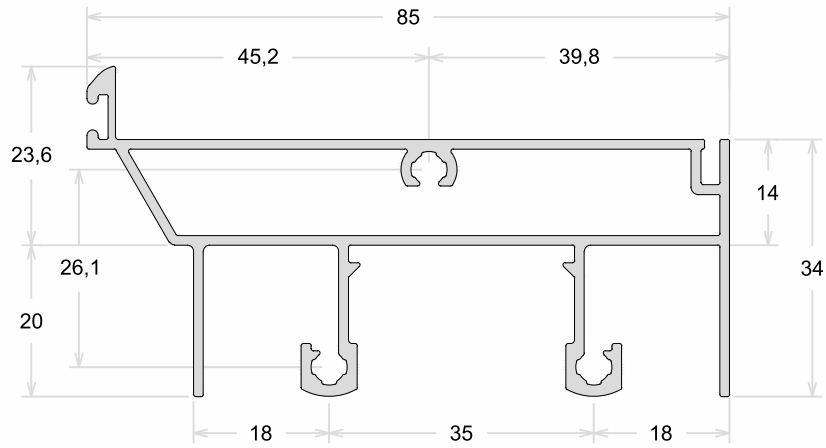

PIT-003	Marco Inferior
Peso (Kg/m)	Perfis De Encaixe: PIT-010 / PIT-010F
0,923	

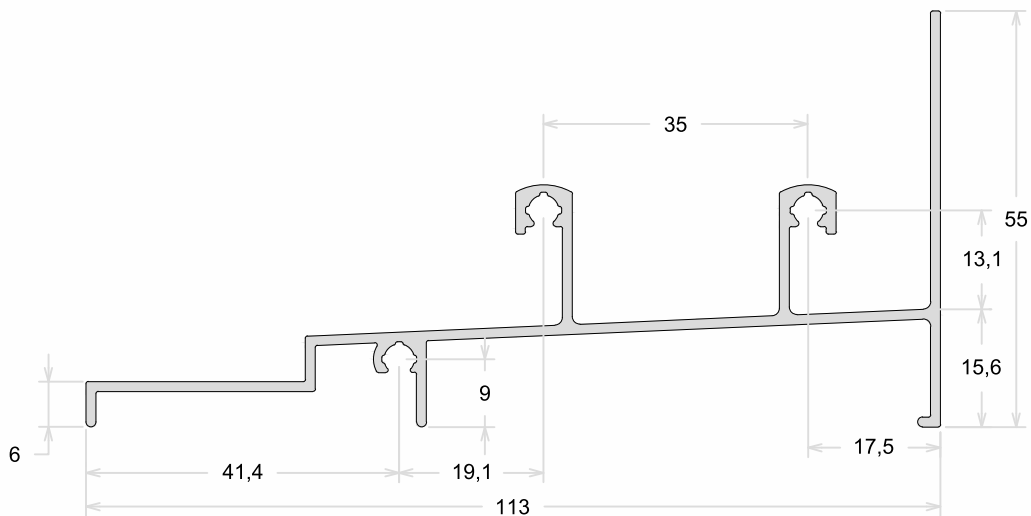

PIT-010	Marco Lateral
Peso (Kg/m)	Perfis De Encaixe:
0,536	

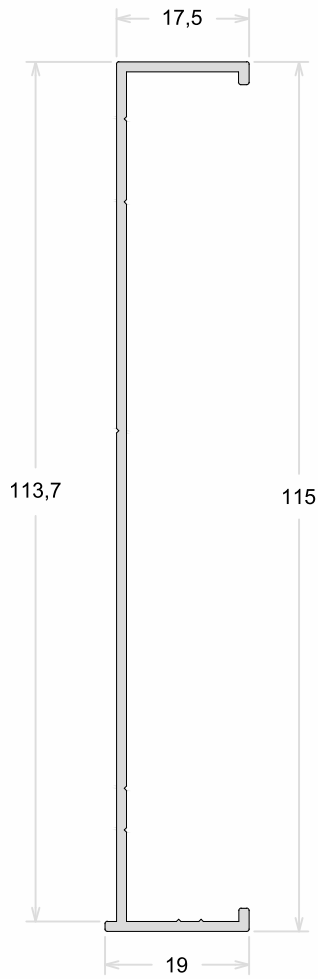

PIT-010F	Marco Lateral
Peso (Kg/m)	Perfis De Encaixe:
0,544	

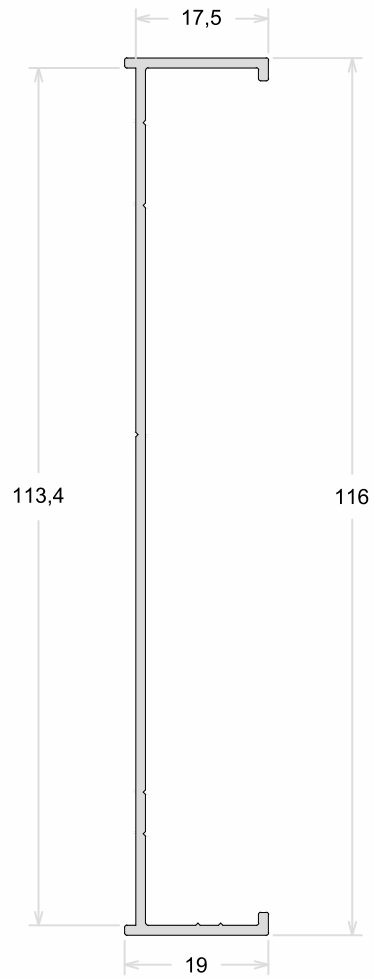

PIT-017	Travessa Intermediária
Peso (Kg/m)	Perfis De Encaixe:
0,485	

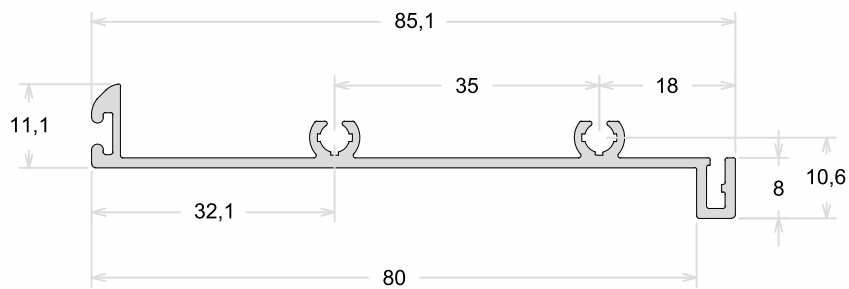

PIT-004	Marco Lateral
Peso (Kg/m)	Perfis De Encaixe:
0,948	

PIT-005	Guia Da Persiana
Peso (Kg/m)	Perfis De Encaixe:
0,647	

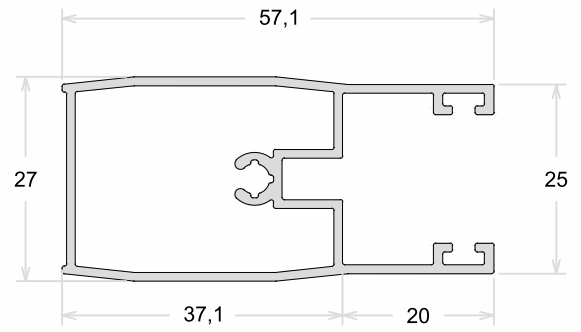
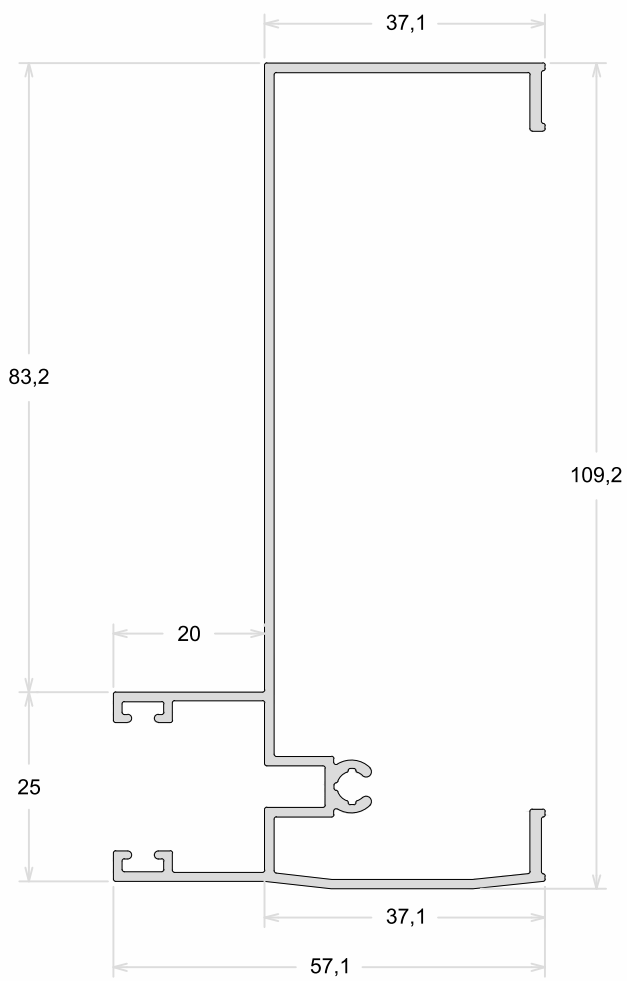

PIT-018	Guia Duplo Da Persiana
Peso (Kg/m)	Perfis De Encaixe:
0,892	

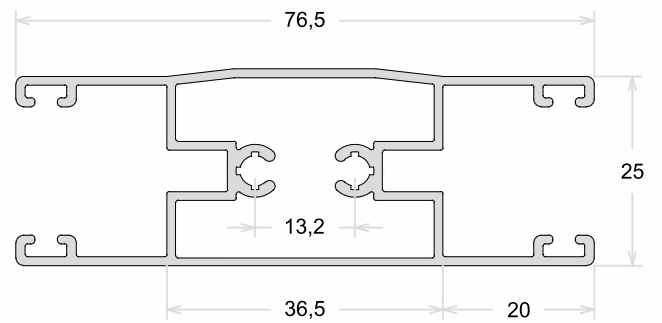

PIT-100	Marco Superior
Peso (Kg/m)	Perfis De Encaixe:
0,814	PIT-007 / PIT-015 / PIT-006 / PIT-016 PIT-110 / PLG-170 / PMN-003

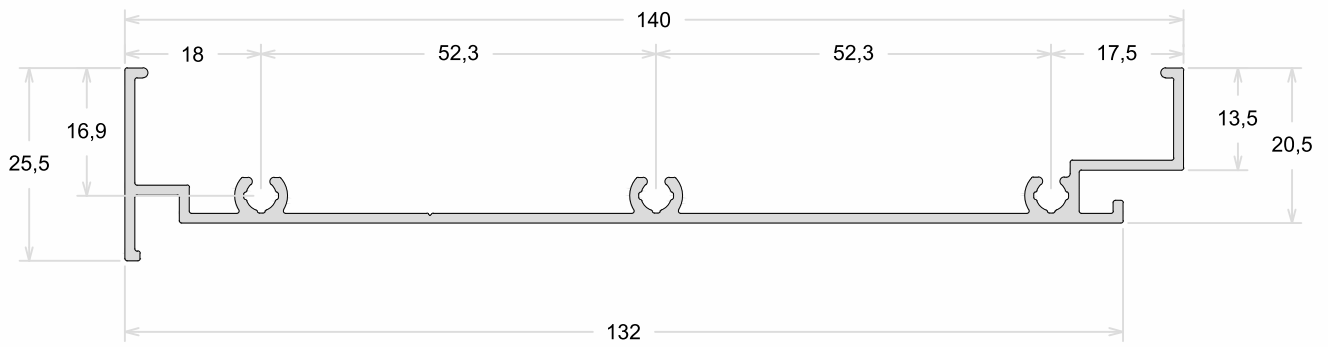

PIT-101	Travessa Intermediária
Peso (Kg/m)	Perfis De Encaixe:
1,486	PIT-006 / PIT-016 / PIT-110 / PLG-170 PMN-003

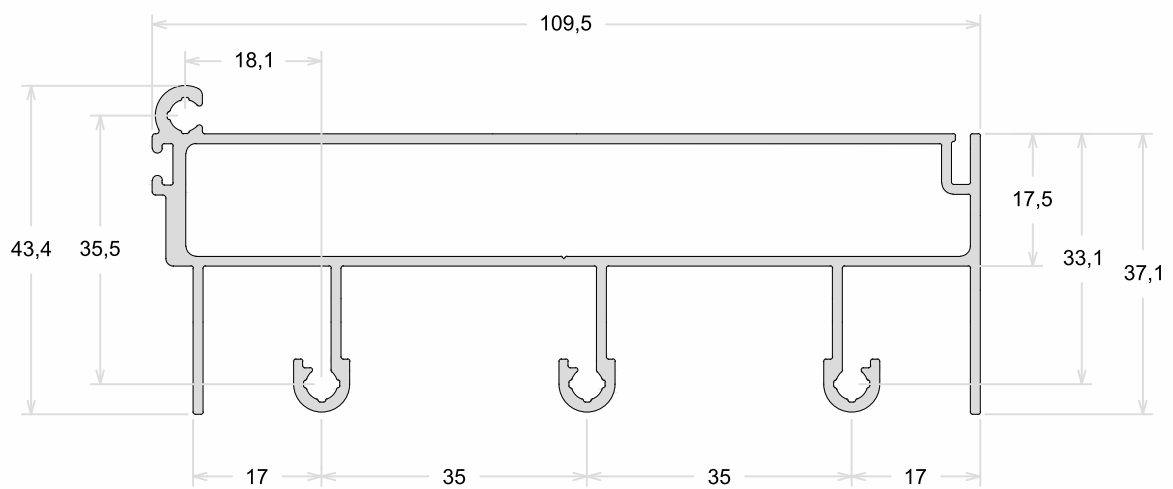

PIT-177	Marco Inferior
Peso (Kg/m)	Perfis De Encaixe: PLG-170 / PMN-003
1,324	

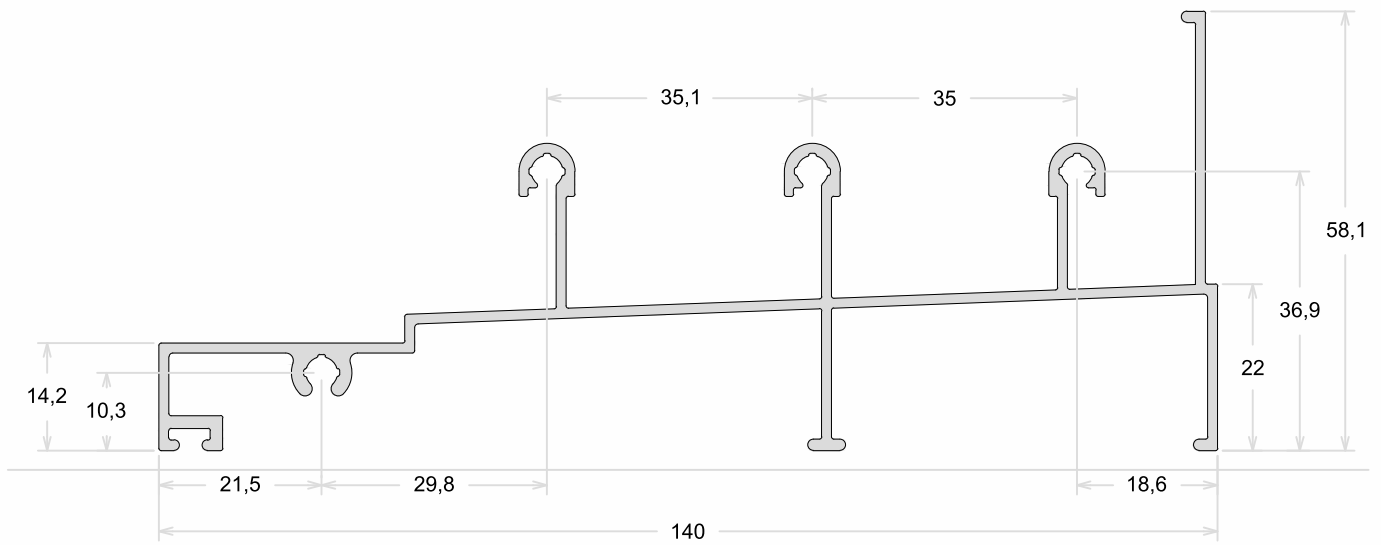

PMN-003	Marco Lateral
Peso (Kg/m)	Perfis De Encaixe:
0,991	

PLG-170	Marco Lateral
Peso (Kg/m)	Perfis De Encaixe:
0,746	

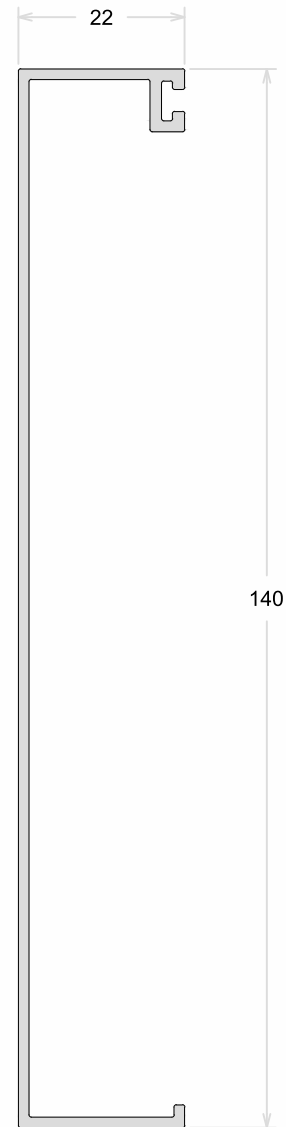
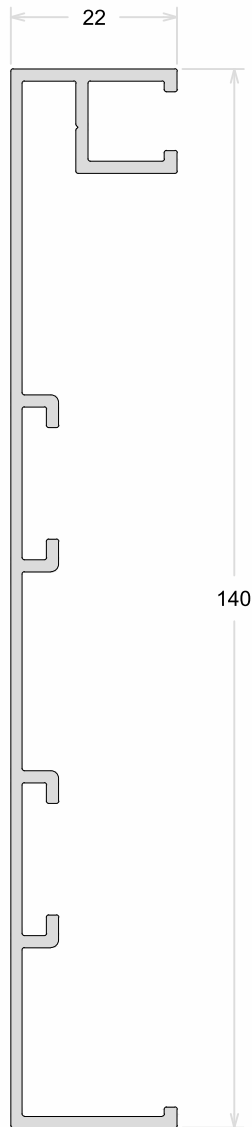

PMN-050	Marco Lateral
Peso (Kg/m)	Perfis De Encaixe:
0,651	

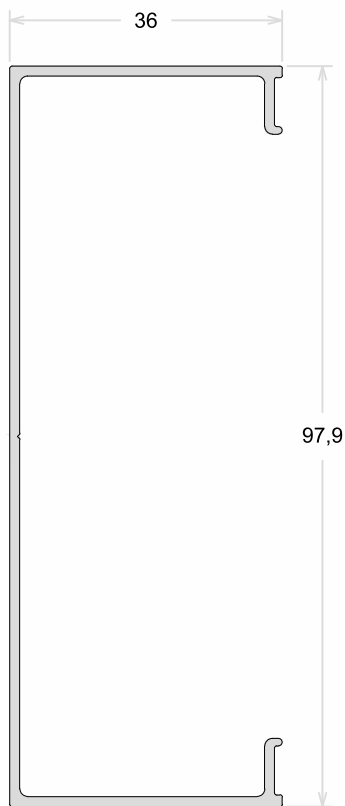

PLG-236	Marco Lateral
Peso (Kg/m)	Perfis De Encaixe:
1,185	

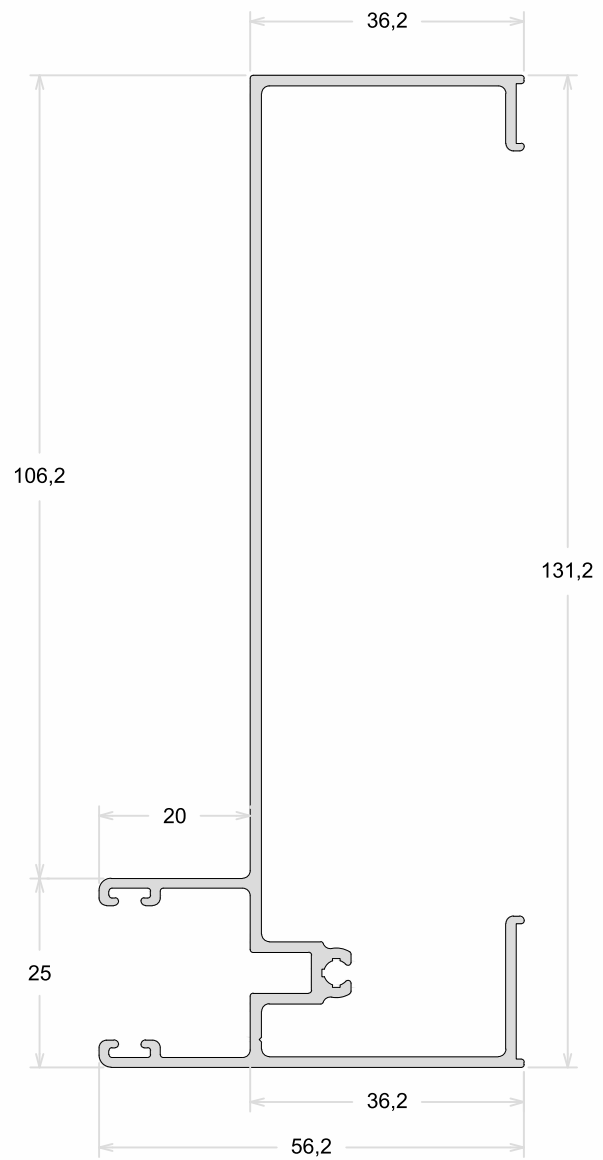

PIT-019	Tampa Interna
Peso (Kg/m)	Perfis De Encaixe: PIT-001 / PIT-002 / PIT-017 PIT-020 / PIT-100 / PIT-101
0,973	

PIT-006	Tampa Interna
Peso (Kg/m)	Perfis De Encaixe: PIT-001 / PIT-002 / PIT-017 PIT-020 / PIT-100 / PIT-101
0,827	

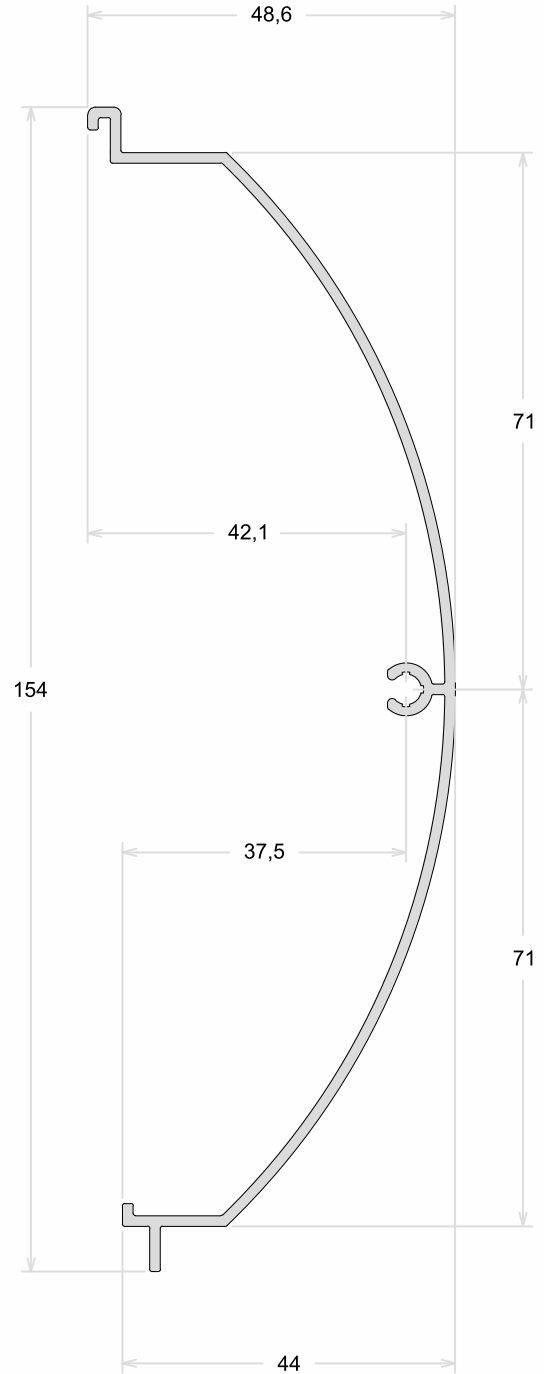
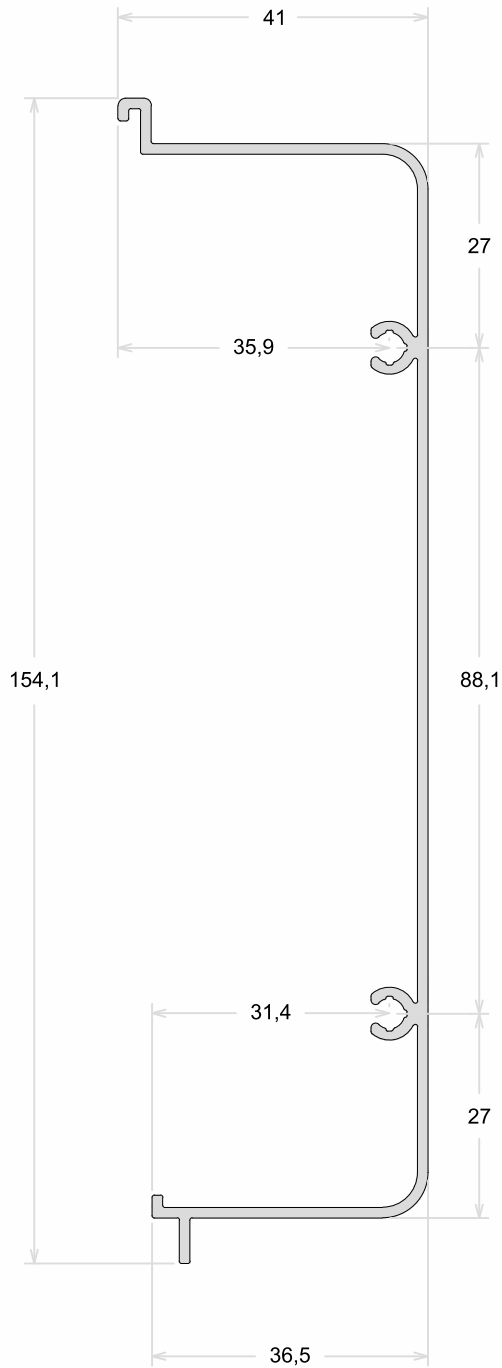

PIT-016	Tampa Interna
Peso (Kg/m)	Perfis De Encaixe: PIT-001 / PIT-002 / PIT-017 PIT-020 / PIT-100 / PIT-101
1,290	



PIT-110	Tampa Interna
Peso (Kg/m)	Perfis De Encaixe: PIT-001 / PIT-002 / PIT-017 PIT-020 / PIT-100 / PIT-101
1,391	



PIT-007	Tampa Externa
Peso (Kg/m)	Perfis De Encaixe: PIT-001 / PIT-100
0,733	

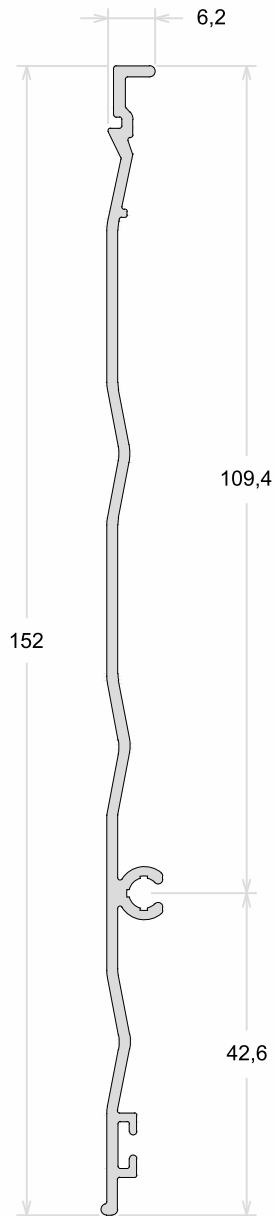

PIT-015	Tampa Externa
Peso (Kg/m)	Perfis De Encaixe: PIT-001 / PIT-100
1,009	

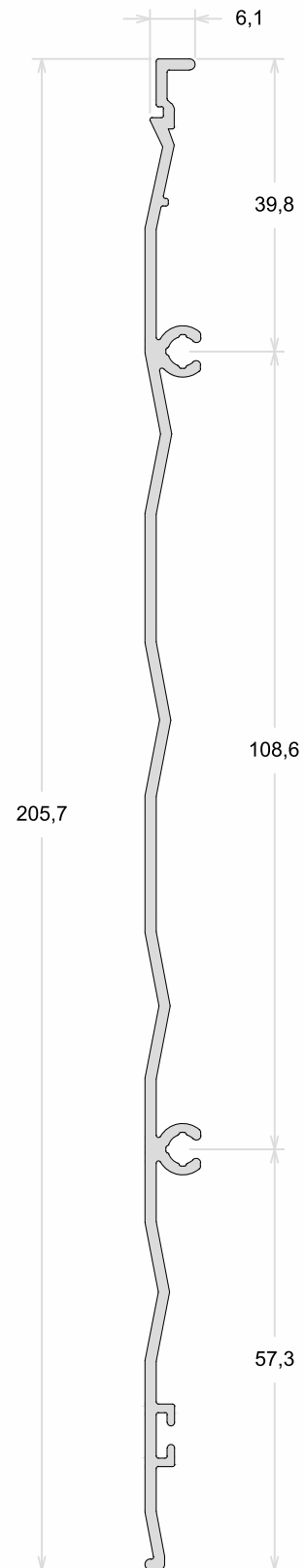

PIT-022	Marco Superior
Peso (Kg/m)	Perfis De Encaixe: PIT-023 / PIT-024 / PMH-008
0,686	PIT-039 / PIT-010 / PIT-010F

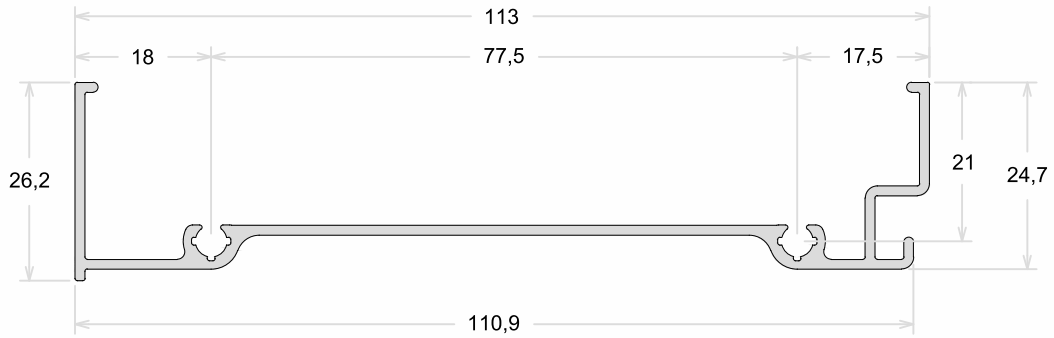

PIT-003	Marco Inferior
Peso (Kg/m)	Perfis De Encaixe: PIT-010 / PIT-010F
0,923	

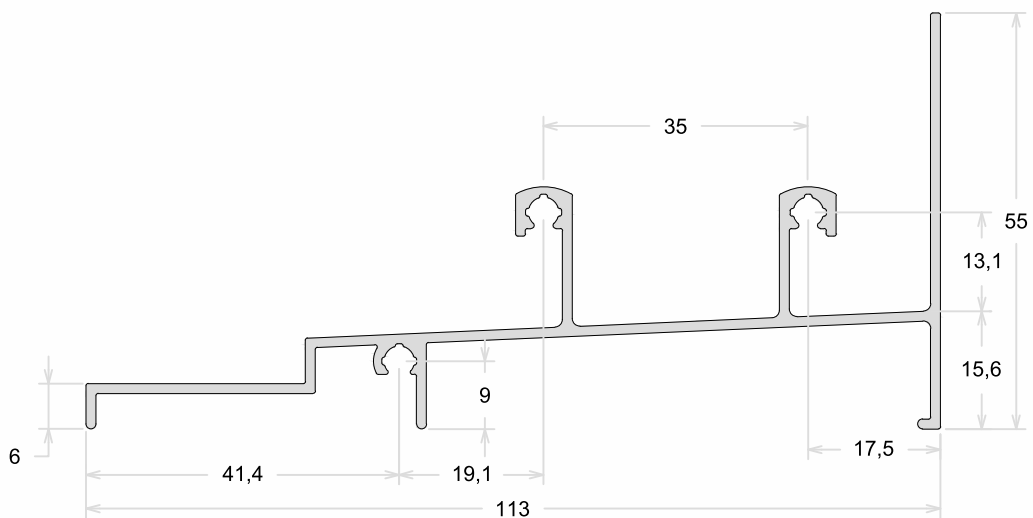

PIT-026	Travessa Intermediária
Peso (Kg/m)	Perfis De Encaixe: PIT-023 / PIT-024
0,794	

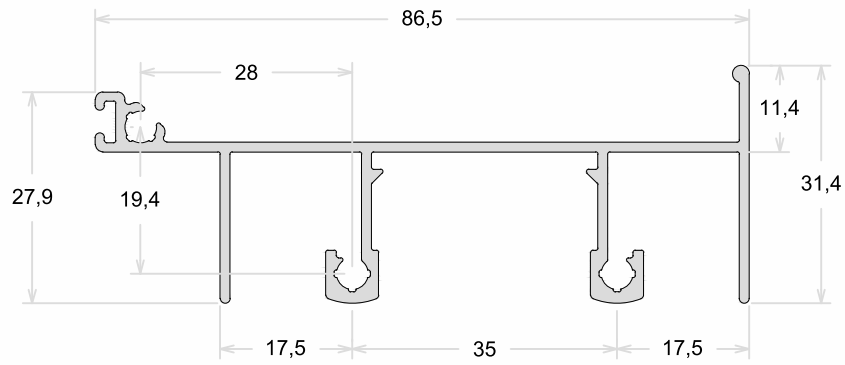

PIT-025	Travessa Intermediária
Peso (Kg/m)	Perfis De Encaixe: PIT-023 / PIT-024
1,181	

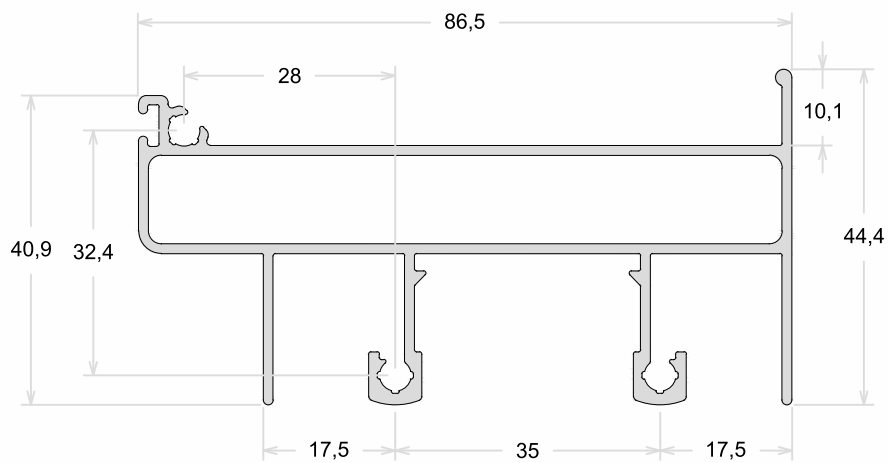

PIT-010	Marco Lateral
Peso (Kg/m)	Perfis De Encaixe:
0,536	

PIT-010F	Marco Lateral
Peso (Kg/m)	Perfis De Encaixe:
0,544	

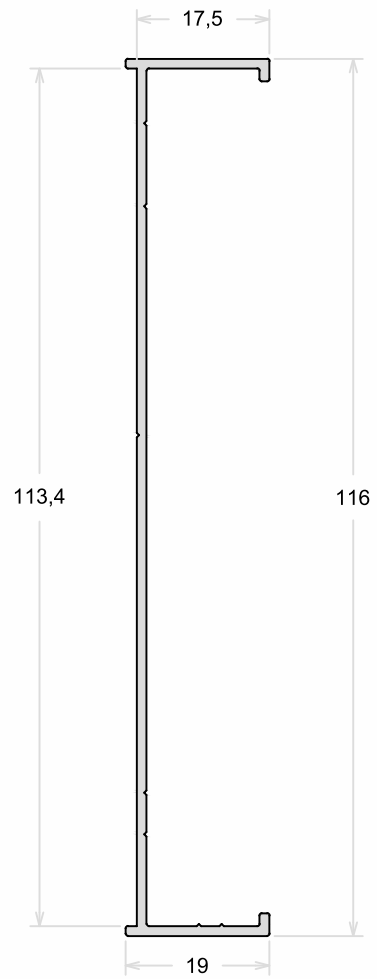
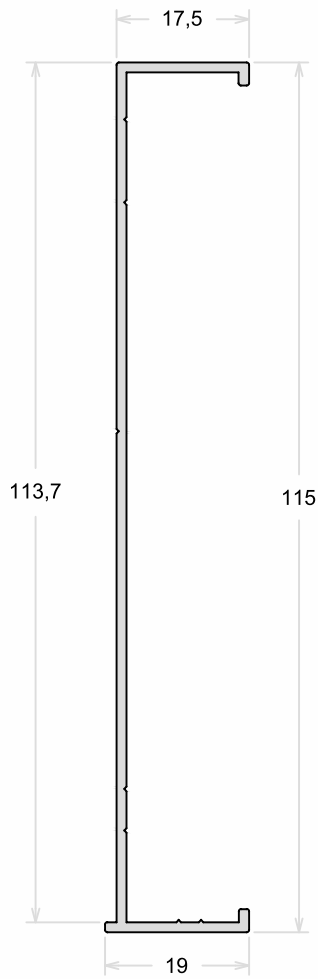

PIT-004	Marco Lateral
Peso (Kg/m)	Perfis De Encaixe:
0,948	

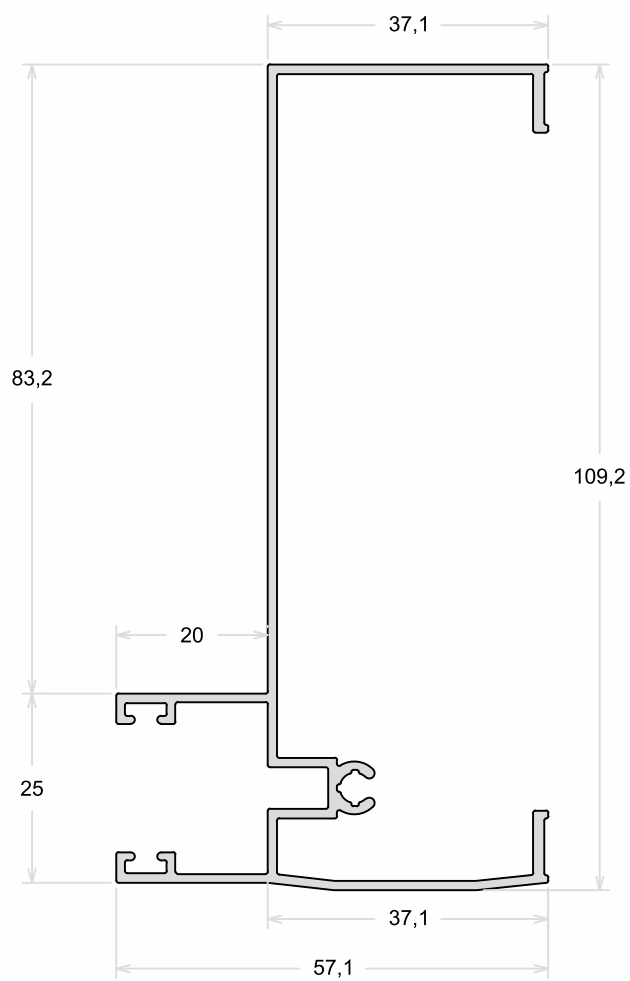

PIT-178	Marco Superior
Peso (Kg/m)	Perfis De Encaixe:
1,070	

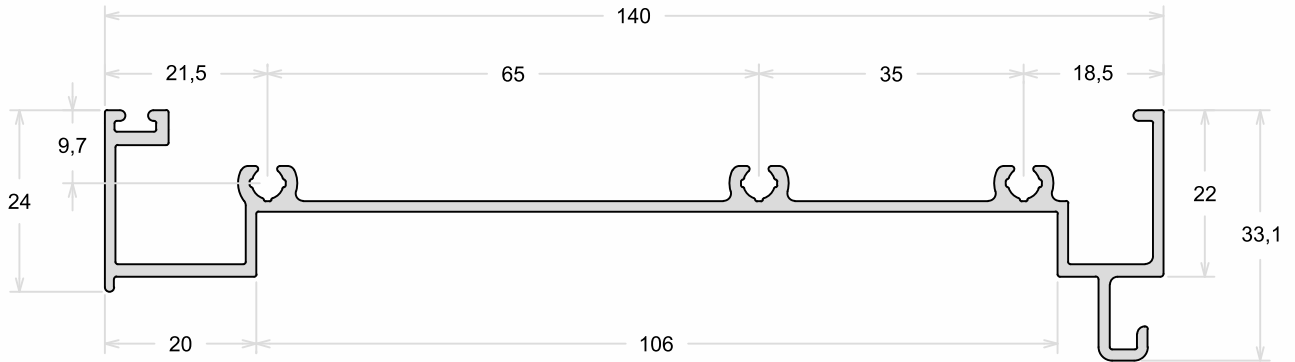

PIT-176	Travessa Intermediária
Peso (Kg/m)	Perfis De Encaixe:
1,518	

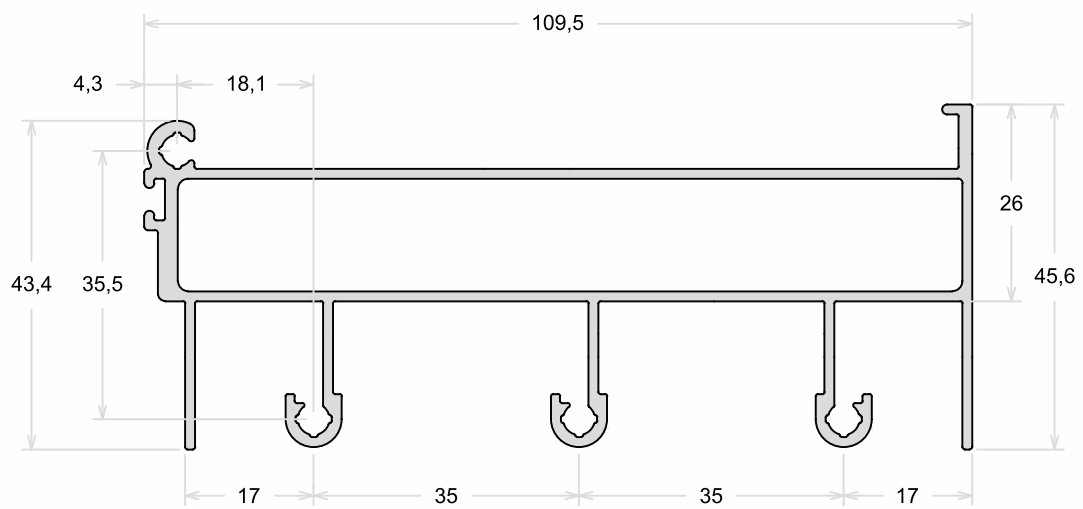

PMN-003	Marco Lateral
Peso (Kg/m)	Perfis De Encaixe:
0,991	

PLG-170	Marco Lateral
Peso (Kg/m)	Perfis De Encaixe:
0,746	

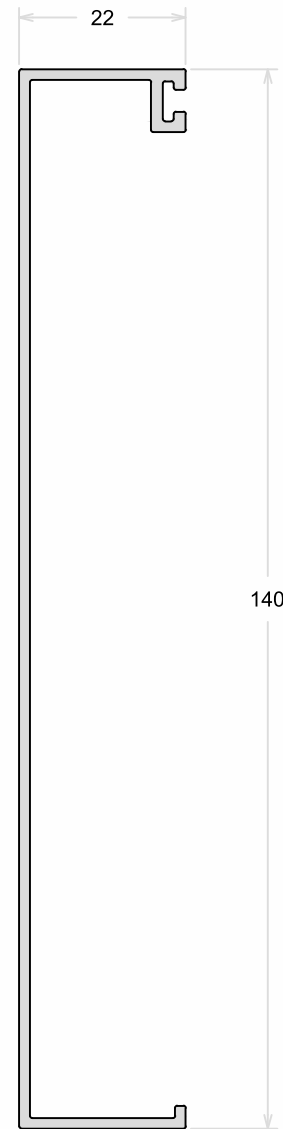
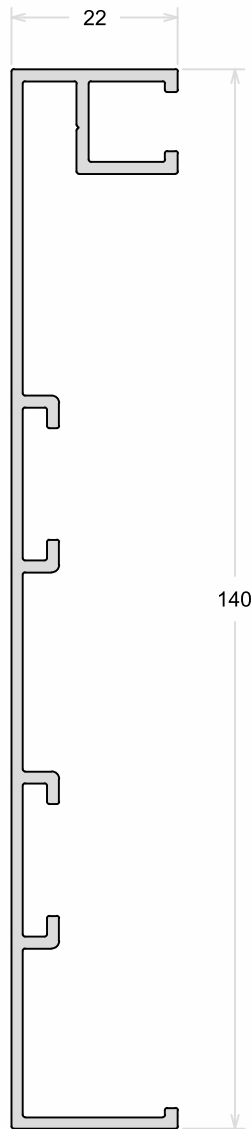

PMN-050	Marco Lateral
Peso (Kg/m)	Perfis De Encaixe:
0,651	

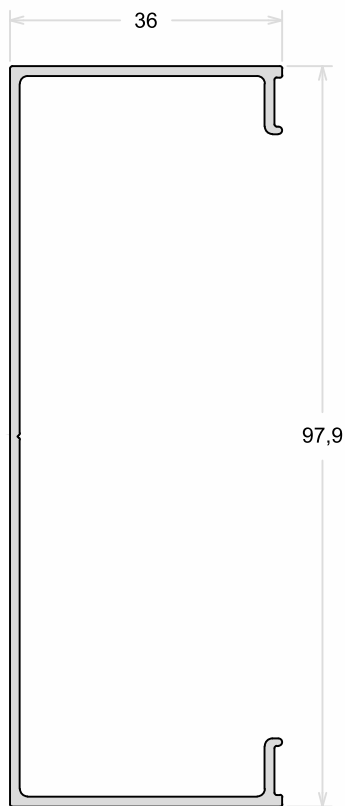

PLG-236	Marco Lateral
Peso (Kg/m)	Perfis De Encaixe:
1,185	

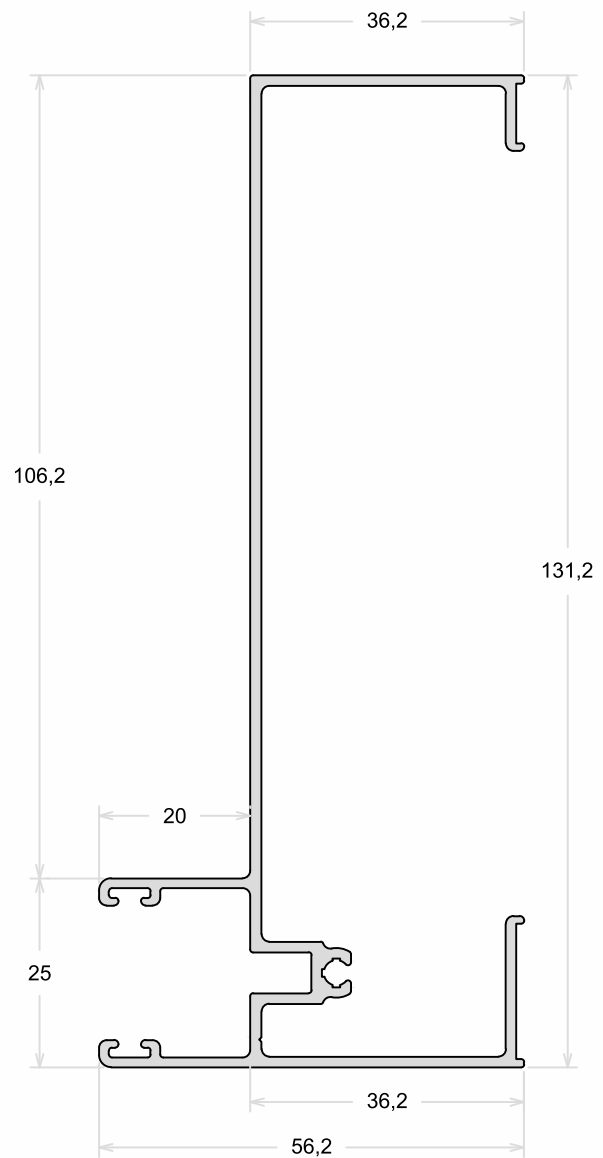

PMH-008	Tampa Externa
Peso (Kg/m)	Perfis De Encaixe:
0,771	

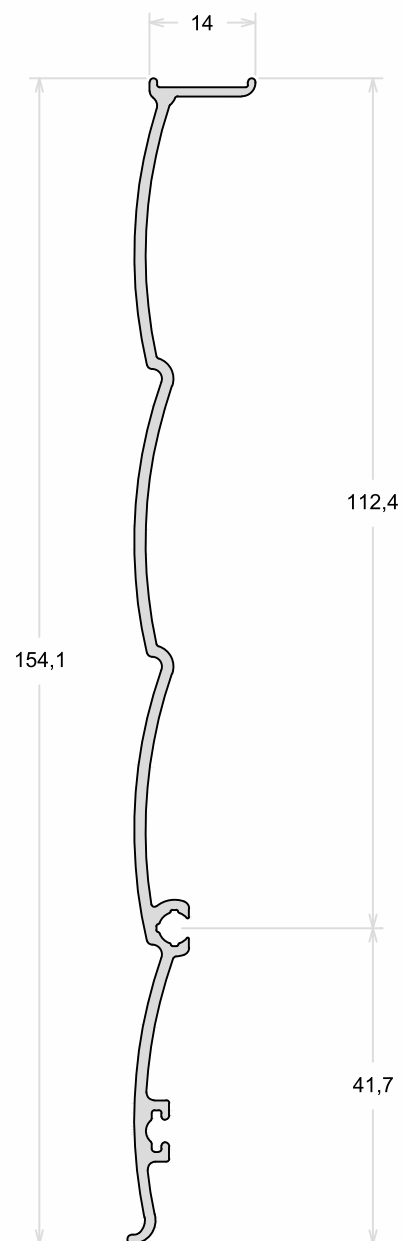

PIT-039	Tampa Externa
Peso (Kg/m)	Perfis De Encaixe:
1,168	

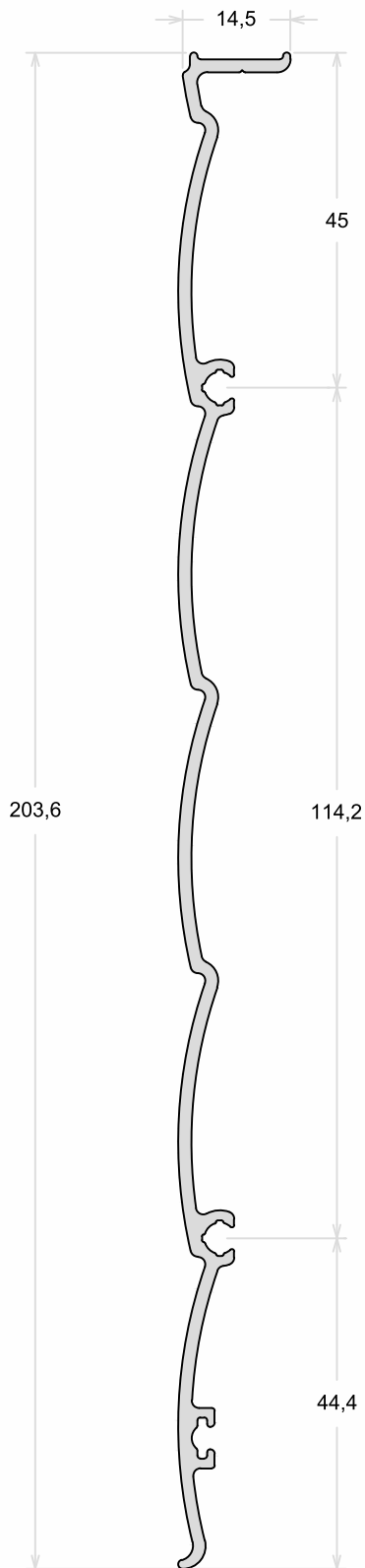

PMN-039	Tampa Externa
Peso (Kg/m)	Perfis De Encaixe:
1,248	

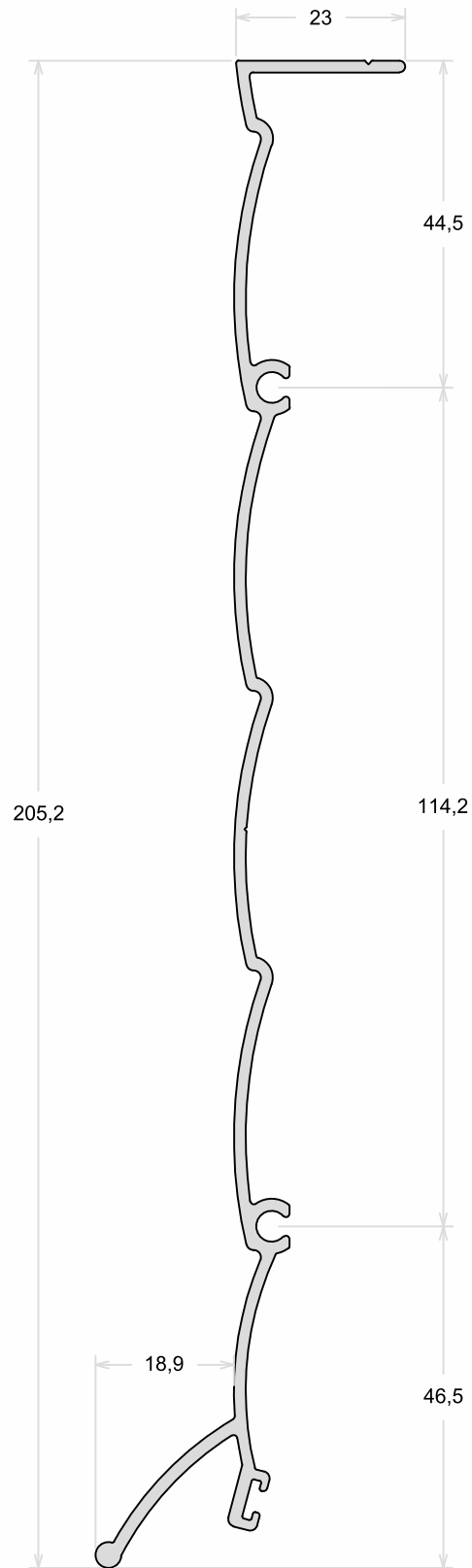

PIT-023	Tampa Interna
Peso (Kg/m)	Perfis De Encaixe:
0,878	

PIT-024	Tampa Interna
Peso (Kg/m)	Perfis De Encaixe:
1,081	

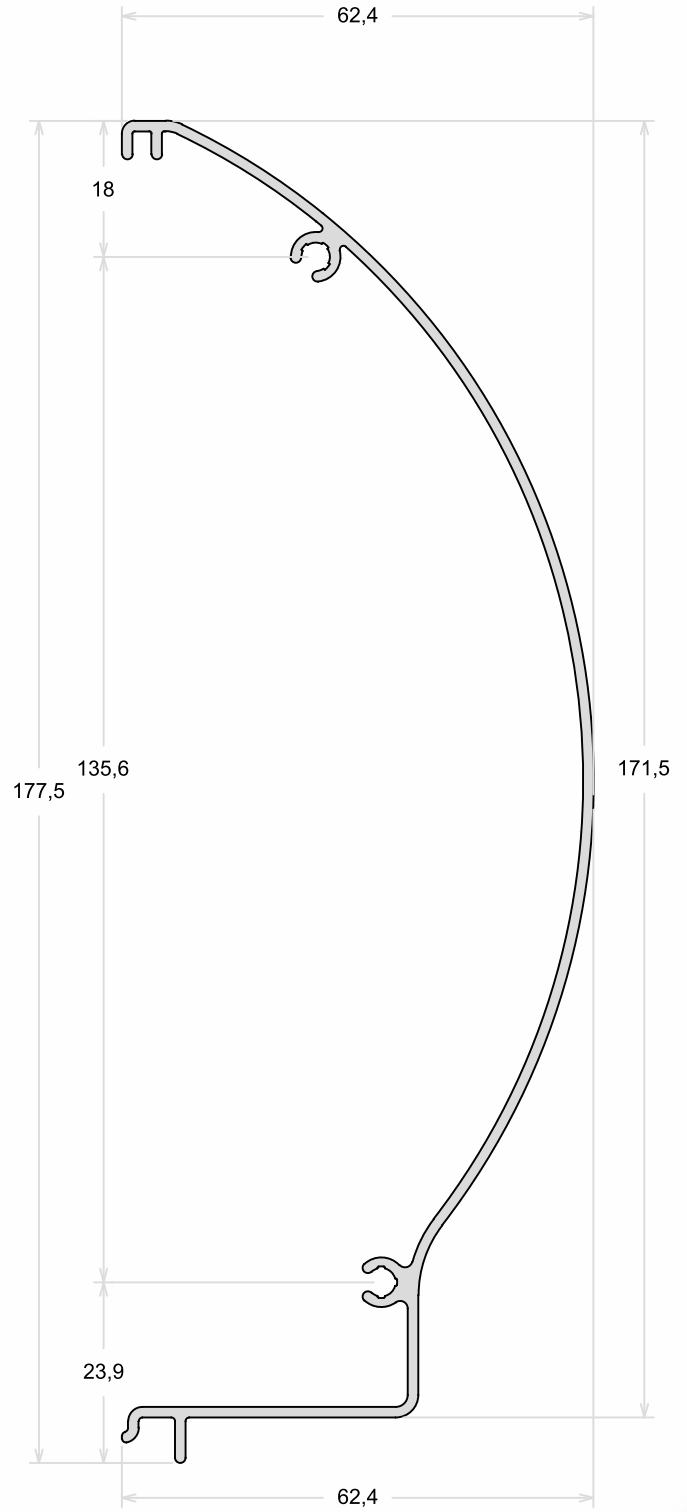
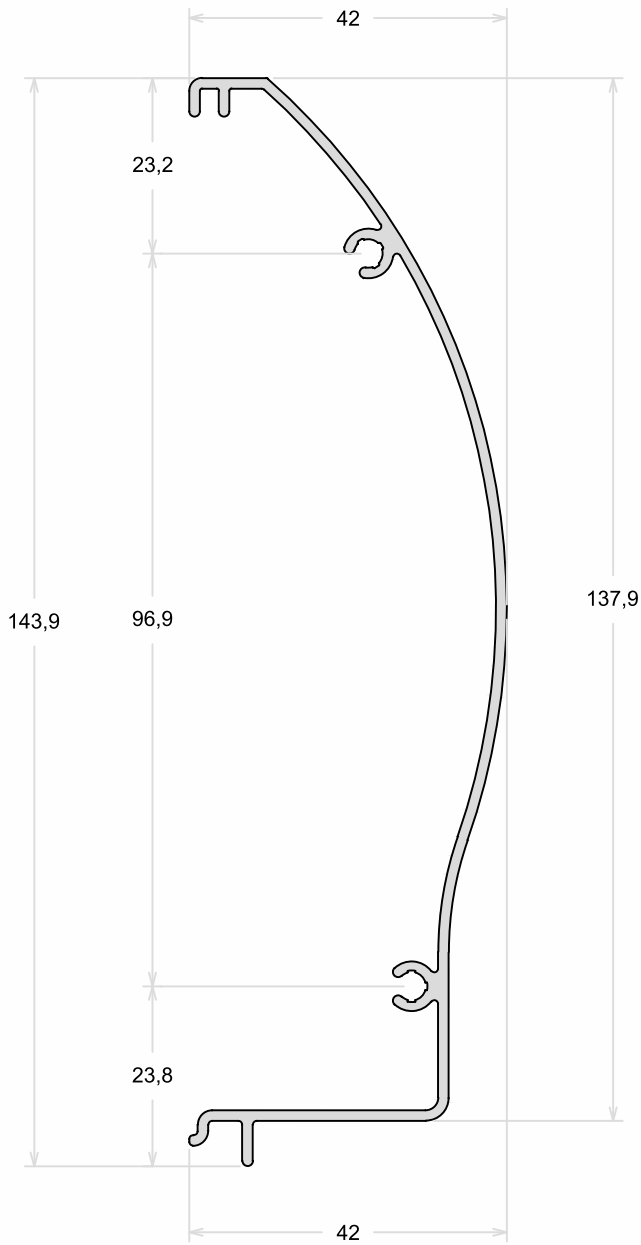

PMH-007	Tampa Interna
Peso (Kg/m)	Perfis De Encaixe:
0,897	

PMN-031	Tampa Interna
Peso (Kg/m)	Perfis De Encaixe:
1,217	

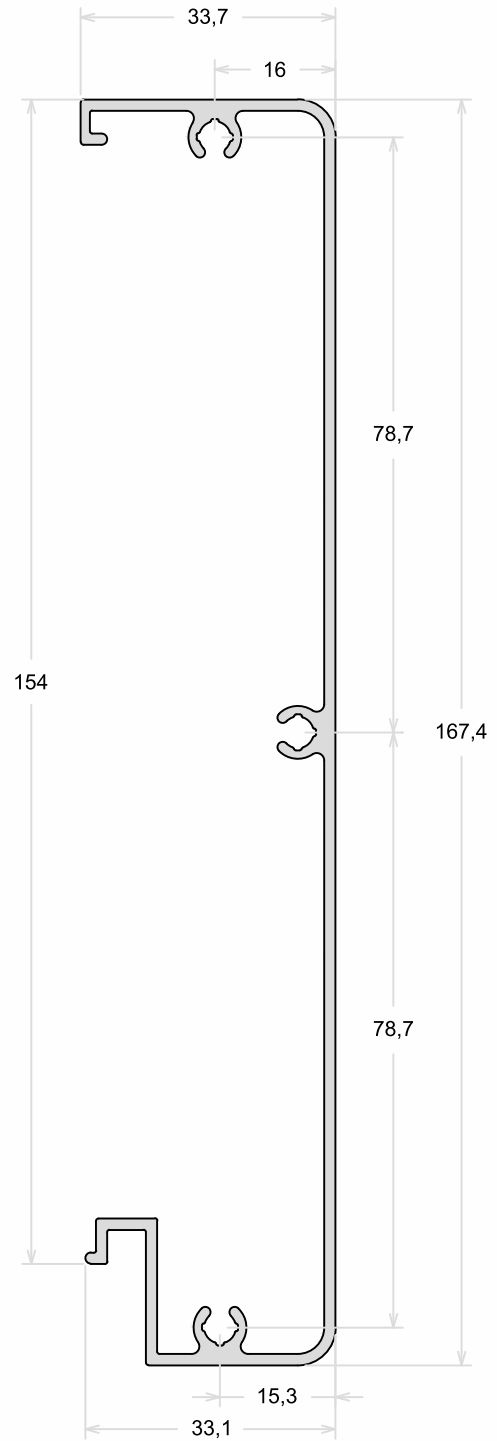
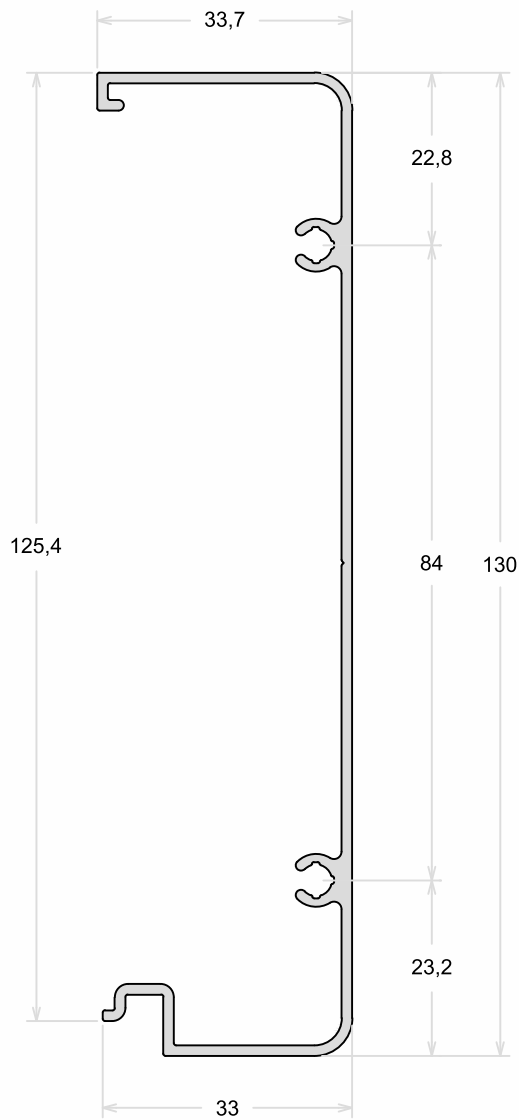

PLG-230	Tampa Interna
Peso (Kg/m)	Perfis De Encaixe:
1,573	

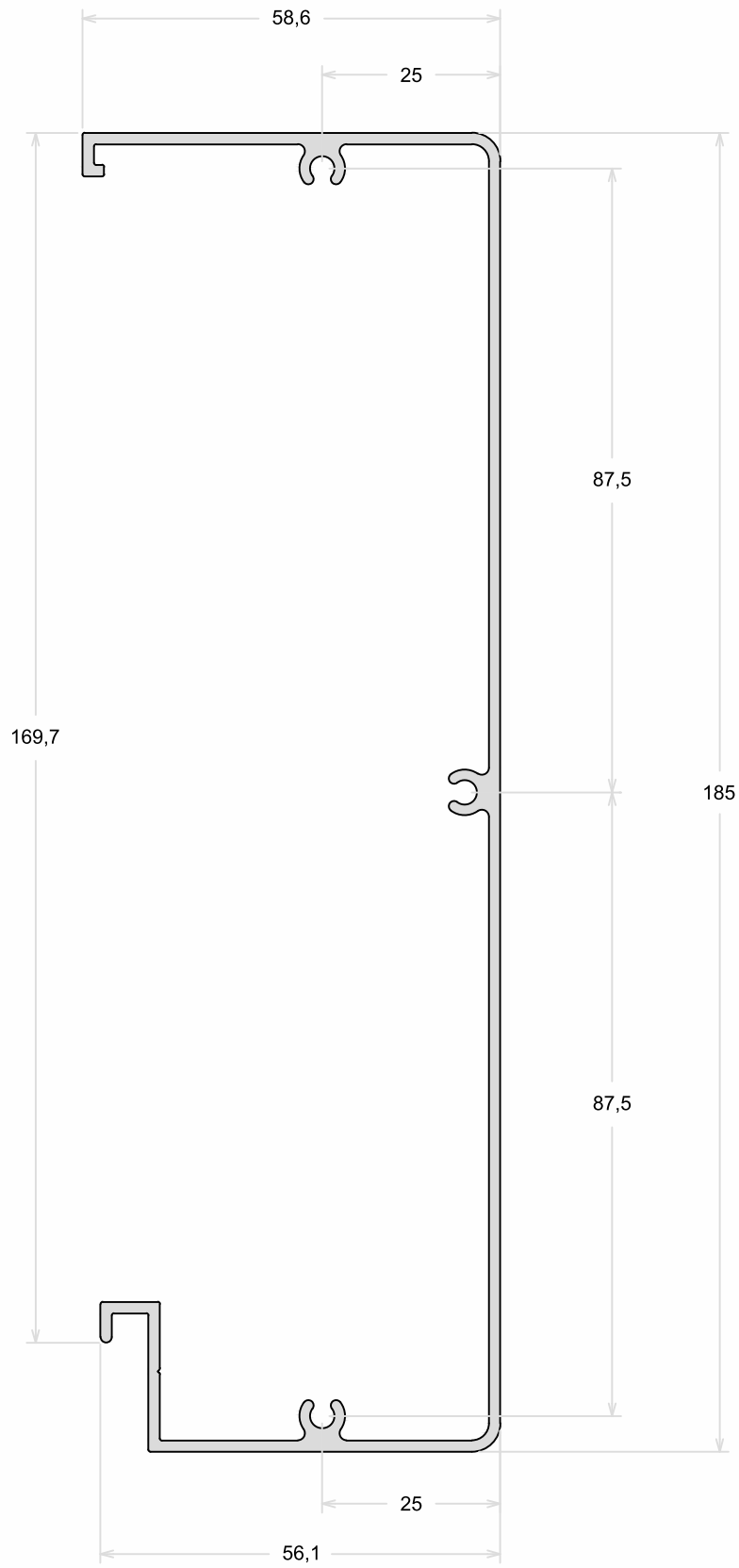

PIT-114	Marco Superior
Peso (Kg/m)	Perfis De Encaixe:
0,656	

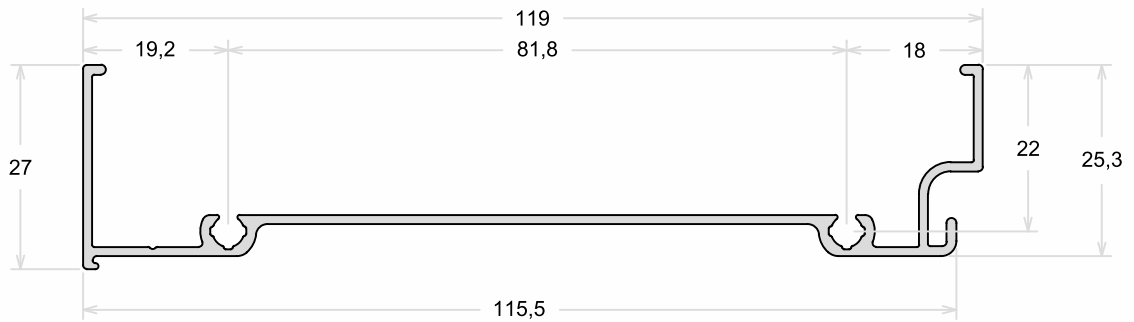

PIT-025	Travessa Intermediária
Peso (Kg/m)	Perfis De Encaixe:
1,181	

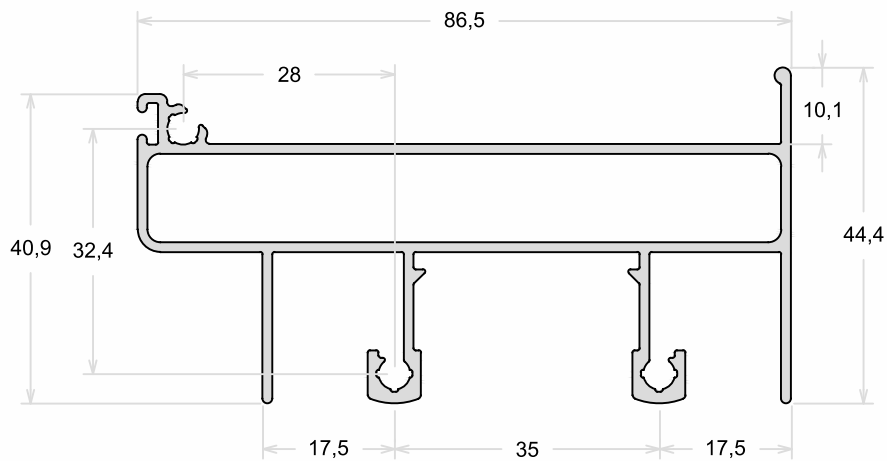

PIT-026	Travessa Intermediária
Peso (Kg/m)	Perfis De Encaixe:
0,794	

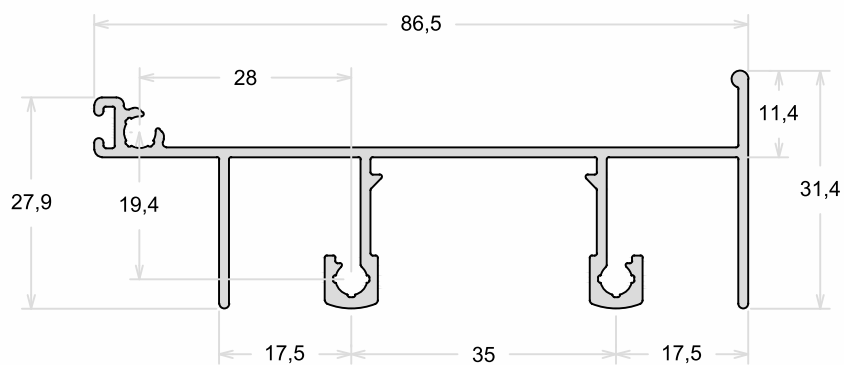

PIT-112	Marco Inferior
Peso (Kg/m)	Perfis De Encaixe:
0,996	

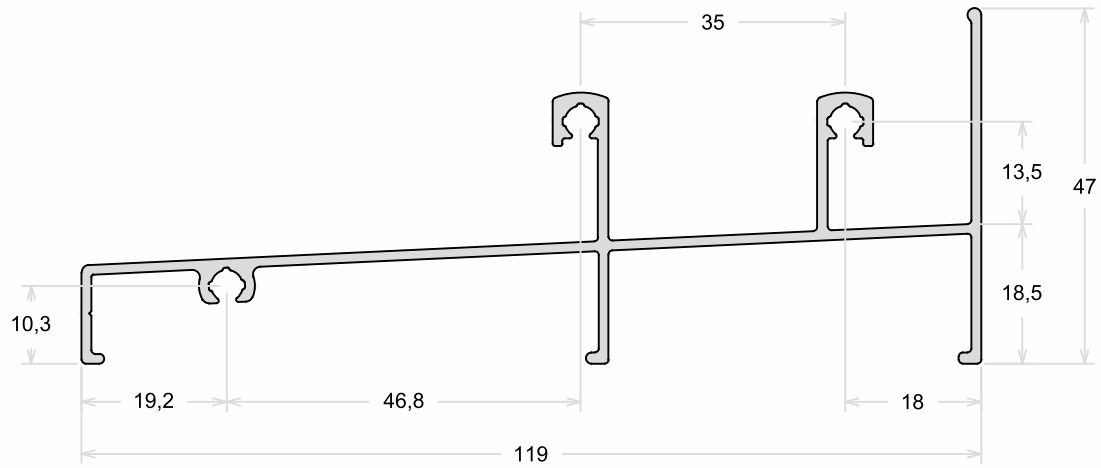

PIT-111	Marco Inferior
Peso (Kg/m)	Perfis De Encaixe:
1,041	

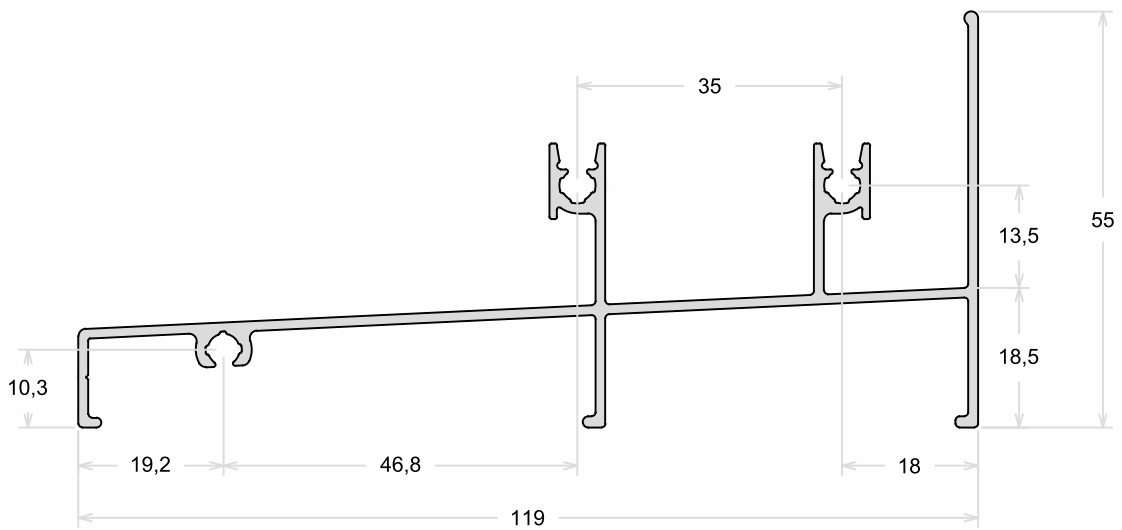

PIT-113	Marco Lateral
Peso (Kg/m)	Perfis De Encaixe:
0,555	

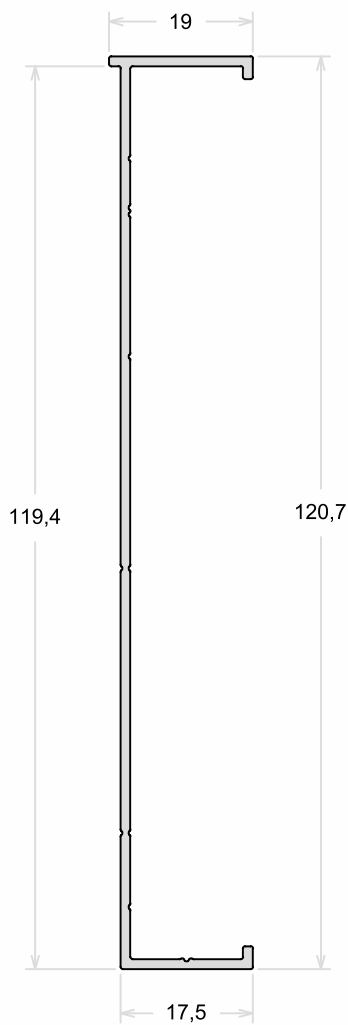

PIT-115	Marco Lateral
Peso (Kg/m)	Perfis De Encaixe:
1,058	

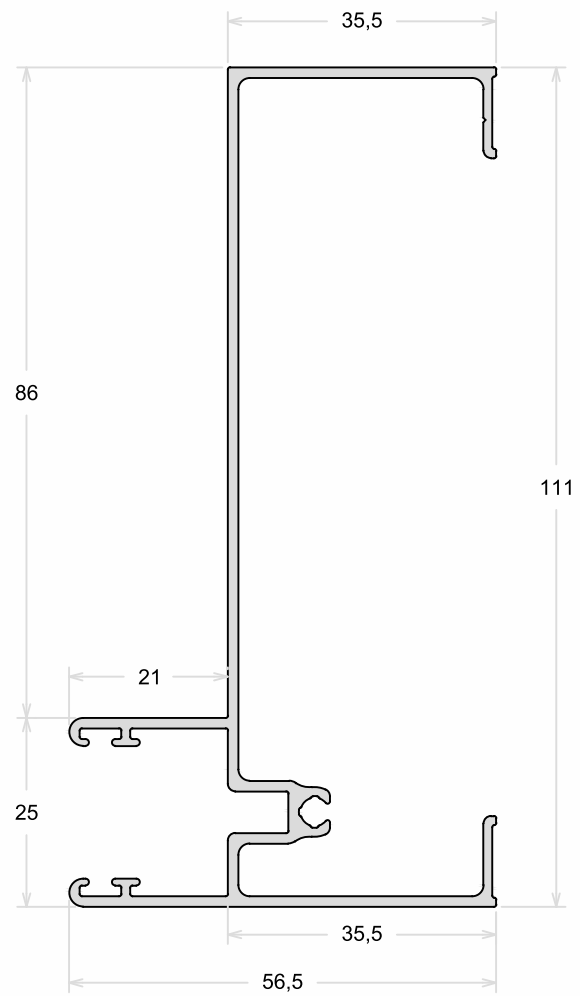

PIT-119	Marco Superior
Peso (Kg/m)	Perfis De Encaixe:
0,858	

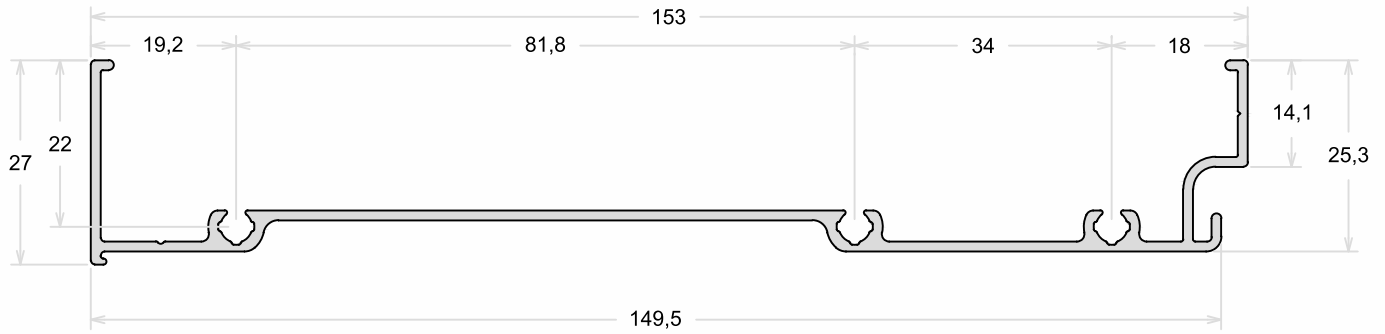

PIT-118	Travessa Intermediária
Peso (Kg/m)	Perfis De Encaixe:
1,061	

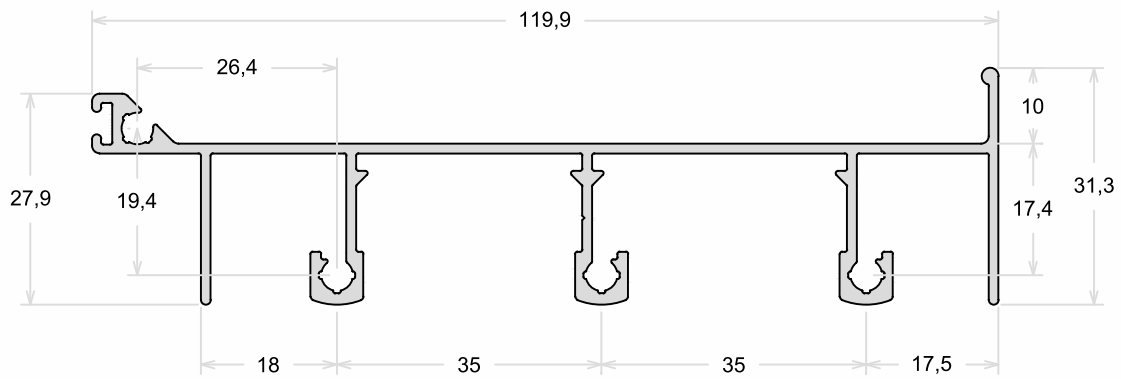

PIT-124	Travessa Intermediária
Peso (Kg/m)	Perfis De Encaixe:
1,607	

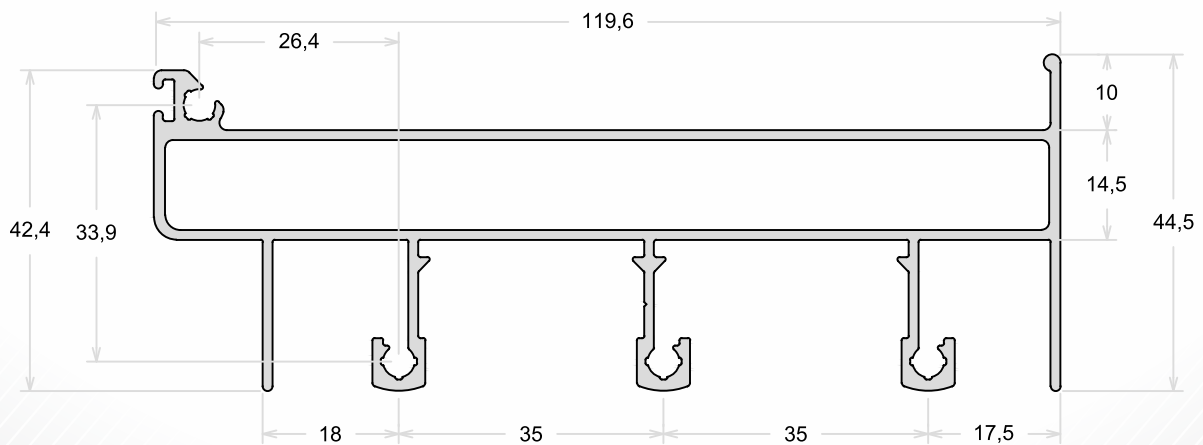

PIT-120	Marco Inferior
Peso (Kg/m)	Perfis De Encaixe:
1,245	

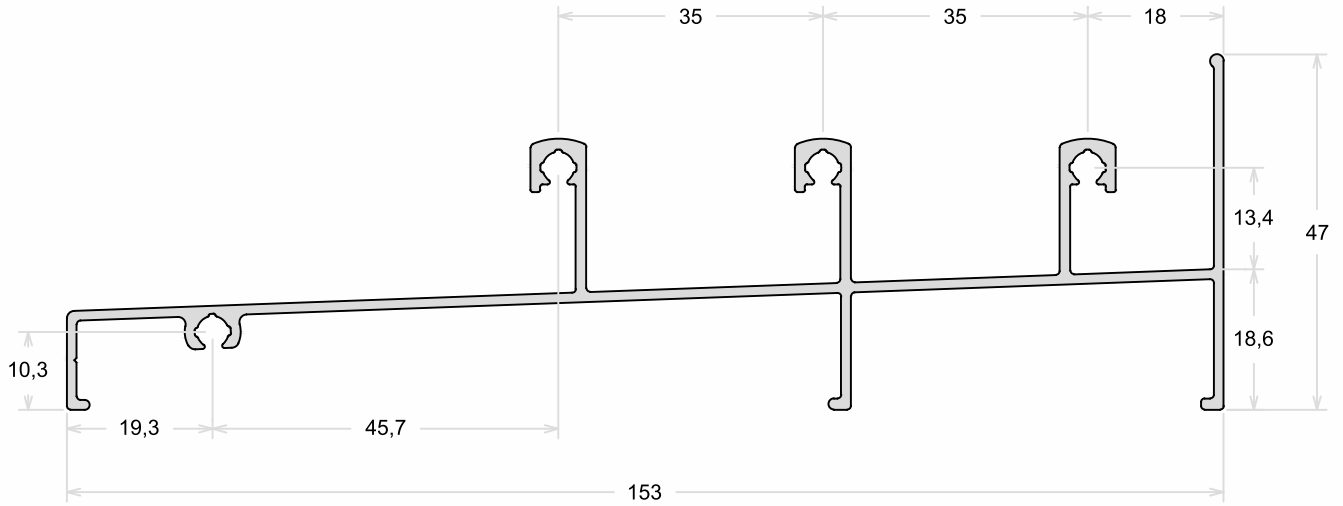

PIT-121	Marco Inferior
Peso (Kg/m)	Perfis De Encaixe:
1,294	

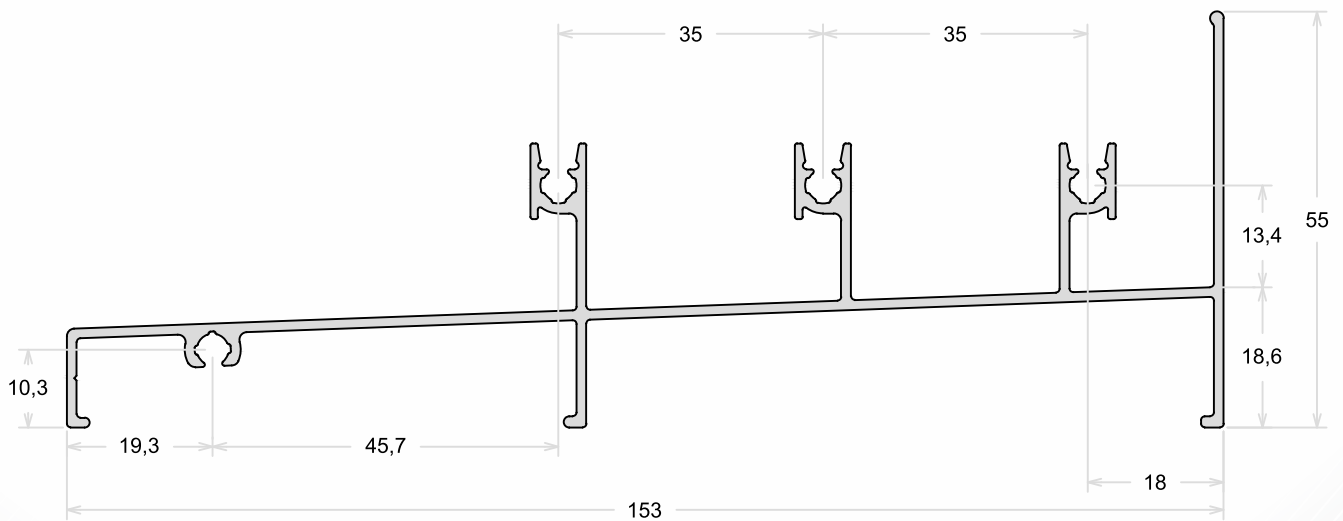

PIT-122	Marco Lateral
Peso (Kg/m)	Perfis De Encaixe:
0,774	

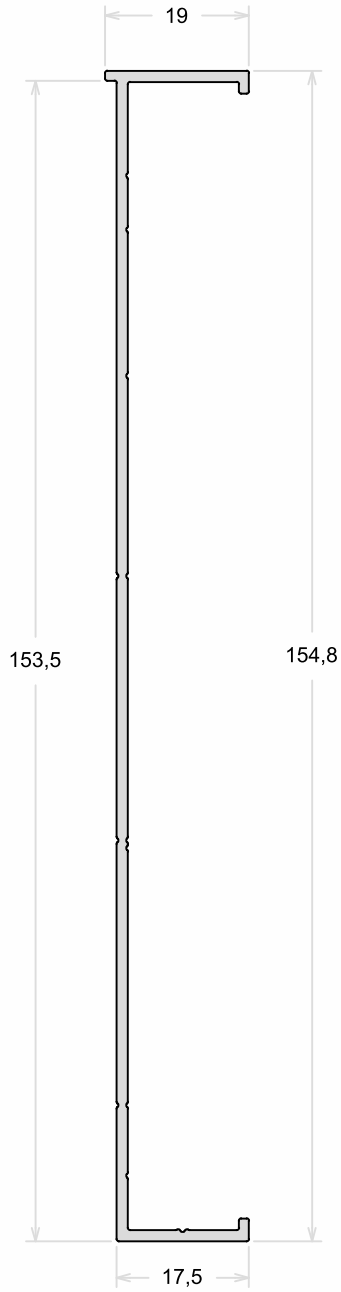

PIT-123	Marco Lateral
Peso (Kg/m)	Perfis De Encaixe:
1,185	

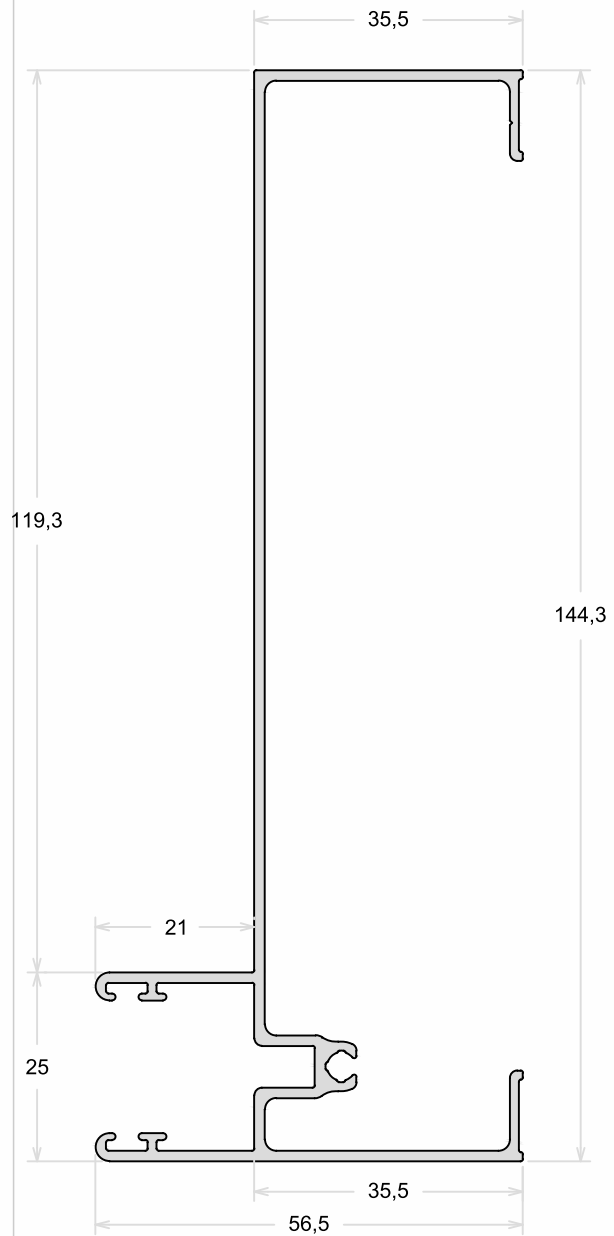

PIT-126	Travessa Intermediária
Peso (Kg/m)	Perfis De Encaixe:
0,805	

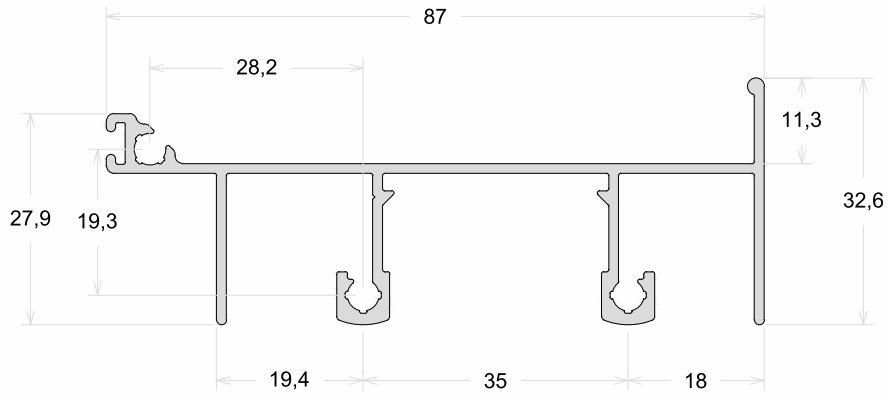

PSU-125	Travessa Intermediária
Peso (Kg/m)	Perfis De Encaixe:
1,116	

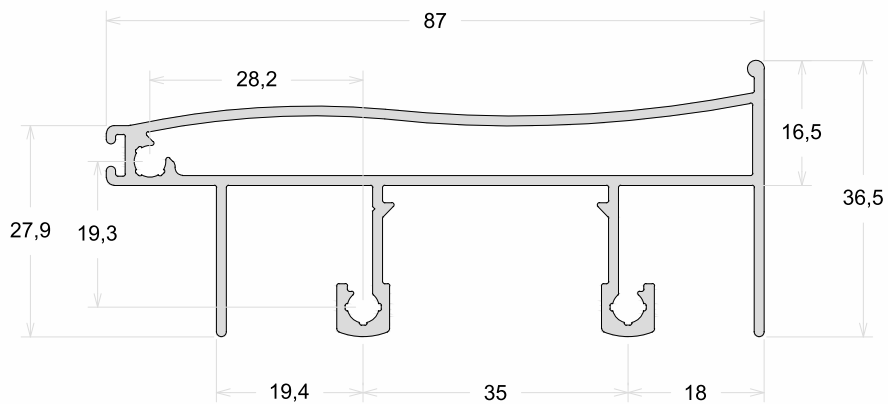

PIT-127	Tampa Externa
Peso (Kg/m)	Perfis De Encaixe:
0,749	

PSU-128	Tampa Externa
Peso (Kg/m)	Perfis De Encaixe:
0,935	

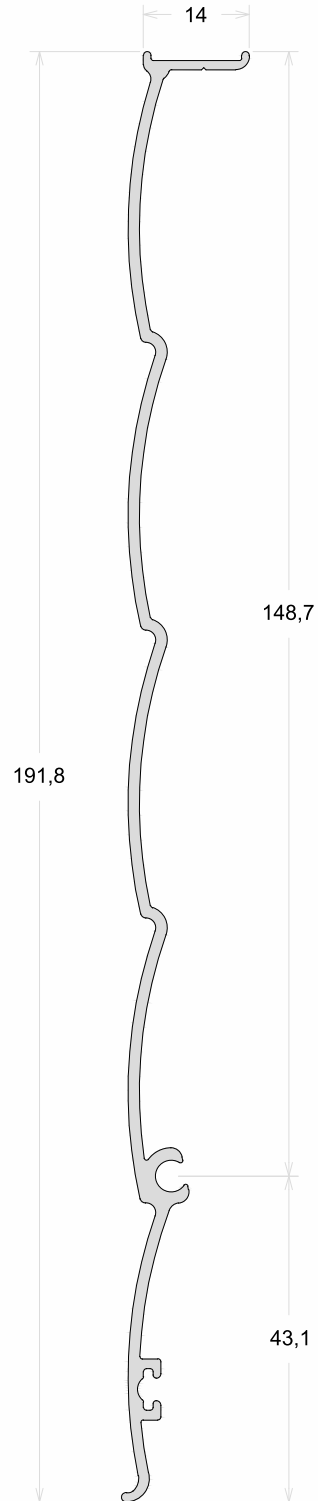
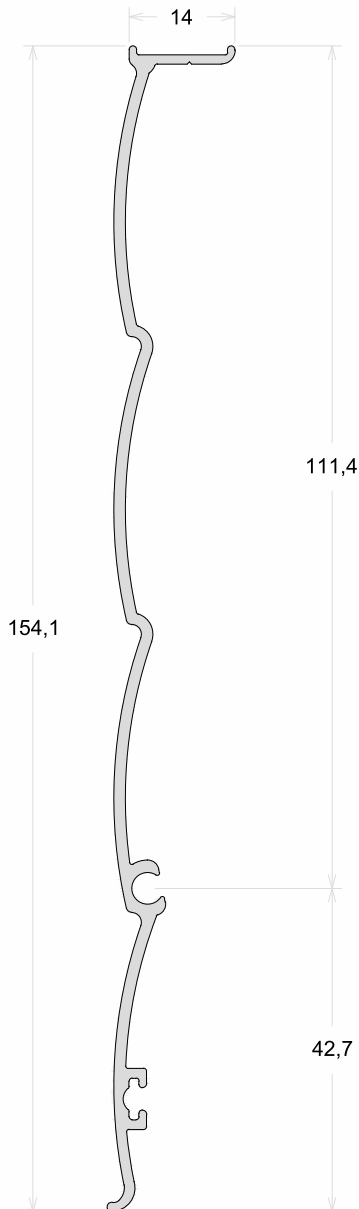

PIT-116	Guia Da Persiana
Peso (Kg/m)	Perfis De Encaixe:
0,697	

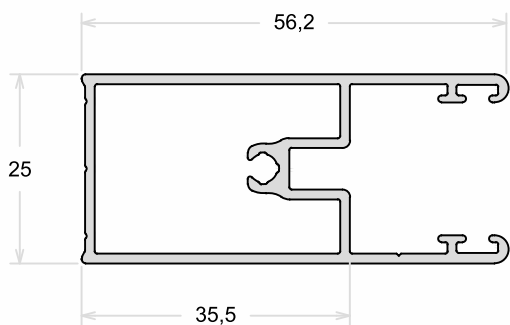

PMN-007	Guia Da Persiana
Peso (Kg/m)	Perfis De Encaixe:
0,660	

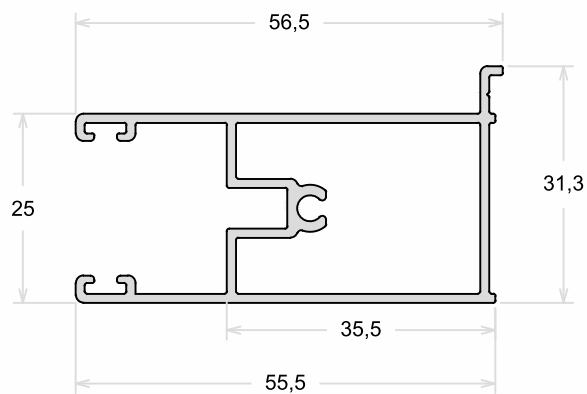

PIT-117	Guia Duplo Da Persiana
Peso (Kg/m)	Perfis De Encaixe:
1,006	

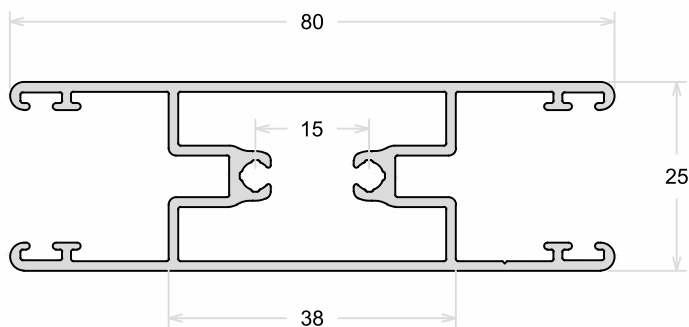

PIT-011	Tubo Reolhedor - 40mm
Peso (Kg/m)	Perfis De Encaixe:
0,475	

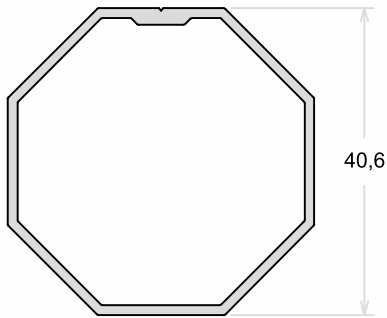

PIT-008	Tubo Reolhedor - 60mm
Peso (Kg/m)	Perfis De Encaixe:
0,884	

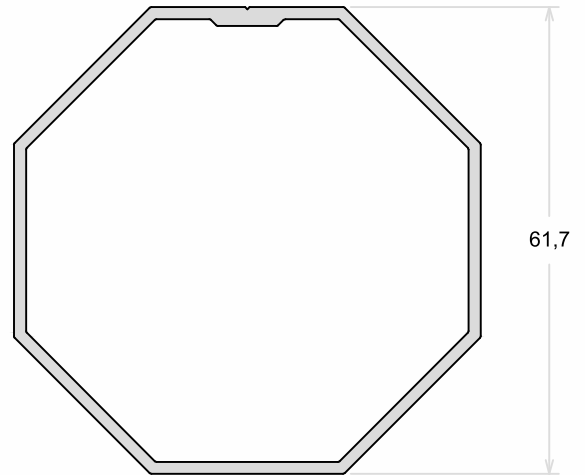

PIT-009	Terminal Da Persiana
Peso (Kg/m)	Perfis De Encaixe:
0,410	

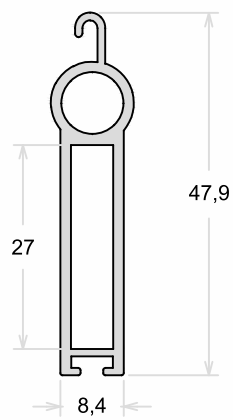

PSU-2586	Click Do Marco Inferior
Peso (Kg/m)	Perfis De Encaixe:
0,063	

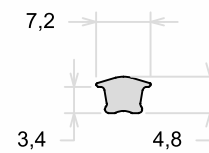

PSU-079	PSU-079S	Marco Maxim Ar
Peso (Kg/m)	Peso (Kg/m)	Perfis De Encaixe:
0,297	0,330	

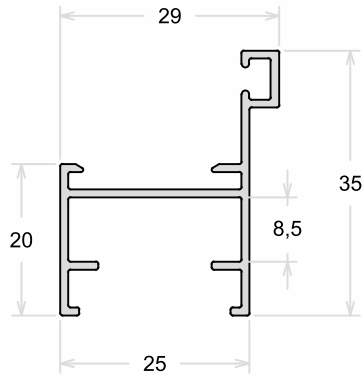

CX-672	Marco Maxim Ar
Peso (Kg/m)	Perfis De Encaixe:
0,455	

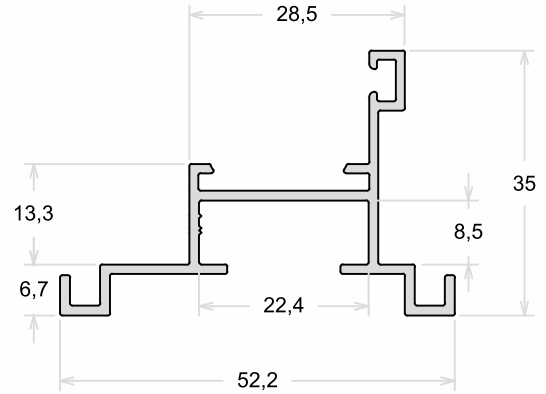

PSU-086	PSU-086S	Coluna - Maxim Ar
Peso (Kg/m)	Peso (Kg/m)	Perfis De Encaixe:
0,571	0,595	

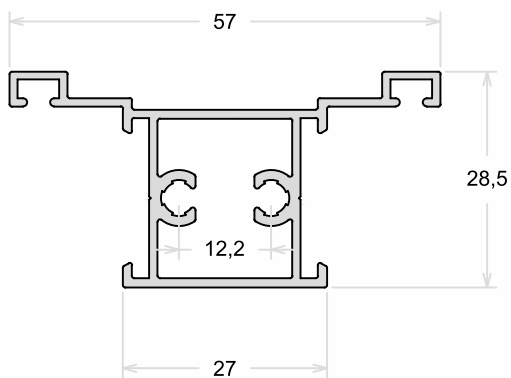

PSU-085	PSU-085S	Travessa Maxim Ar
Peso (Kg/m)	Peso (Kg/m)	Perfis De Encaixe:
0,448	0,502	

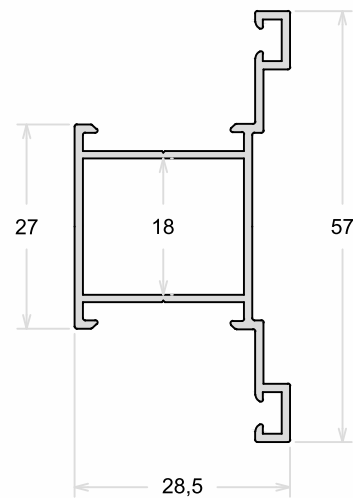

PSU-292	Inversor De Baguetes
Peso (Kg/m)	Perfis De Encaixe:
0,214	

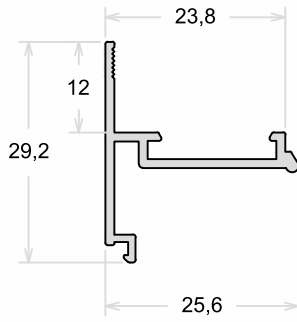

PSU-083	Pingadeira Maxim Ar
Peso (Kg/m)	Perfis De Encaixe:
0,145	

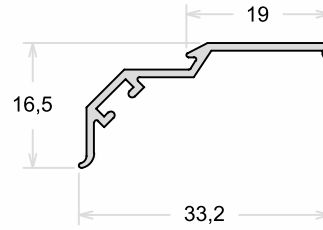

PSU-082	Folha Horizontal - Maxim Ar
Peso (Kg/m)	Perfis De Encaixe:
0,327	

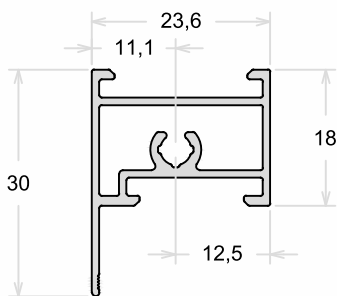

PSU-080	PSU-080S	Folha Superior
Peso (Kg/m)	Peso (Kg/m)	Perfis De Encaixe:
0,317	0,343	

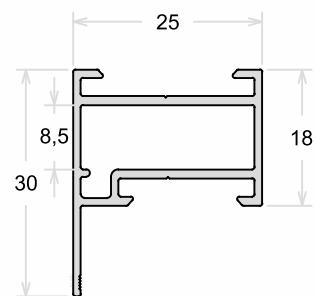

PSU-081	Folha Maxim Ar
Peso (Kg/m)	Perfis De Encaixe:
0,361	

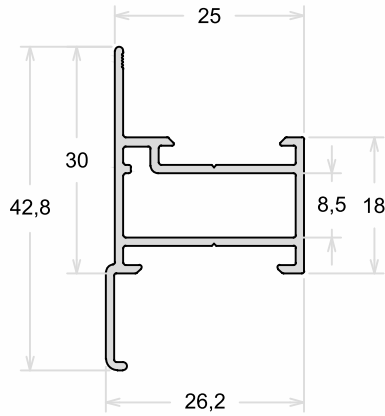

PSU-200	PSU-200S	Folha Maxim Ar
Peso (Kg/m)	Peso (Kg/m)	Perfis De Encaixe:
0,389	0,443	

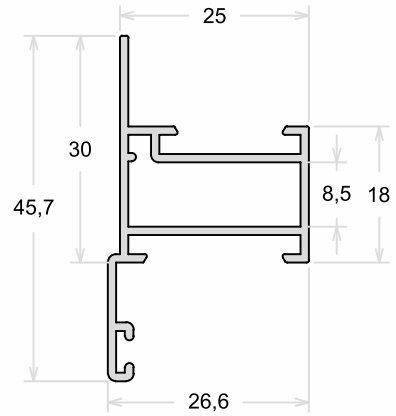

PSU-091	Folha Superior Maxim Ar Sem Bague
Peso (Kg/m)	Perfis De Encaixe:
0,340	

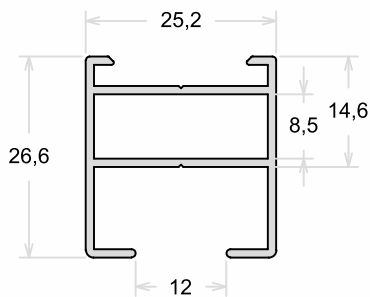

PSU-090	Folha Maxim Ar Sem Bague
Peso (Kg/m)	Perfis De Encaixe:
0,384	

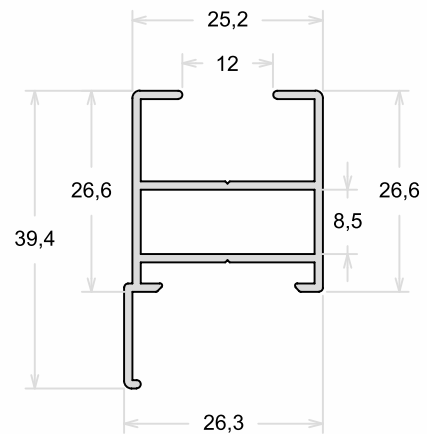

PSU-093	Marco Basculante
Peso (Kg/m)	Perfis De Encaixe:
0,267	

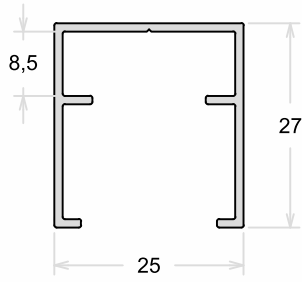

PSU-094	Montante Basculante
Peso (Kg/m)	Perfis De Encaixe:
0,375	

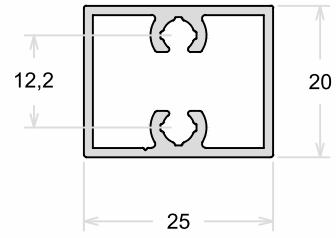

PSU-095	Montante Basculante
Peso (Kg/m)	Perfis De Encaixe:
0,228	

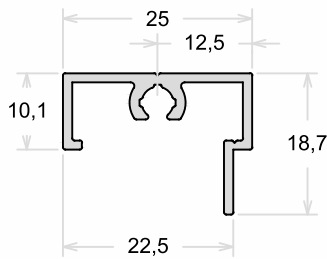

PSU-099	Complemento Basculante
Peso (Kg/m)	Perfis De Encaixe:
0,226	

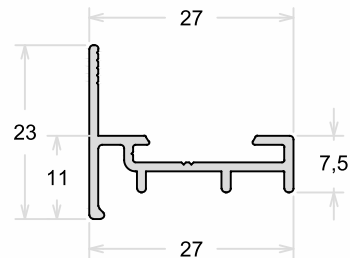

PSU-097

Folha Horizontal Basculante

Peso
(Kg/m)
0,397

Perfis De Encaixe:

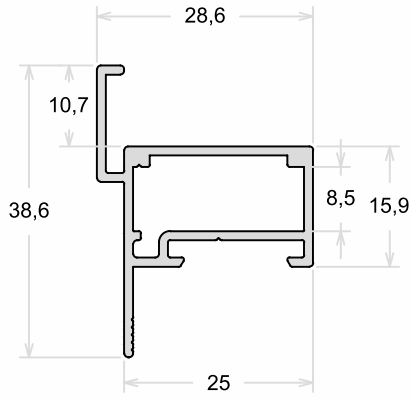

PSU-098

Folha Horizontal Basculante

Peso
(Kg/m)
0,397

Perfis De Encaixe:

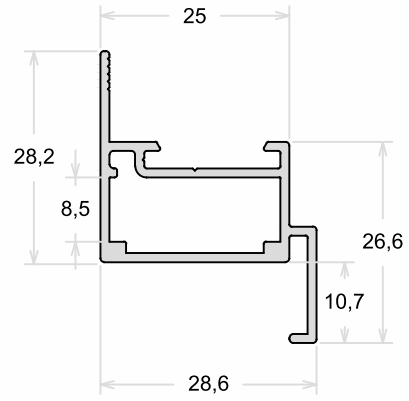

PSU-096

Folha Vertical Basculante

Peso
(Kg/m)
0,312

Perfis De Encaixe:

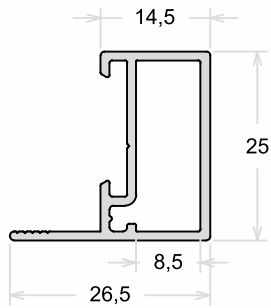

PSU-100

Complemento Basculante

Peso
(Kg/m)
0,154

Perfis De Encaixe:

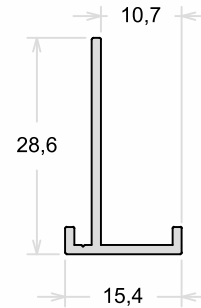

PSU-074	Folha Vertical Camarão
Peso (Kg/m)	Perfis De Encaixe:
0,500	

PSU-072	Folha Vertical Camarão
Peso (Kg/m)	Perfis De Encaixe:
0,437	

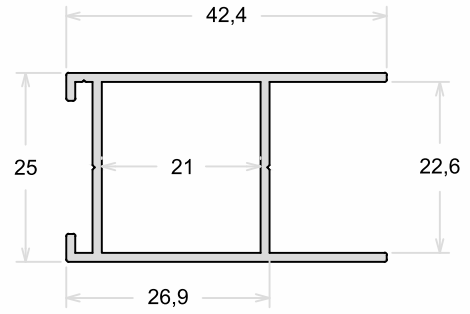
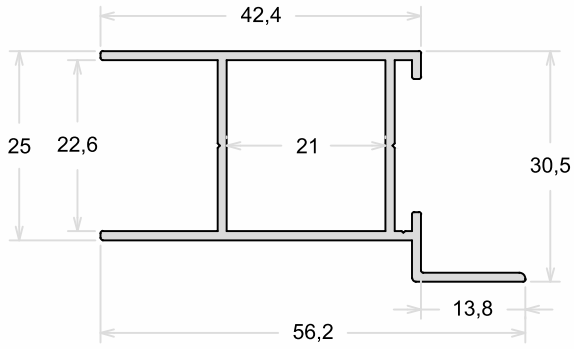

PSU-073	Folha Horizontal Camarão
Peso (Kg/m)	Perfis De Encaixe:
0,447	

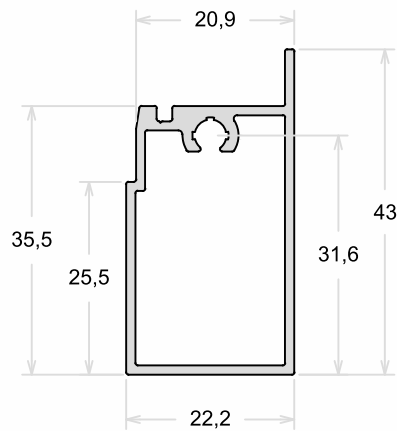

PSU-102 Baguete Horizontal e Vertical

Peso (Kg/m): 0,105

Perfis De Encaixe:

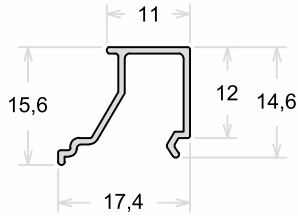

PSU-104 Baguete Vertical

Peso (Kg/m): 0,109

Perfis De Encaixe:

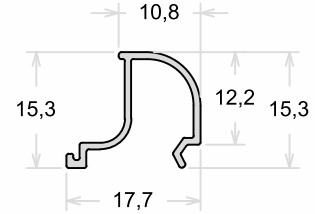

PSU-115 Baguete Horizontal e Vertical

Peso (Kg/m): 0,108

Perfis De Encaixe:

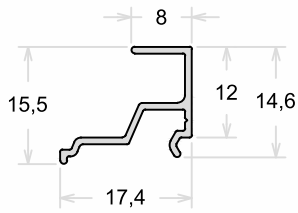

PSU-116 Baguete Vertical

Peso (Kg/m): 0,103

Perfis De Encaixe:

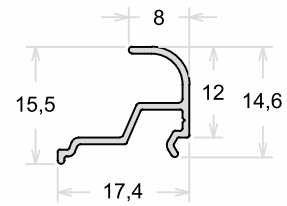

PSU-203 Baguete Terminal Veneziana

Peso (Kg/m): 0,135

Perfis De Encaixe:

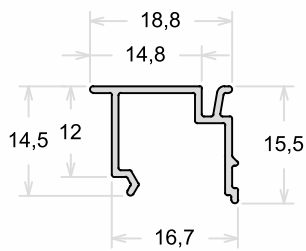

PSU-108 Complemento Veneziana

Peso (Kg/m): 0,140

Perfis De Encaixe:

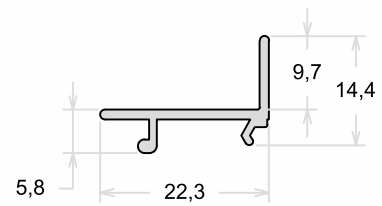

PSU-103

Baguete Do Marco Maxim Ar

Peso
(Kg/m)

0,140

Perfis De Encaixe:

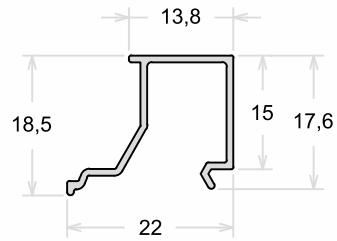

CL-050

Complemento Tela Mosquiteira

Peso
(Kg/m)

0,133

Perfis De Encaixe:

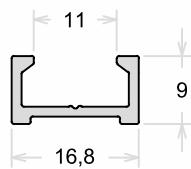

DS-036

Complemento Tela Mosquiteira

Peso
(Kg/m)

0,152

Perfis De Encaixe:

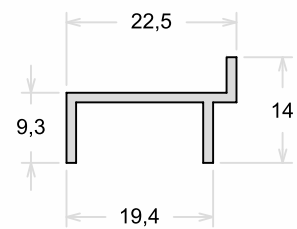

CM-174	Contramarco
Peso (Kg/m)	Perfis De Encaixe:
0,369	

CM-173	Contramarco
Peso (Kg/m)	Perfis De Encaixe:
0,462	

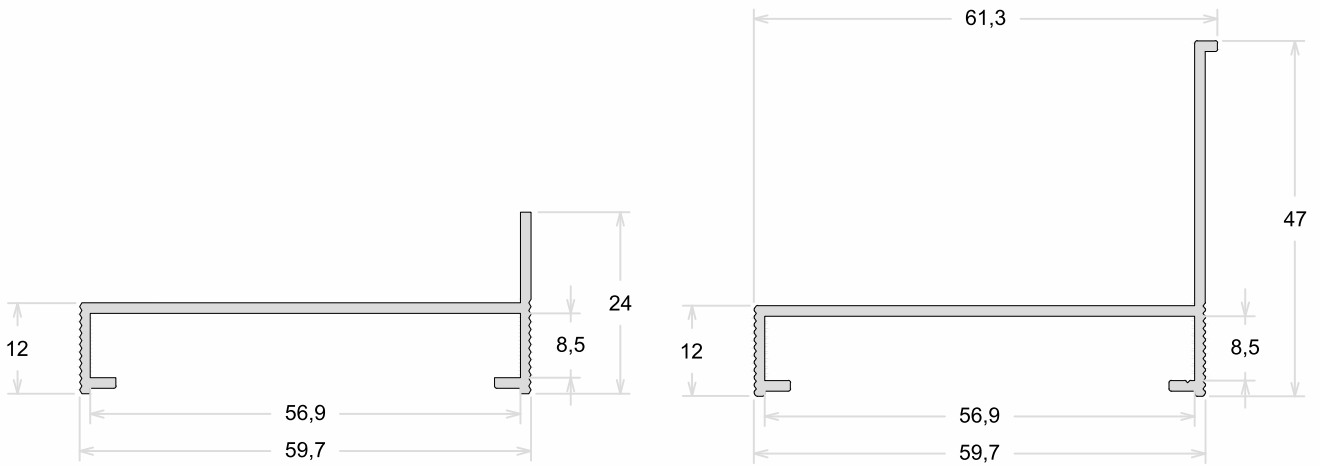

CM-175	Chumbador Contramarco
Peso (Kg/m)	Perfis De Encaixe:
0,610	

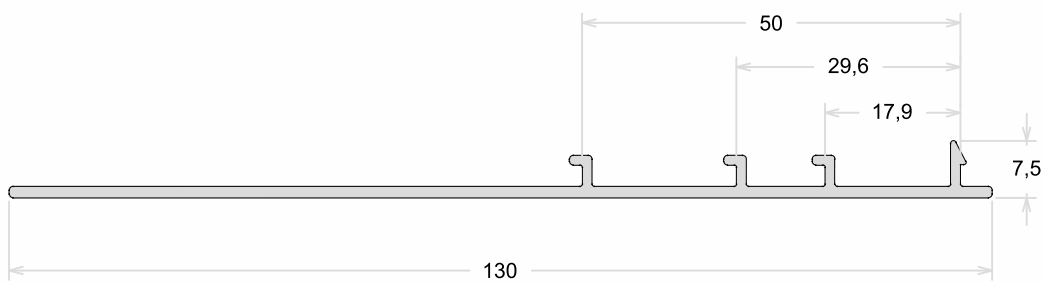

MP-348	Arremate
Peso (Kg/m)	Perfis De Encaixe:
0,174	

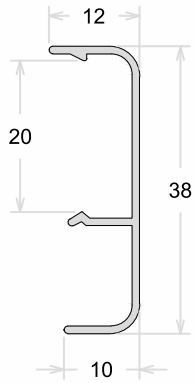

MP-3348	Arremate
Peso (Kg/m)	Perfis De Encaixe:
0,206	

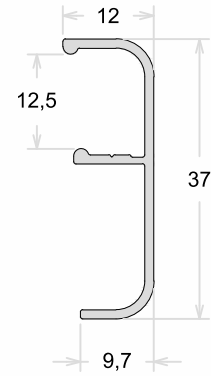

MP-347	MP-347S	Arremate
Peso (Kg/m)	Peso (Kg/m)	Perfis De Encaixe:
0,169	0,217	

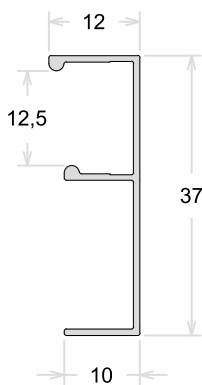

MN-014	Arremate
Peso (Kg/m)	Perfis De Encaixe:
0,197	

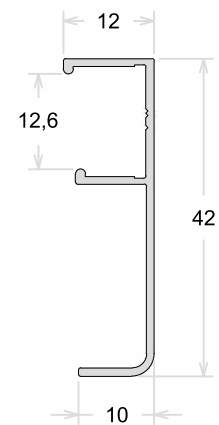

ME-092	Arremate Centro De Vão
Peso (Kg/m)	Perfis De Encaixe:
0,160	

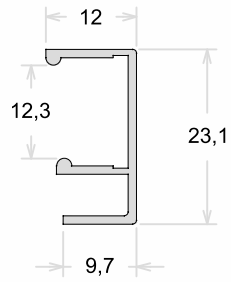

MP-346	Arremate
Peso (Kg/m)	Perfis De Encaixe:
0,302	

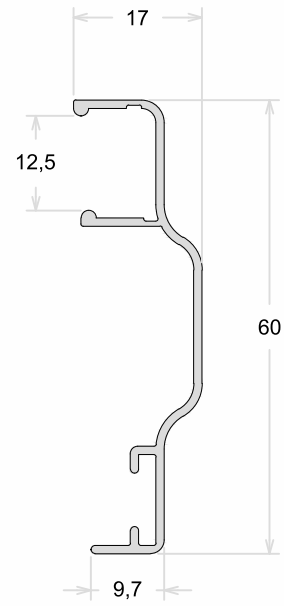

MP-349	Arremate
Peso (Kg/m)	Perfis De Encaixe:
0,298	

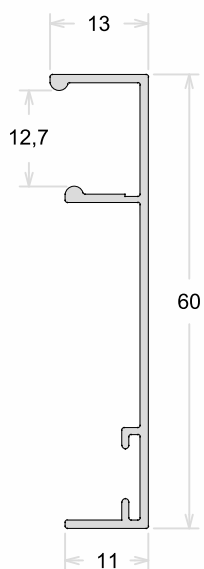

MP-350	Arremate
Peso (Kg/m)	Perfis De Encaixe:
0,268	

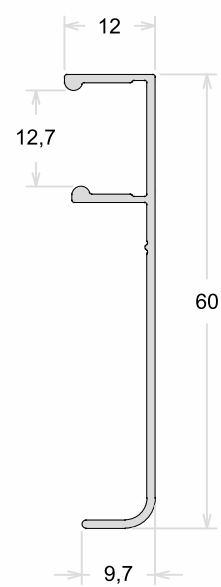

PEX-002	Arremate / Rodapé
Peso (Kg/m)	Perfis De Encaixe:
0,332	

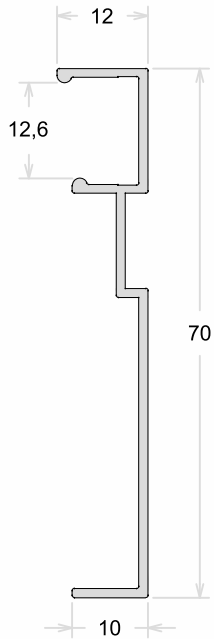

PEX-001	Arremate / Rodapé
Peso (Kg/m)	Perfis De Encaixe:
0,430	

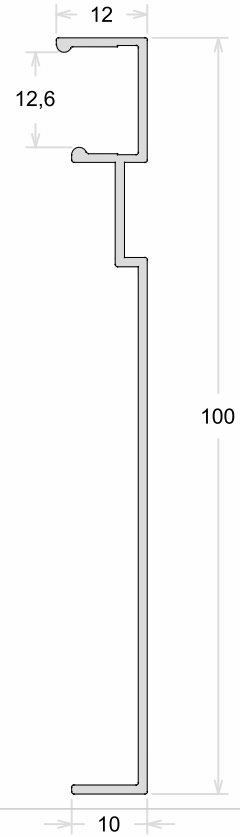

CX-905	Arremate De Piso
Peso (Kg/m)	Perfis De Encaixe:
0,186	

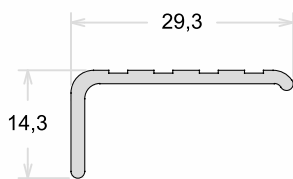

ME-013	Arremate De Piso
Peso (Kg/m)	Perfis De Encaixe:
0,252	

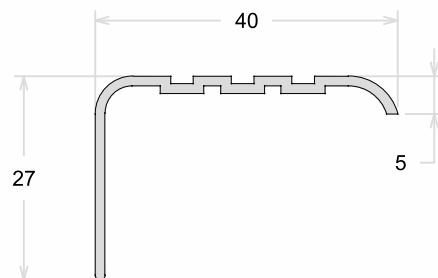

PLG-044	Marco Superior
Peso (Kg/m)	Perfis De Encaixe:
1,065	

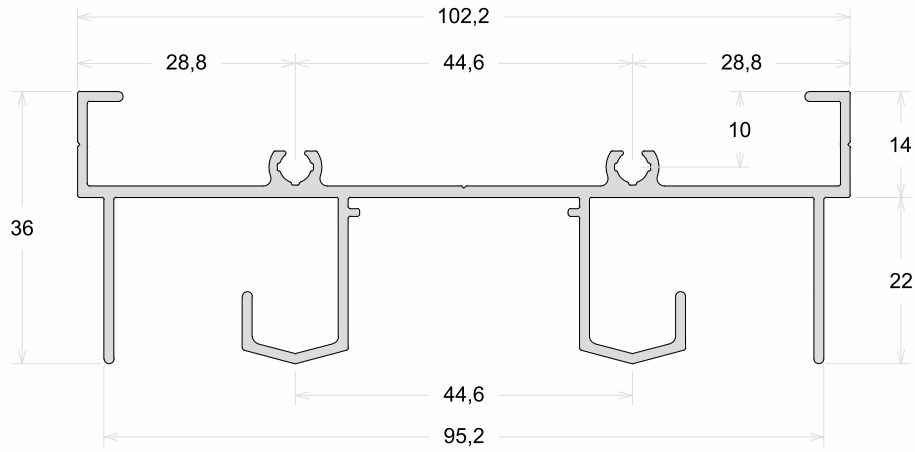

PLG-024	Marco Inferior
Peso (Kg/m)	Perfis De Encaixe:
1,031	

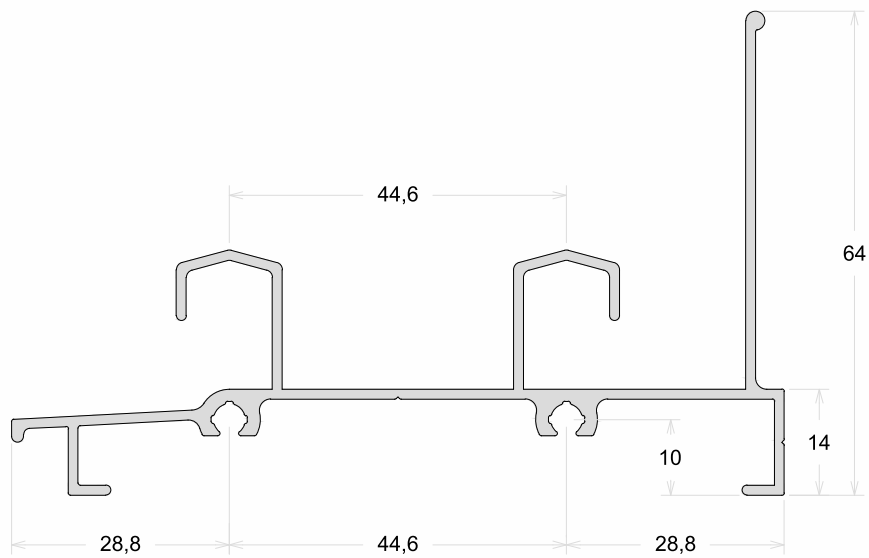

PLG-047	Marco Inferior
Peso (Kg/m)	Perfis De Encaixe:
0,967	

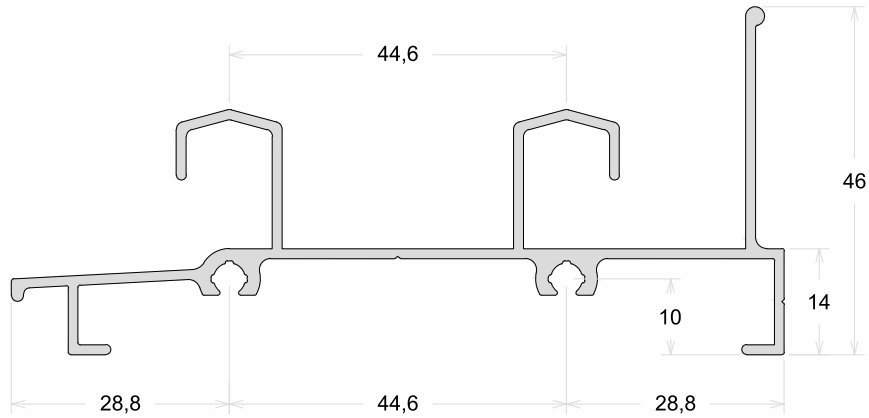

PLG-159	Marco Inferior
Peso (Kg/m)	Perfis De Encaixe:
1,099	PLG-111

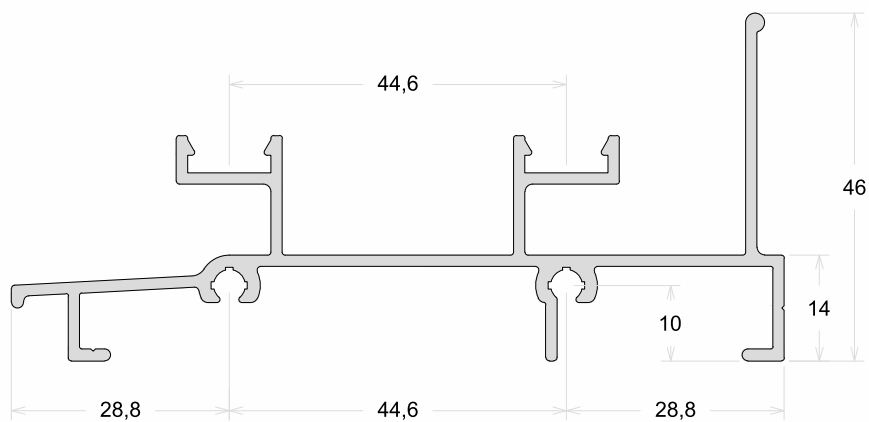

PLG-004	Travessa Intermediária Bandeira
Peso (Kg/m)	Perfis De Encaixe:
1,774	

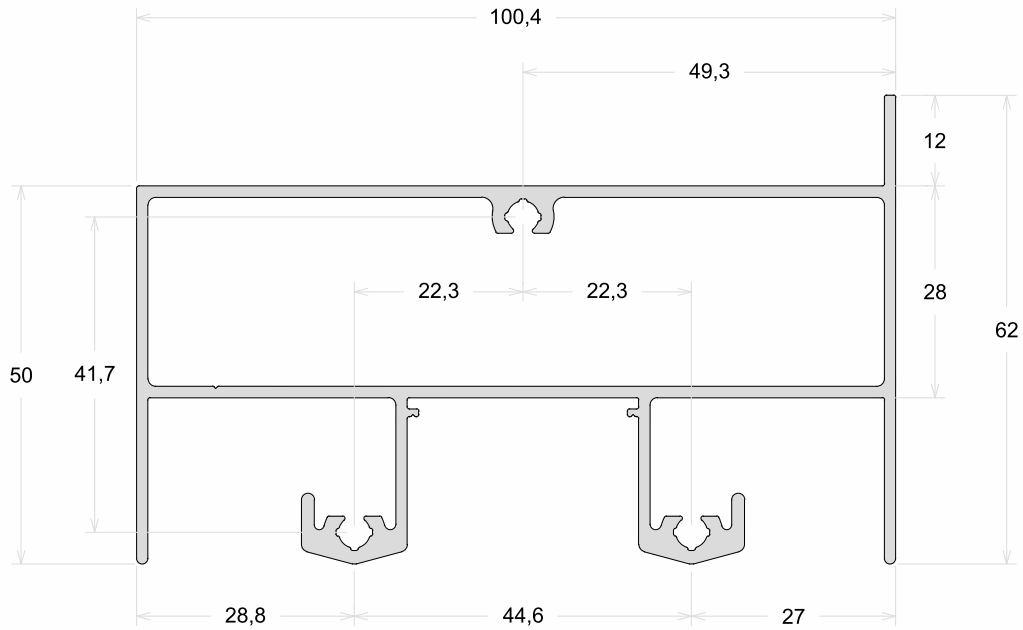

PLG-117	Travessa Intermediária Peitoril
Peso (Kg/m)	Perfis De Encaixe: PLG-111
1,939	

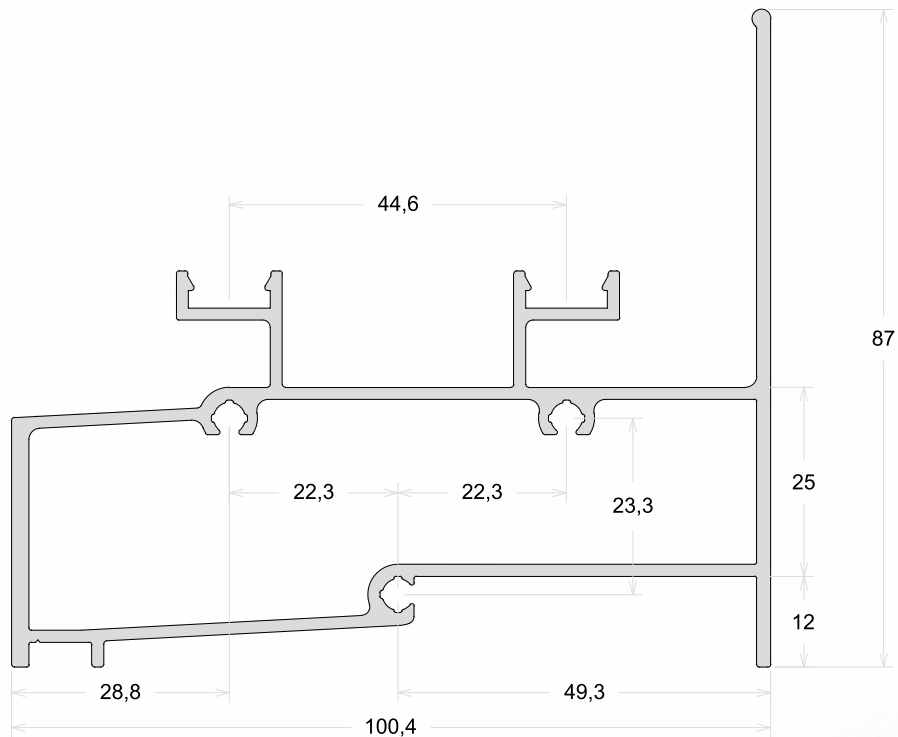

PLG-003	Marco Bandeira / Peitoril
Peso (Kg/m)	Perfis De Encaixe:
0,679	

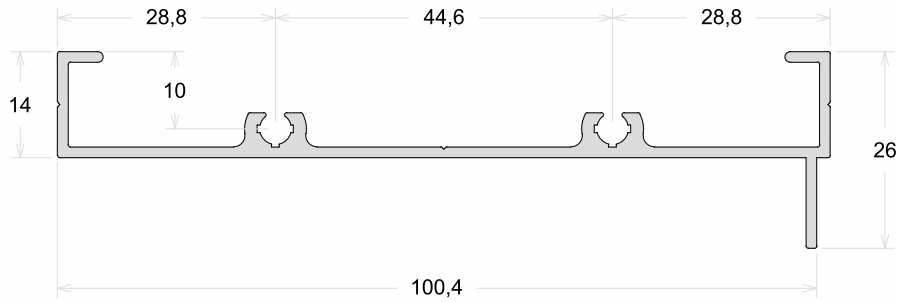

PLG-002	Marco Lateral Liso
Peso (Kg/m)	Perfis De Encaixe:
0,536	



PLG-045	Marco Lateral
Peso (Kg/m)	Perfis De Encaixe:
0,898	

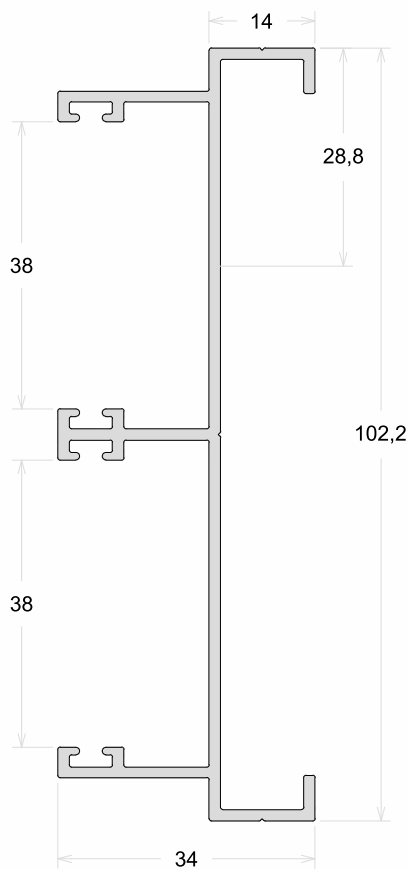

PLG-124	Marco Lateral
Peso (Kg/m)	Perfis De Encaixe:
0,702	

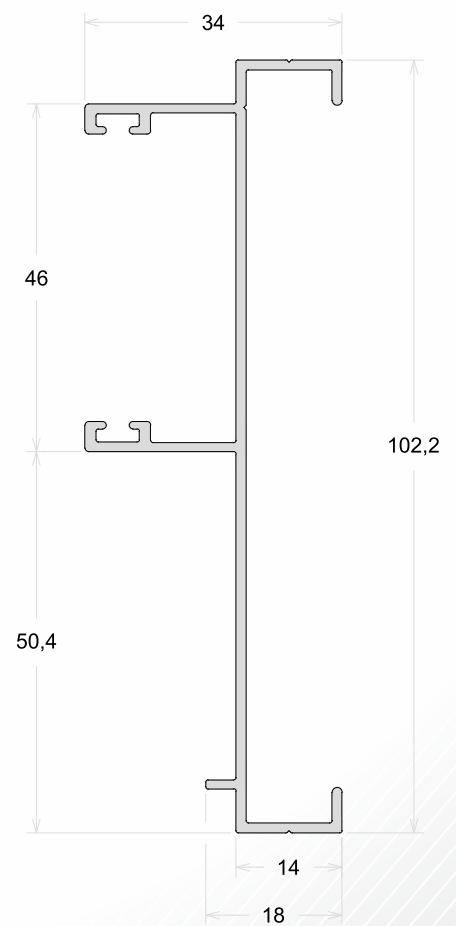

PLG-176	Coluna / Travessa
Peso (Kg/m)	Perfis De Encaixe:
1,420	

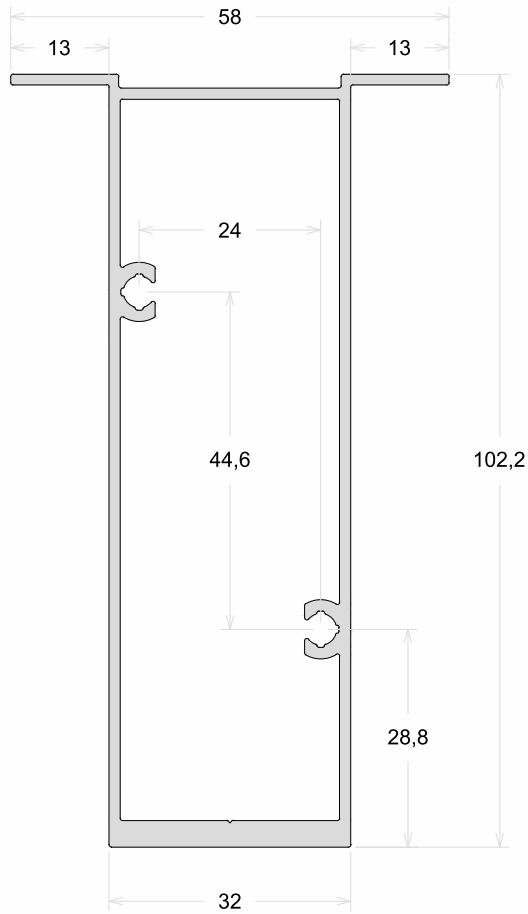

PLG-062	Marco Superior
Peso (Kg/m)	Perfis De Encaixe:
1,590	

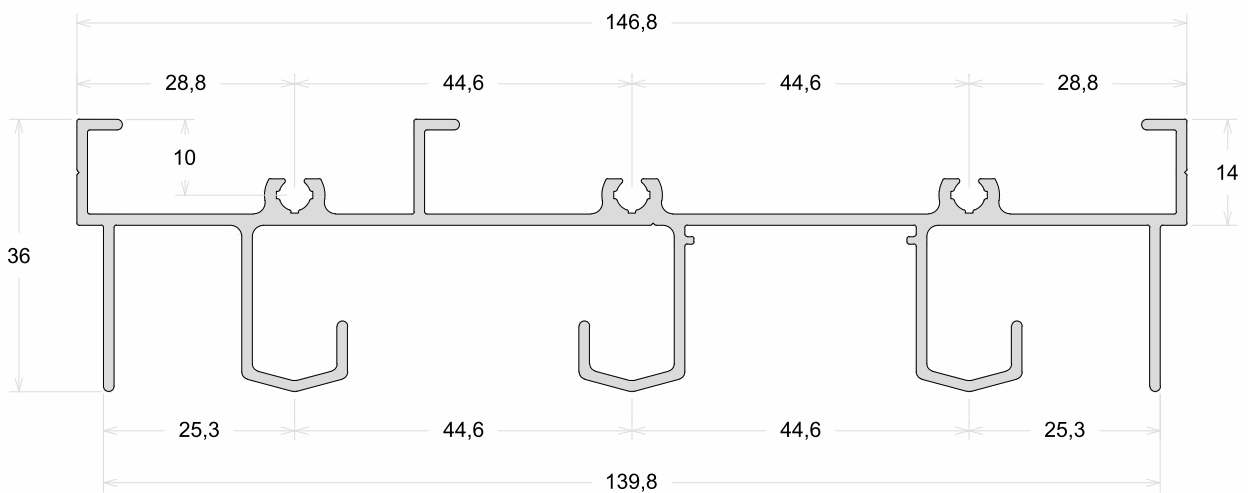

PLG-066	Marco Inferior
Peso (Kg/m)	Perfis De Encaixe:
1,417	

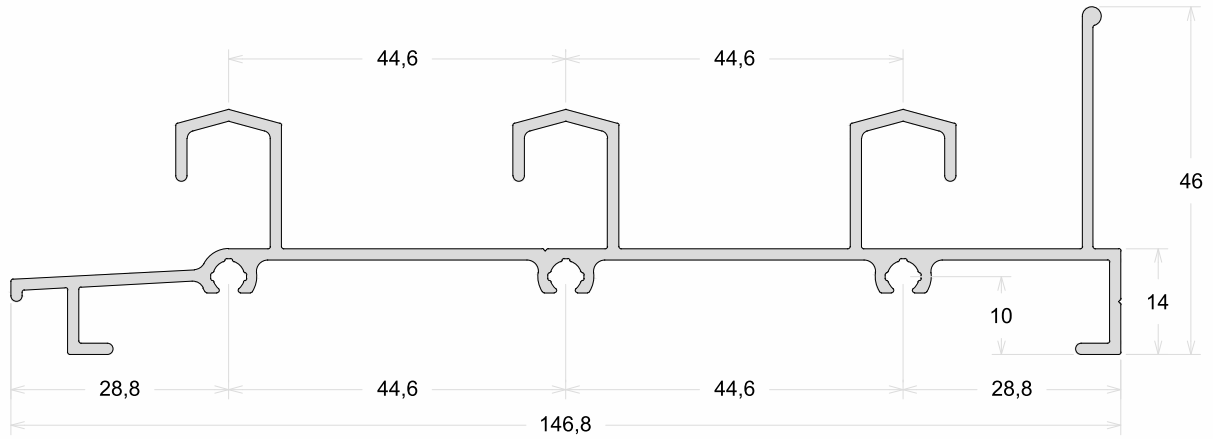

PLG-116	Marco Inferior
Peso (Kg/m)	Perfis De Encaixe:
1,383	PLG-111

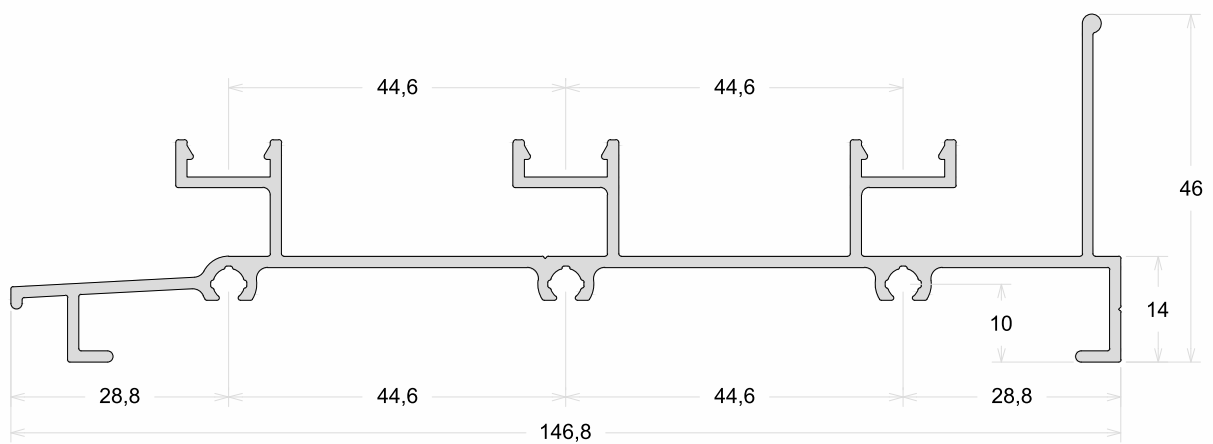

PLG-158	Marco Lateral
Peso (Kg/m)	Perfis De Encaixe:
0,915	

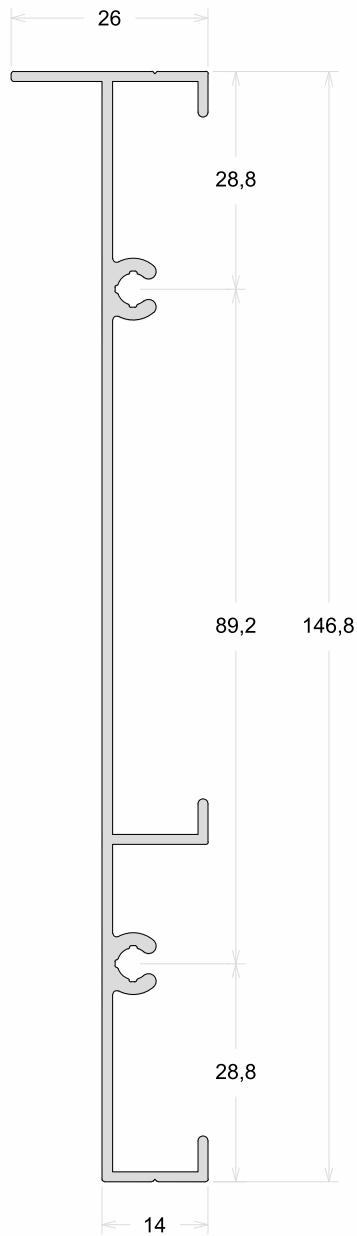

PLG-064	Marco Lateral
Peso (Kg/m)	Perfis De Encaixe:
1,250	

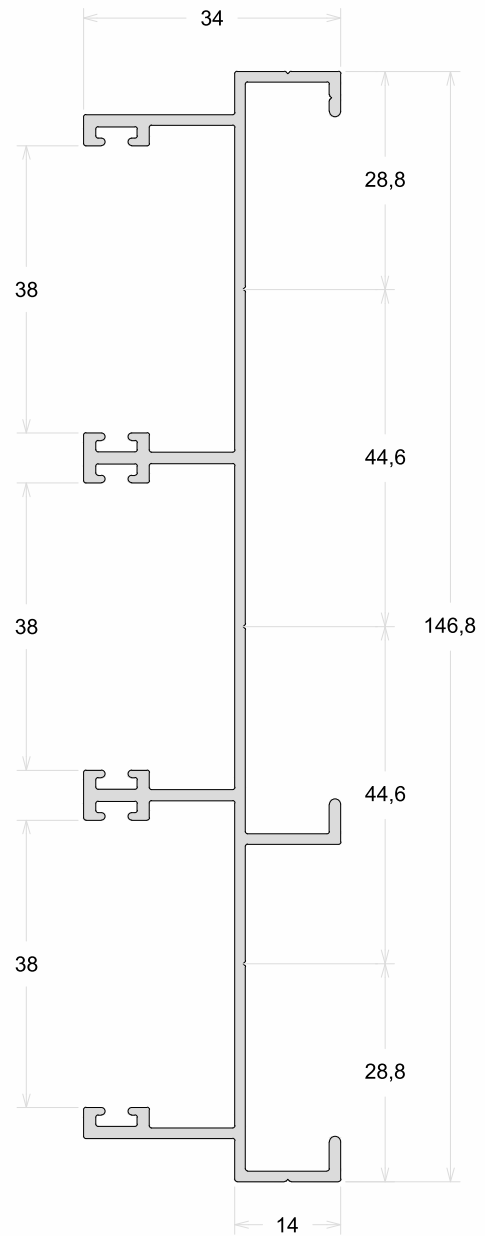

PLG-070	Marco Superior
Peso (Kg/m)	Perfis De Encaixe:
2,088	

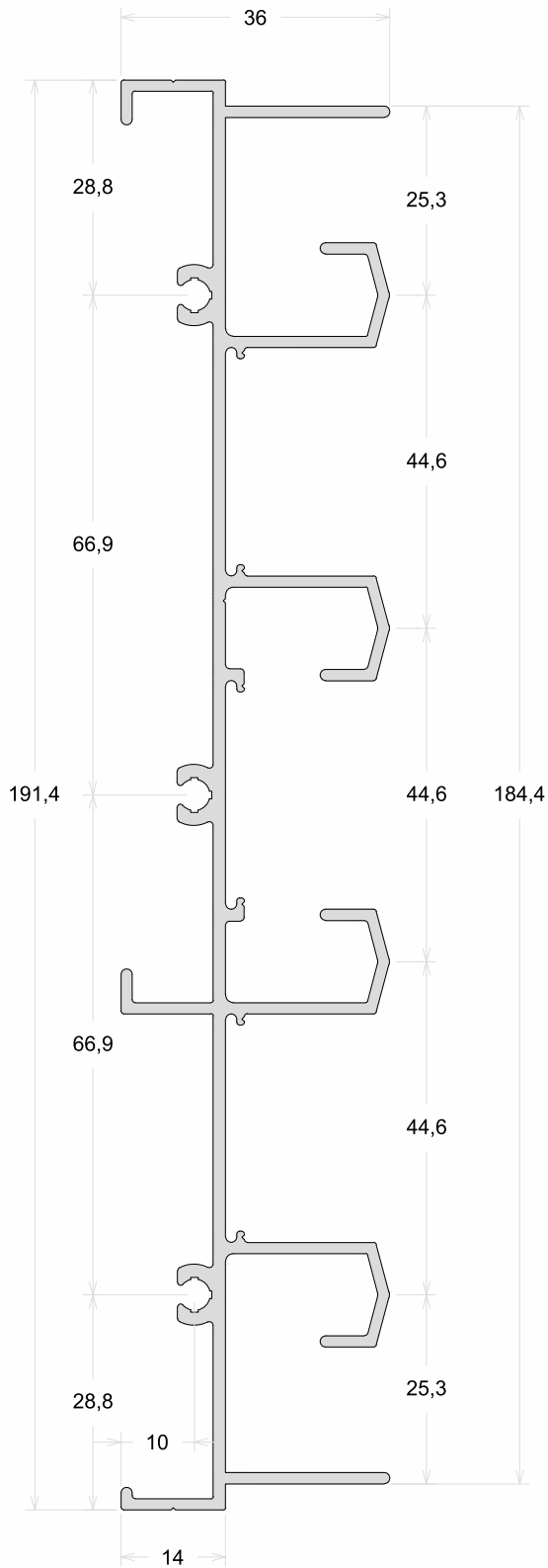

PLG-160	Marco Inferior
Peso (Kg/m)	Perfis De Encaixe:
1,906	PLG-160

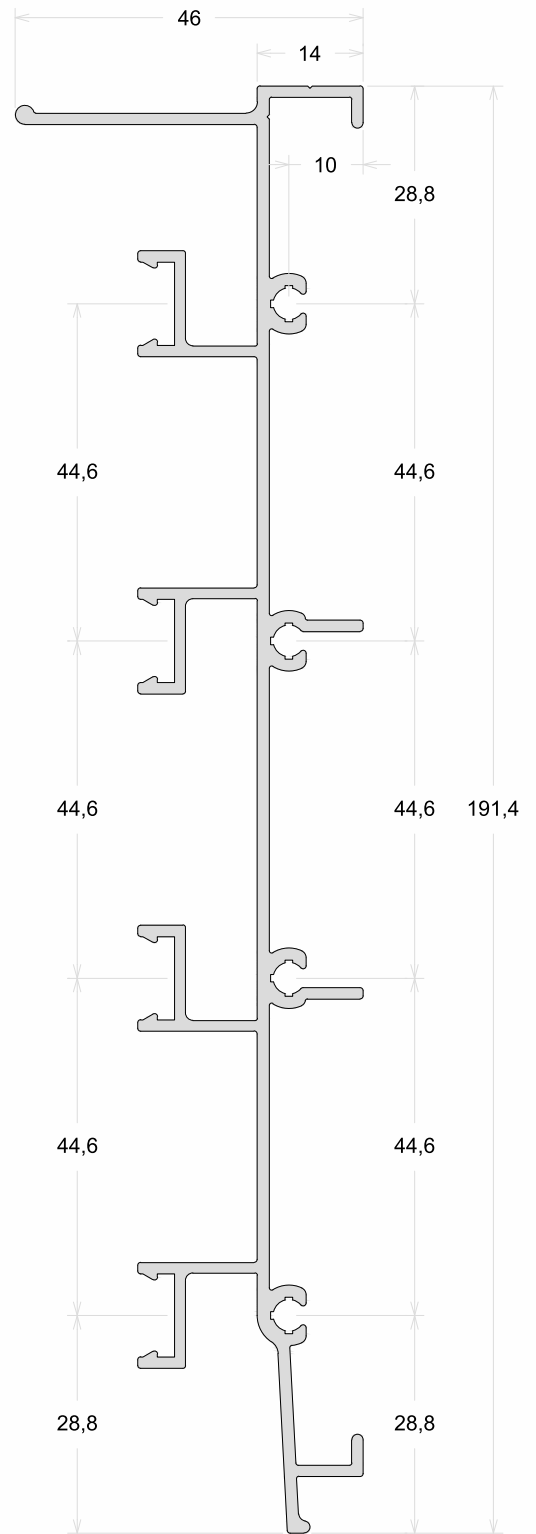

PLG-072	Marco Lateral
Peso (Kg/m)	Perfis De Encaixe:
1,148	

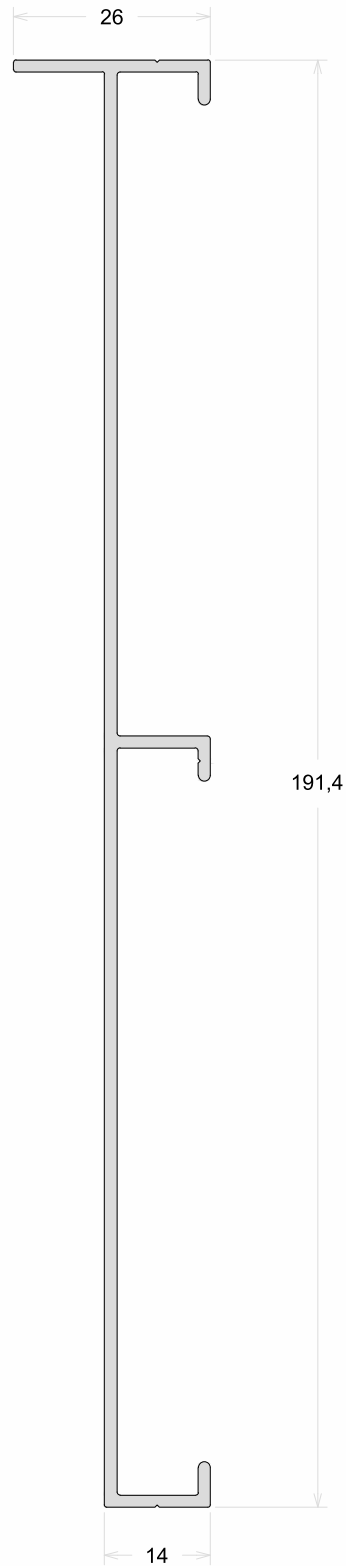

PLG-188	Mata Junta Central e Lateral
Peso (Kg/m)	Perfis De Encaixe:
0,389	

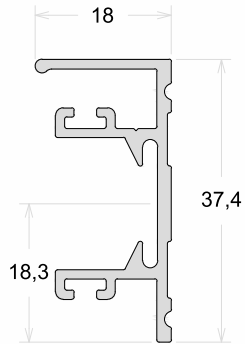

PLG-028	Mata Junta Lateral
Peso (Kg/m)	Perfis De Encaixe:
0,374	

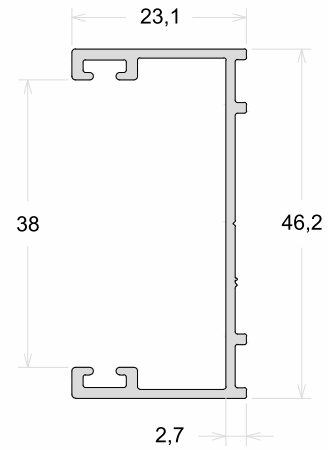

PLG-111	Click Do Trilho Inferior
Peso (Kg/m)	Perfis De Encaixe:
0,095	

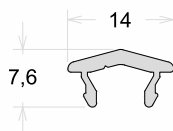

PLG-046	Tampa Do Marco Lateral
Peso (Kg/m)	Perfis De Encaixe:
0,204	

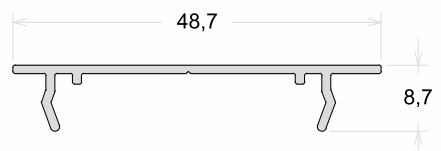

PLG-006 Folha Horizontal

Peso (Kg/m): 0,595

Perfis De Encaixe: BG-057 / PLG-059 / PLG-027 / PLG-015

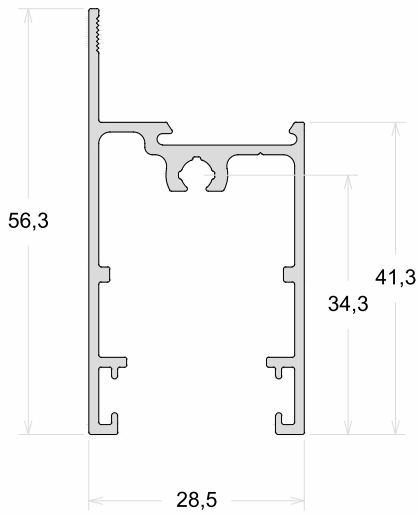

PLG-055 Travessa 64mm

Peso (Kg/m): 0,706

Perfis De Encaixe: BG-057 / PLG-059 / PLG-027 / PLG-015

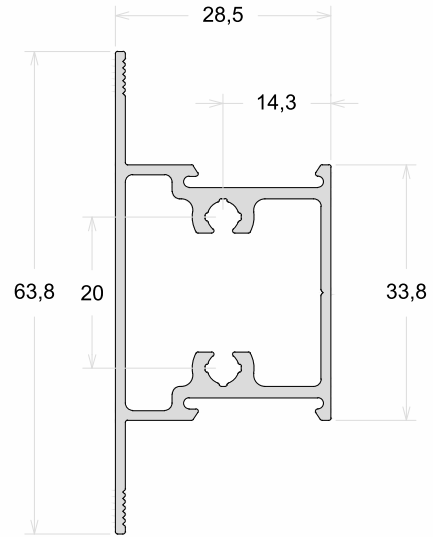

PLG-007 Folha Horizontal - Porta

Peso (Kg/m): 1,160

Perfis De Encaixe: BG-057 / PLG-059 / PLG-027 / PLG-015

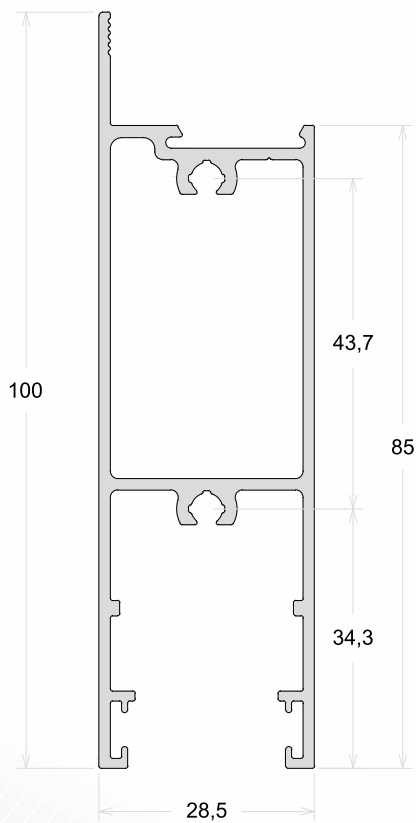

PLG-237 Folha Horizontal

Peso (Kg/m): 1,234

Perfis De Encaixe: BG-057 / PLG-059 / PLG-027 / PLG-015

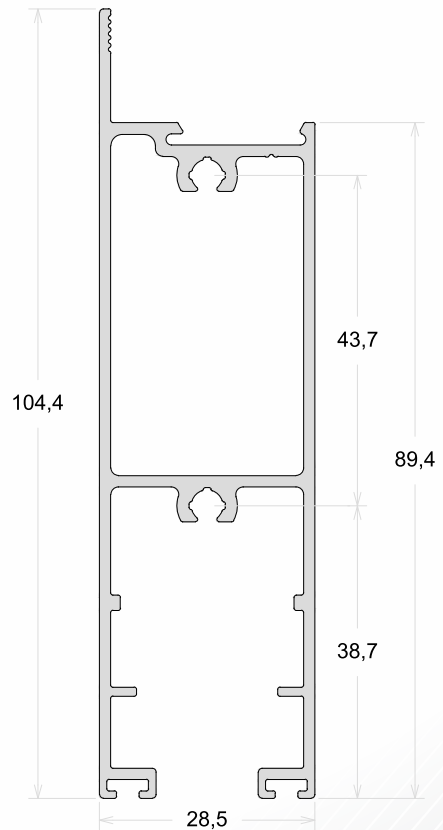

PLG-050 Folha Lateral

Peso (Kg/m) 0,729

Perfis De Encaixe: BG-057 / PLG-059
PLG-164 / PLG-027 / PLG-015
PLG-026

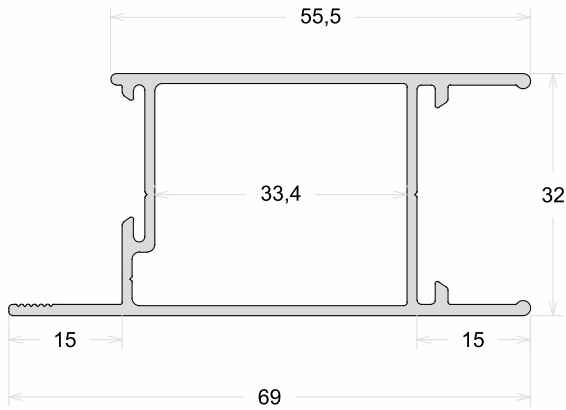

PLG-051 Folha Central

Peso (Kg/m) 0,830

Perfis De Encaixe: BG-057 / PLG-059
PLG-164 / PLG-027 / PLG-015
PLG-026

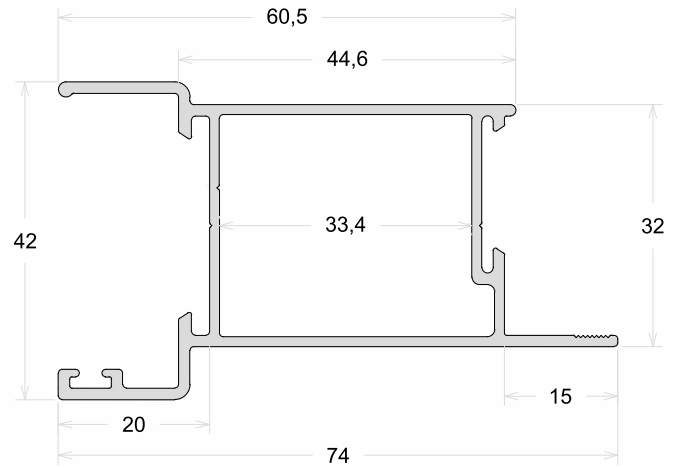

PLG-017 Folha Lateral Com Reforço

Peso (Kg/m) 1,005

Perfis De Encaixe: BG-057 / PLG-059
PLG-164 / PLG-027 / PLG-015
PLG-026

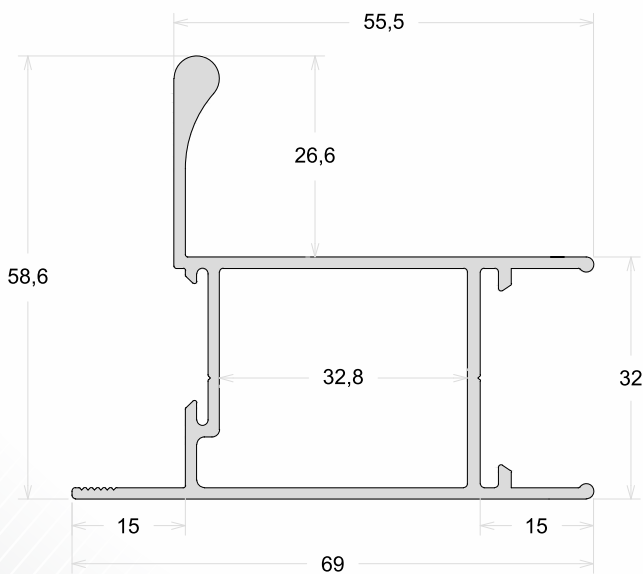

PLG-299 Folha Lateral Com Reforço

Peso (Kg/m) 1,193

Perfis De Encaixe:

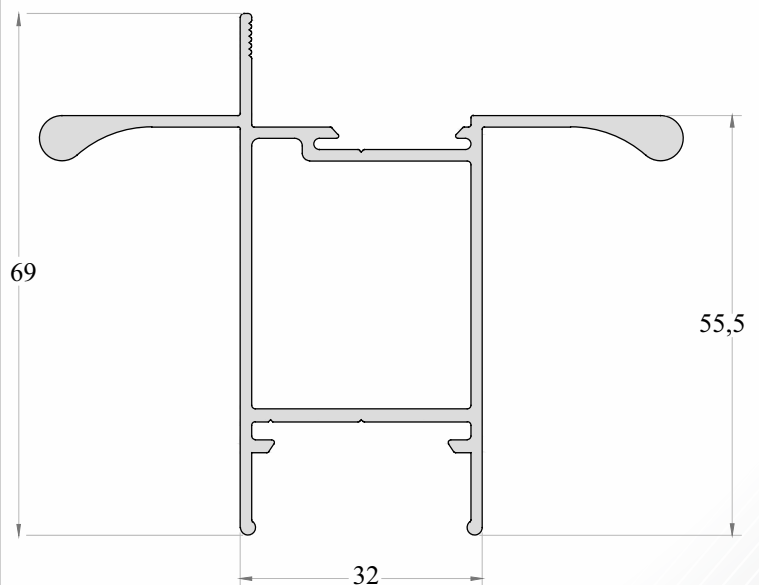

PLG-048	Mão De Amigo Interno
Peso (Kg/m)	Perfis De Encaixe: BG-057 / PLG-059
0,798	PLG-164 / PLG-027 / PLG-015 PLG-026

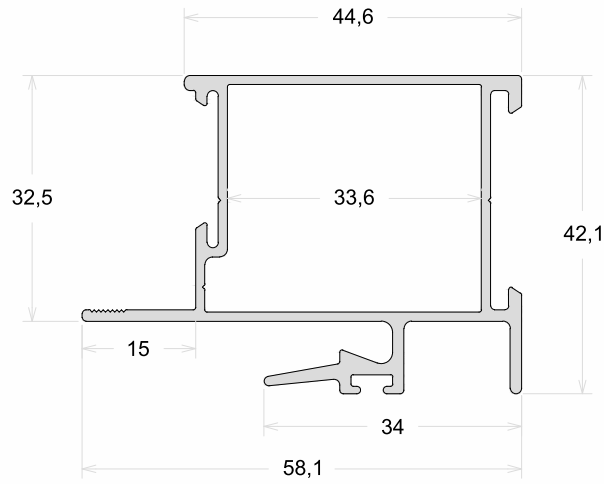

PLG-137	Mão De Amigo Interno Com Reforço
Peso (Kg/m)	Perfis De Encaixe: BG-057 / PLG-059
1,452	PLG-164 / PLG-027 / PLG-015 PLG-026

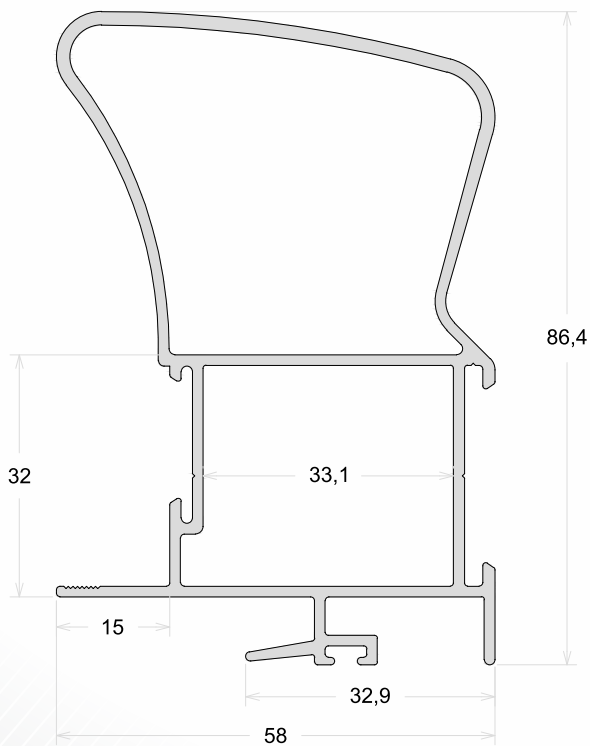

PAT-021	Mão De Amigo Interno Com Reforço
Peso (Kg/m)	Perfis De Encaixe: BG-057 / PLG-059
1,619	PLG-164 / PLG-027 / PLG-015 PLG-026

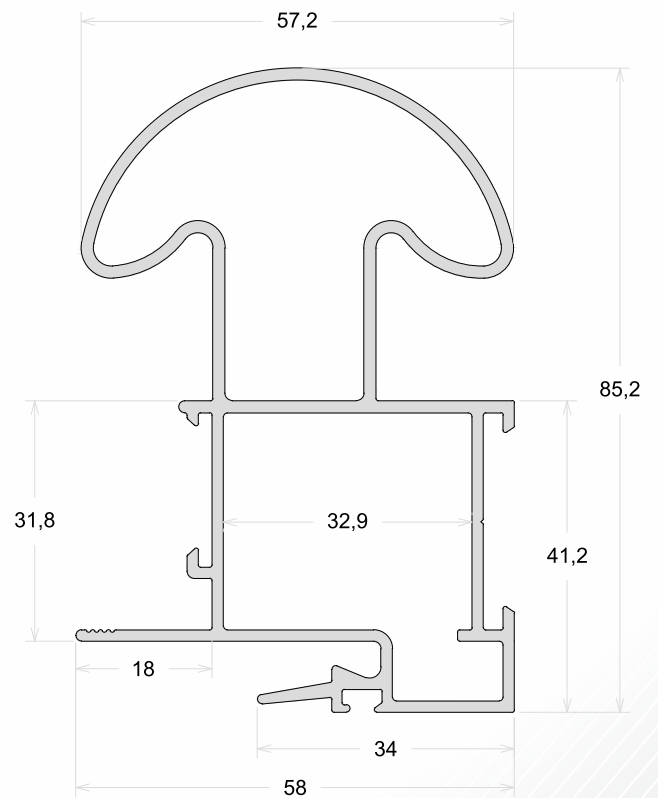

PLG-049 Mão De Amigo Externo

Peso (Kg/m) 0,815

Perfis De Encaixe: BG-057 / PLG-059
PLG-164 / PLG-027 / PLG-015
PLG-026

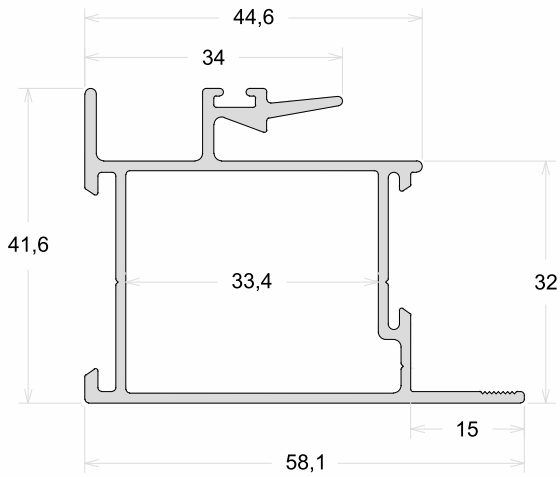

PLG-140 Mão De Amigo Externo Com Reforço

Peso (Kg/m) 1,452

Perfis De Encaixe: BG-057 / PLG-059
PLG-164 / PLG-027 / PLG-015
PLG-026

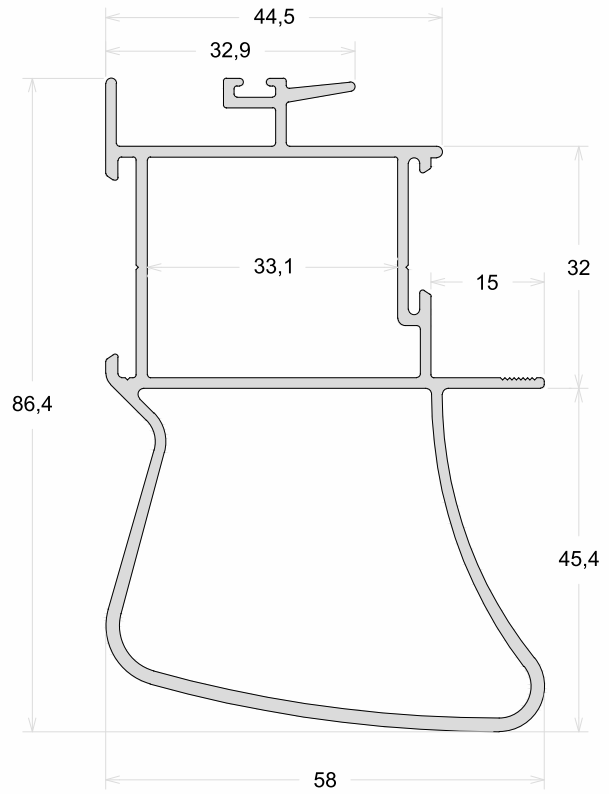

PLG-162 Mão De Amigo Central

Peso (Kg/m) 0,967

Perfis De Encaixe: BG-057 / PLG-059
PLG-164 / PLG-027 / PLG-015
PLG-026

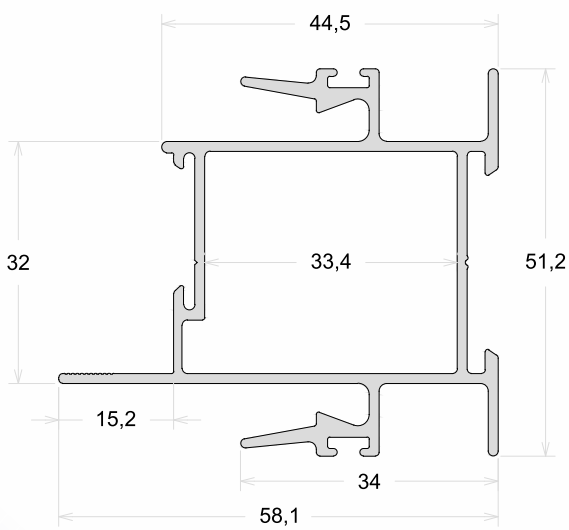

PLG-242 Folha Lateral

Peso (Kg/m) 0,879

Perfis De Encaixe: BG-057 / PLG-059
PLG-164 / PLG-027 / PLG-015
PLG-026

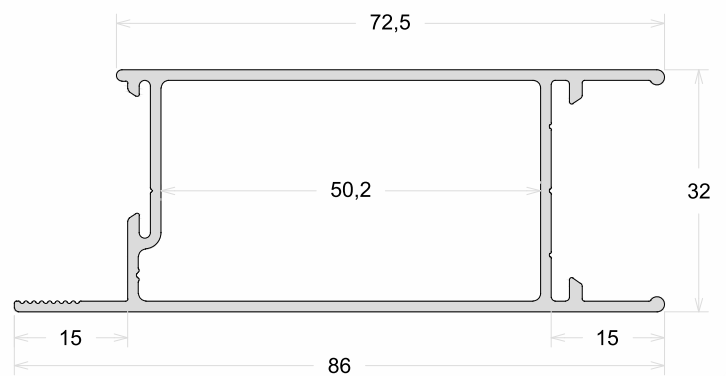

PLG-241	Mão De Amigo Interno
Peso (Kg/m)	Perfis De Encaixe: BG-057 / PLG-059
1,024	PLG-164 / PLG-027 / PLG-015 PLG-026

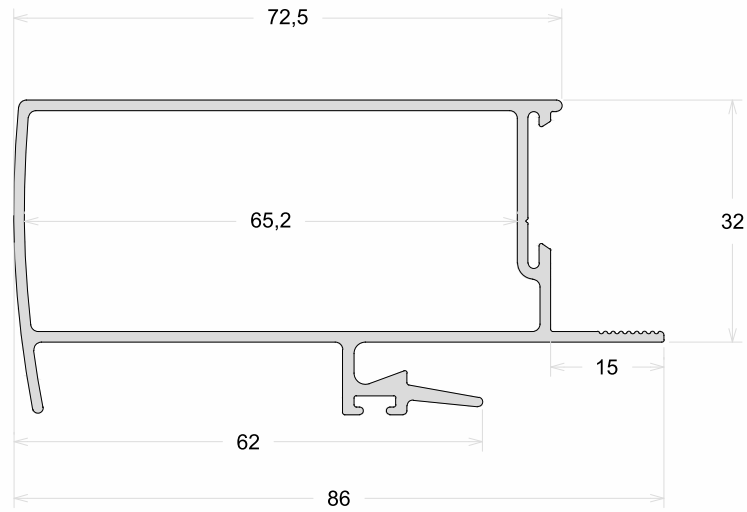

PLG-240	Mão De Amigo Externo
Peso (Kg/m)	Perfis De Encaixe: BG-057 / PLG-059
1,022	PLG-164 / PLG-027 / PLG-015 PLG-026

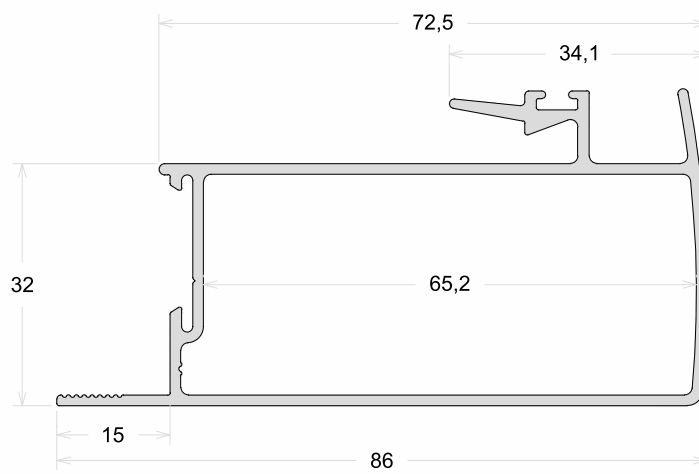

PLG-130	Folha Horizontal Sem Bagueete
Peso (Kg/m)	Perfis De Encaixe:
0,630	

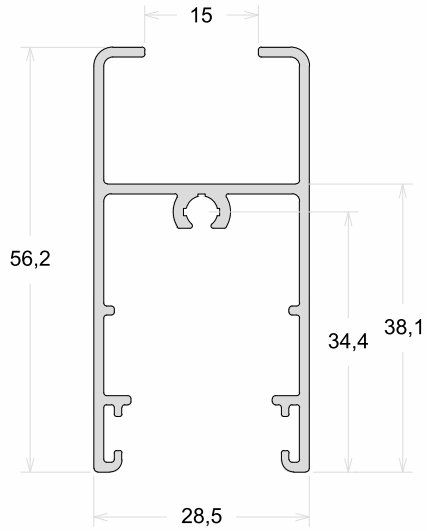

PLG-131	Travessa 64mm Sem Bagueete
Peso (Kg/m)	Perfis De Encaixe:
0,777	

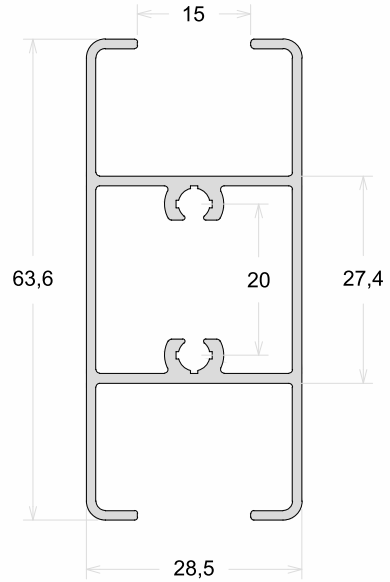

PLG-129	Folha Horizontal - Porta Sem Bagueete
Peso (Kg/m)	Perfis De Encaixe:
1,178	

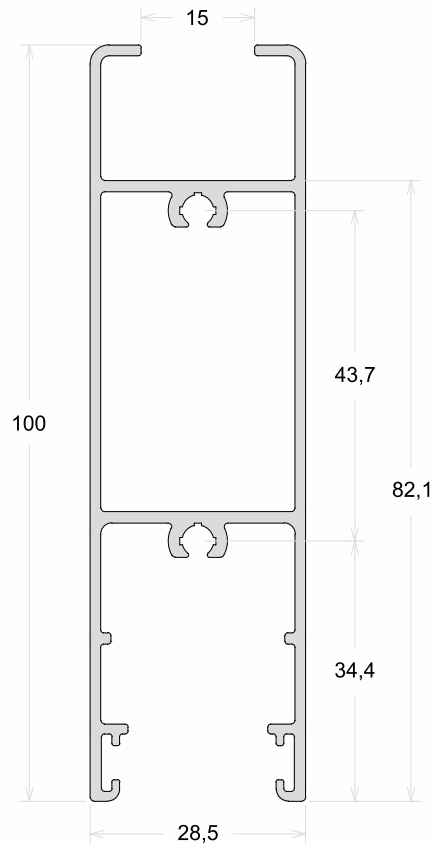

PLG-132	Folha Lateral Sem Bagueete
Peso (Kg/m)	Perfis De Encaixe:
0,799	

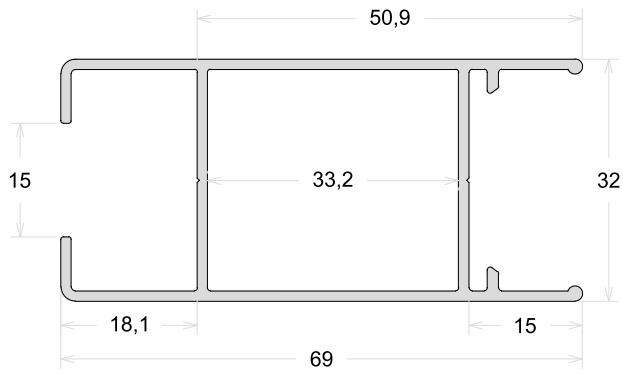

PLG-133	Folha Central Sem Bagueete
Peso (Kg/m)	Perfis De Encaixe:
0,902	

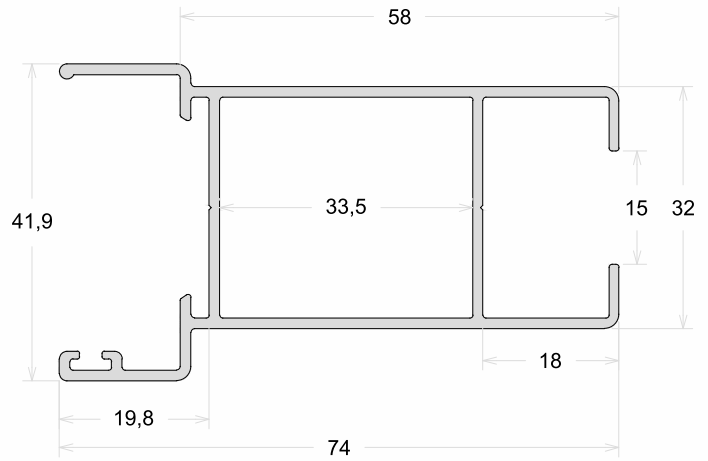

PLG-135	Folha Lateral Com Reforço Sem Bagueete
Peso (Kg/m)	Perfis De Encaixe:
1,519	

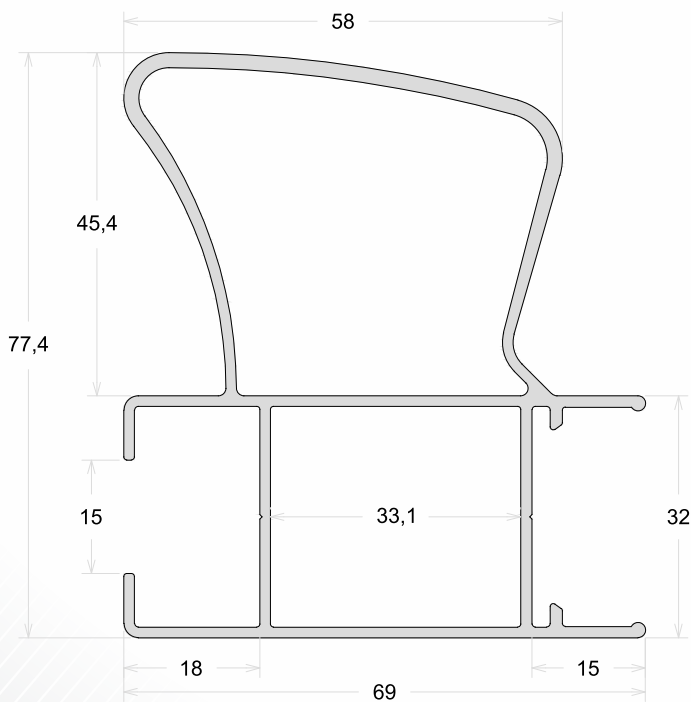

PLG-136	Folha Central Com Reforço Sem Bagueete
Peso (Kg/m)	Perfis De Encaixe:
1,601	

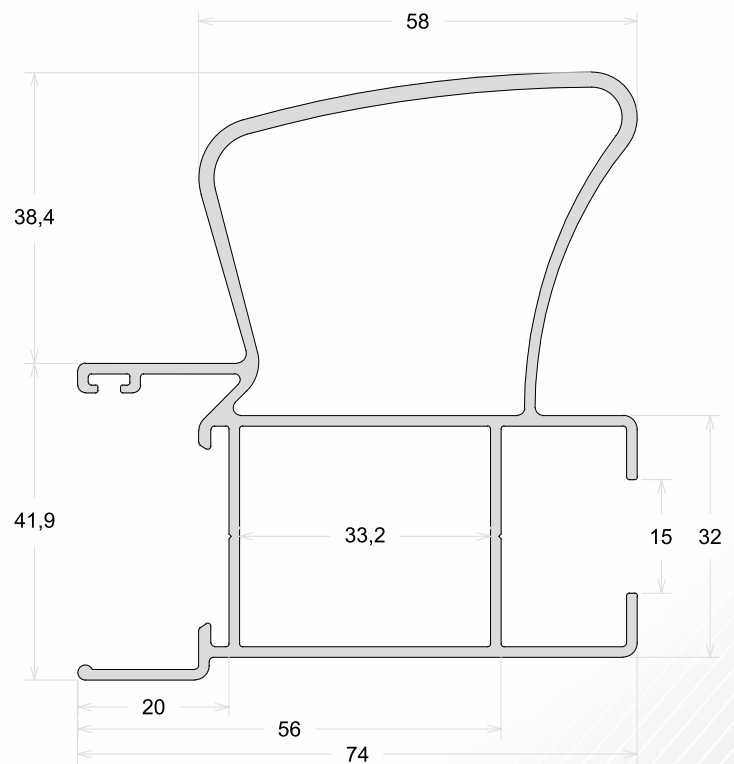

PLG-128	Mão De Amigo Sem Bagueete
Peso (Kg/m)	Perfis De Encaixe:
0,900	

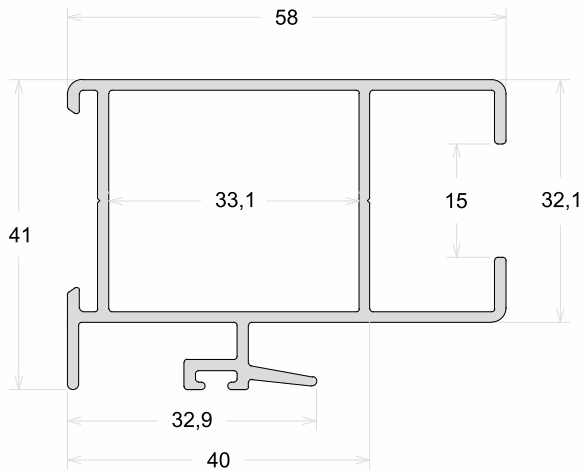

PLG-127	Mão De Amigo Com Reforço Sem Bagueete
Peso (Kg/m)	Perfis De Encaixe:
1,571	

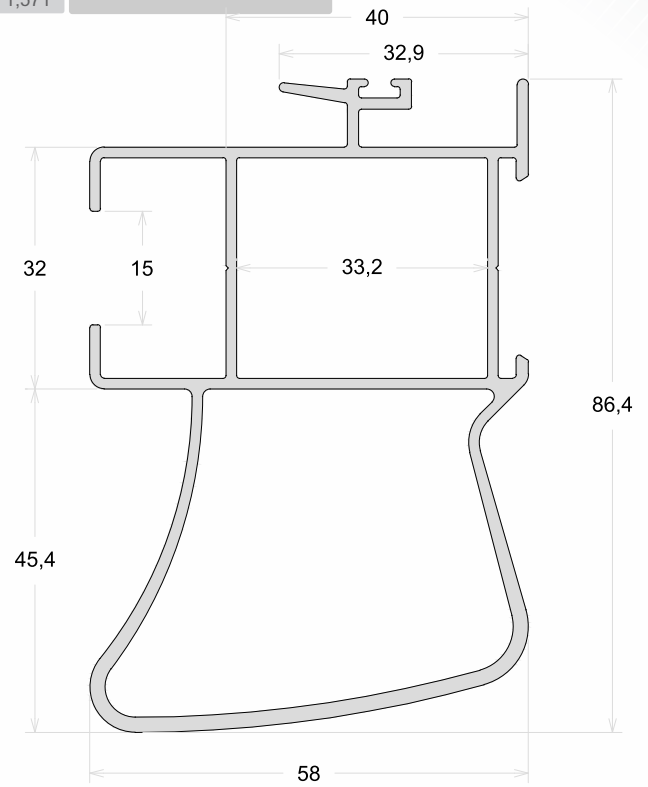

PLG-163	Mão De Amigo Central Sem Bagueete
Peso (Kg/m)	Perfis De Encaixe:
1,050	

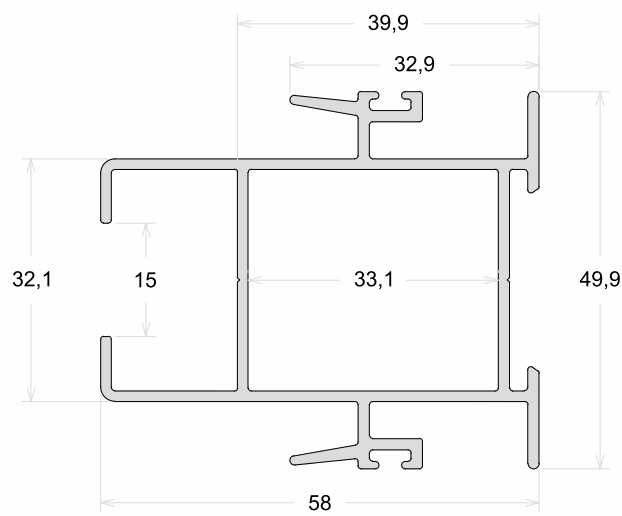

PSU-113	Trilho Inferior
Peso (Kg/m)	Perfis De Encaixe:
0,231	

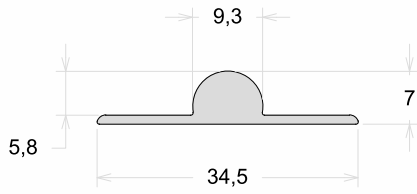

PSU-114	Trilho Inferior
Peso (Kg/m)	Perfis De Encaixe:
0,169	

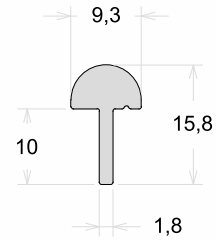

CL-050	Complemento Tela Mosquiteira
Peso (Kg/m)	Perfis De Encaixe:
0,133	

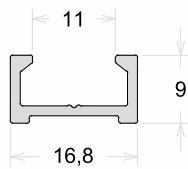

DS-036	Complemento Tela Mosquiteira
Peso (Kg/m)	Perfis De Encaixe:
0,152	

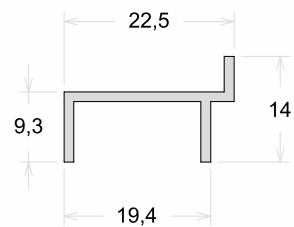

PMN-001	Marco Superior Integrada
Peso (Kg/m)	Perfis De Encaixe:
1,274	

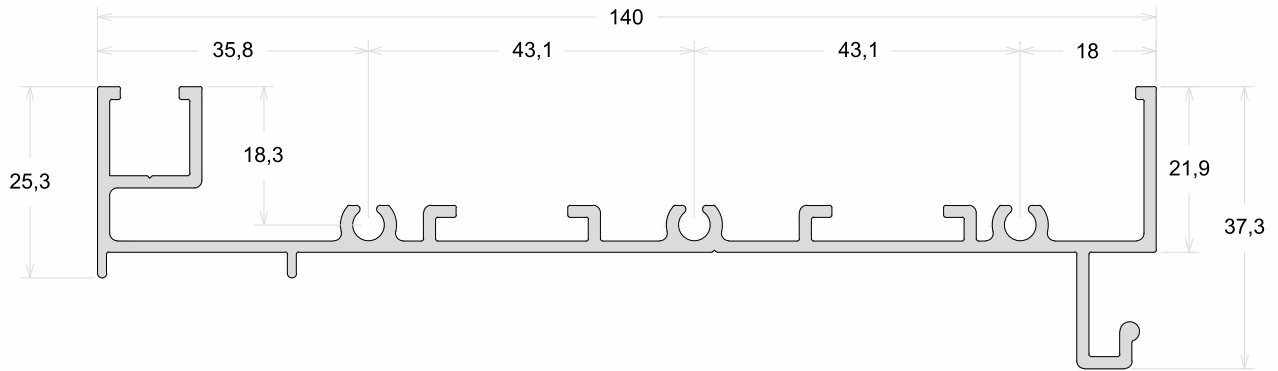

PLG-168	Marco Superior Integrada
Peso (Kg/m)	Perfis De Encaixe:
1,094	

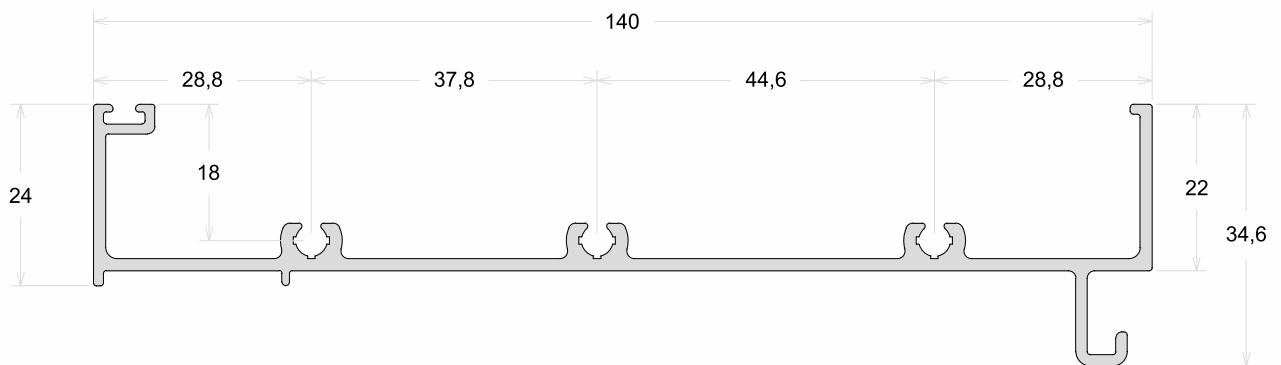

PLG-166	Travessa Intermediária Integrada
Peso (Kg/m)	Perfis De Encaixe:
1,745	

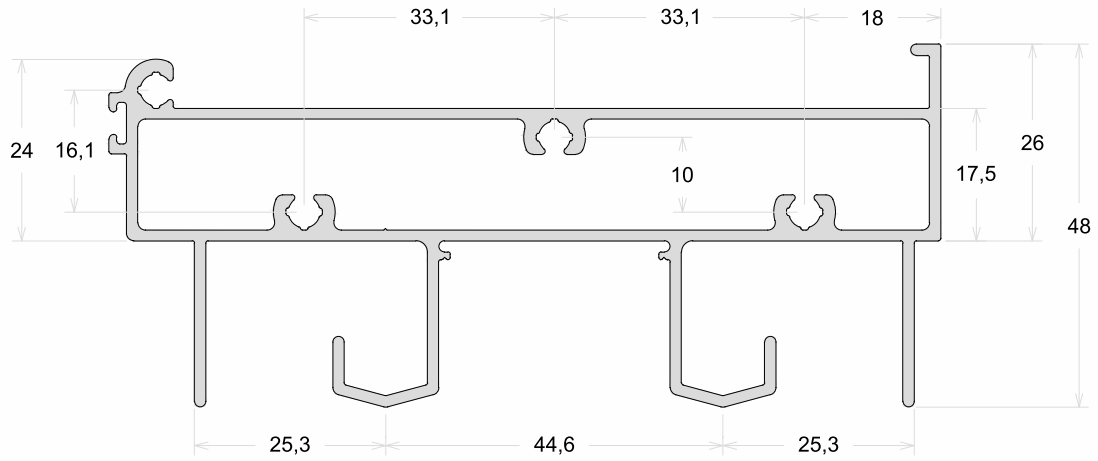

PLG-200	Travessa Intermediária Integrada
Peso (Kg/m)	Perfis De Encaixe:
0,570	

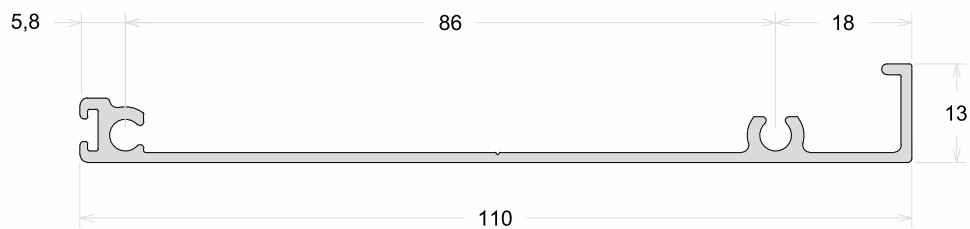

PLG-030	Marco Inferior Integrada
Peso (Kg/m)	Perfis De Encaixe:
1,515	

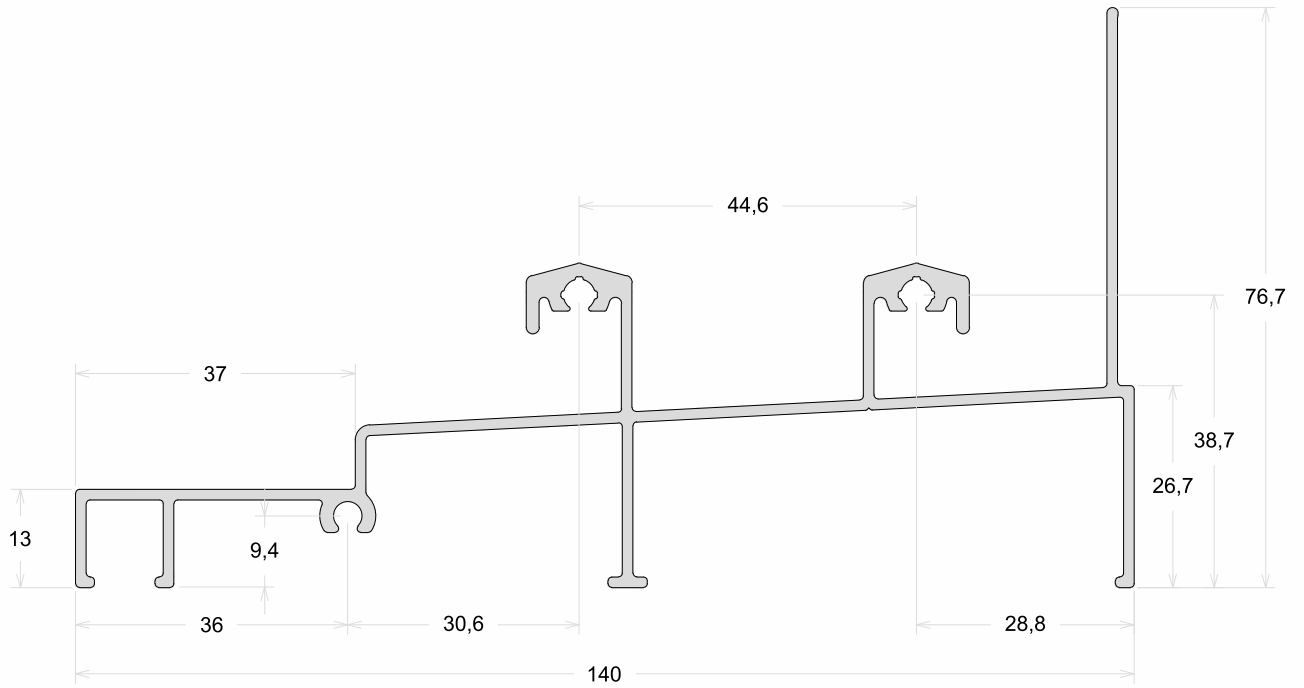

PLG-118	Marco Inferior Integrada
Peso (Kg/m)	Perfis De Encaixe:
1,458	PLG-111

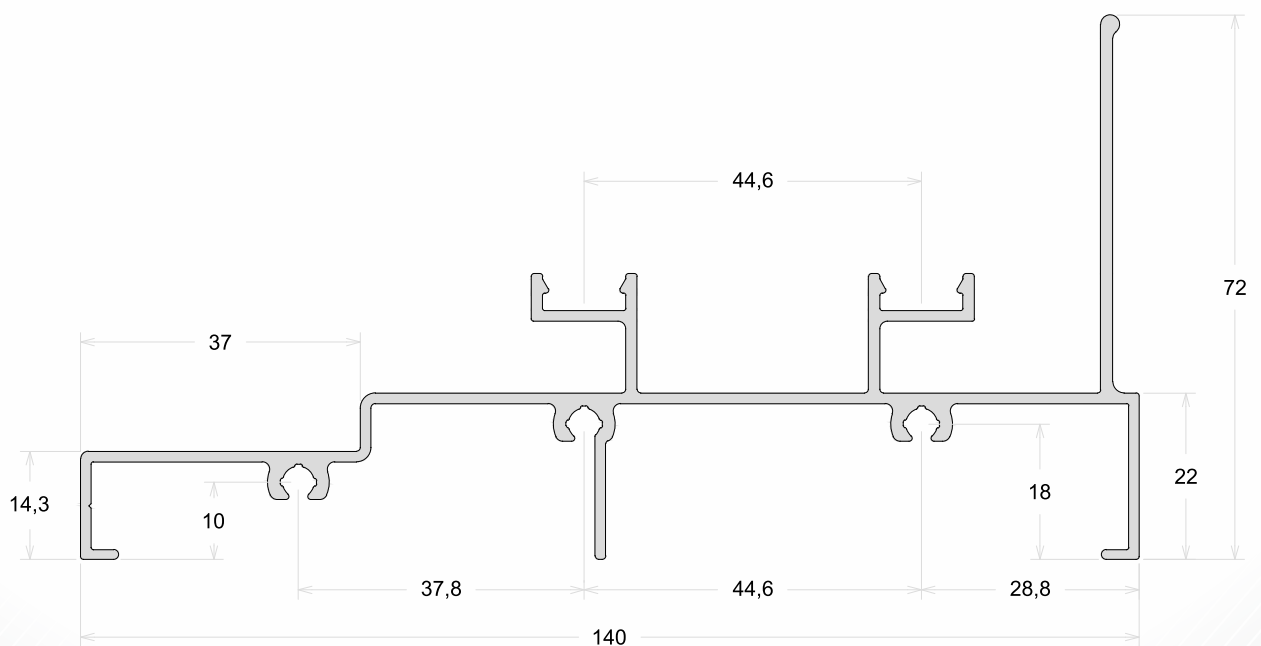

PMN-003	Marco Lateral Integrada
Peso (Kg/m)	Perfis De Encaixe:
0,991	

PLG-170	Marco Lateral Integrada
Peso (Kg/m)	Perfis De Encaixe:
0,746	

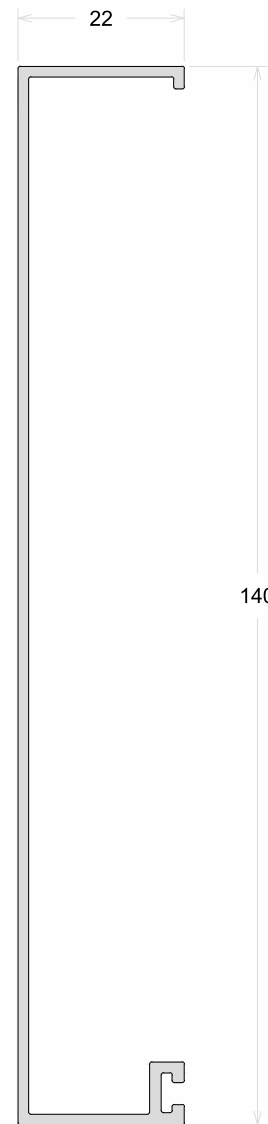
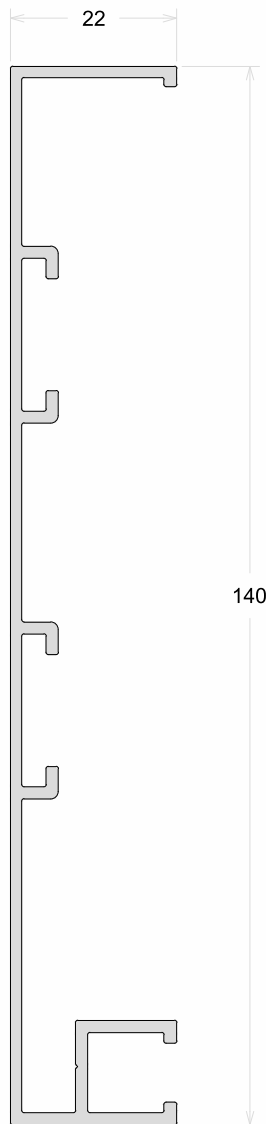

PLG-236	Marco Lateral Integrada
Peso (Kg/m)	Perfis De Encaixe:
1,185	

PMN-050	Marco Lateral Integrada
Peso (Kg/m)	Perfis De Encaixe:
0,651	

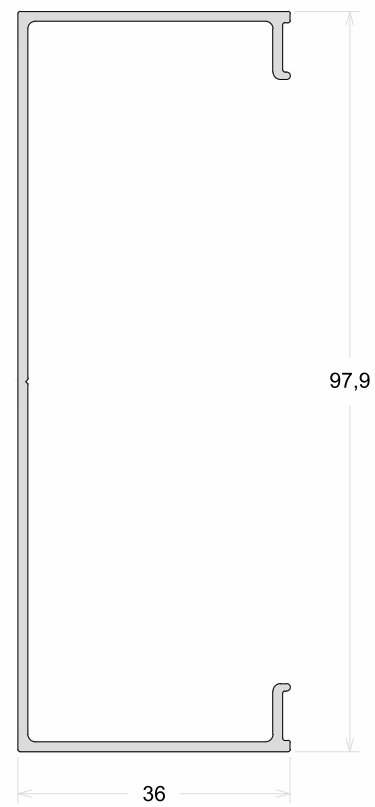
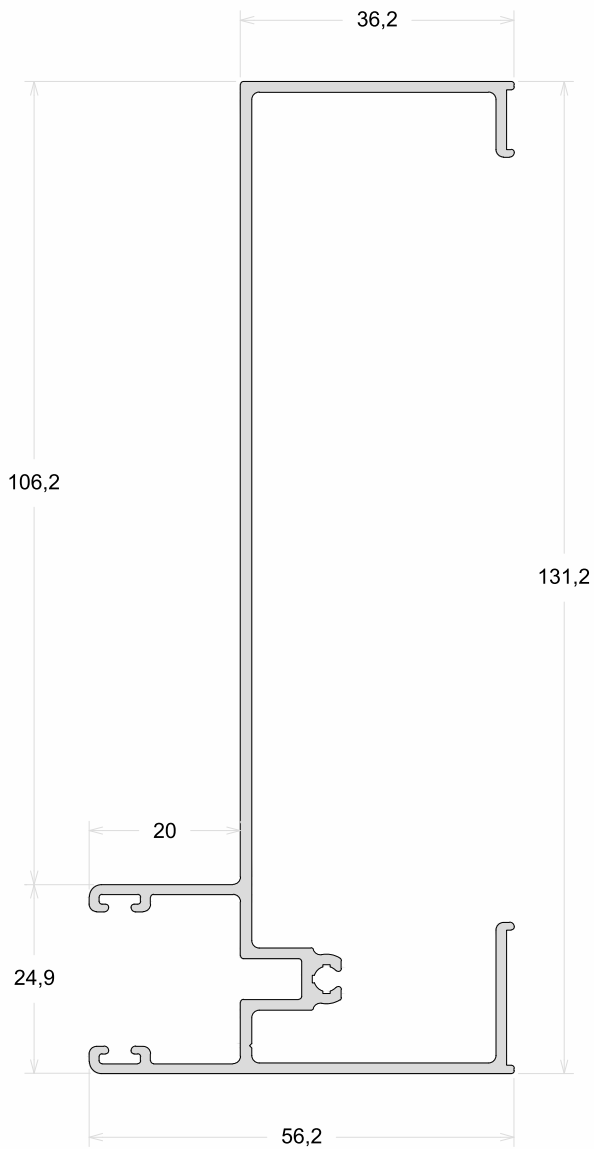

80-041	Marco Superior Integrada
Peso (Kg/m)	Perfis De Encaixe:
1,304	

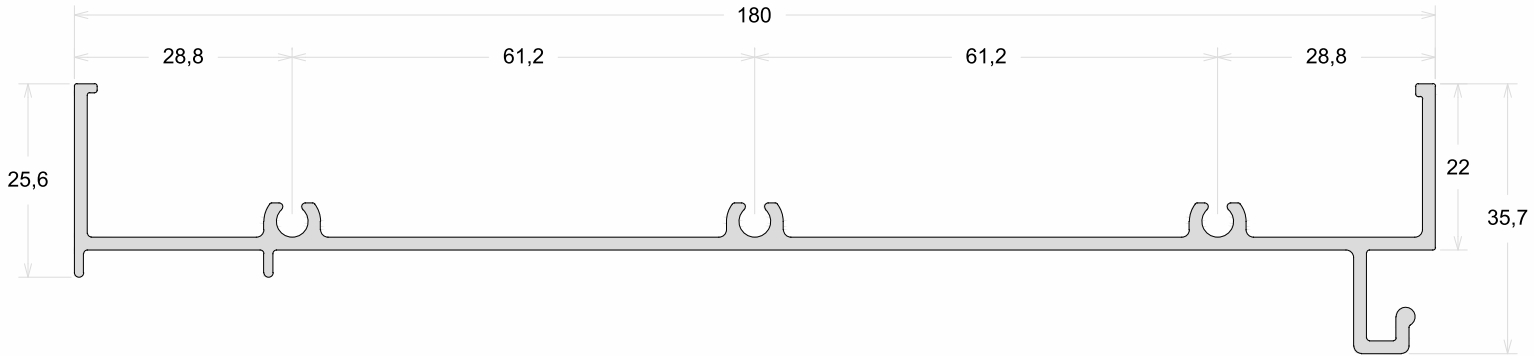

80-034	Travessa Intermediária Integrada
Peso (Kg/m)	Perfis De Encaixe:
2,031	

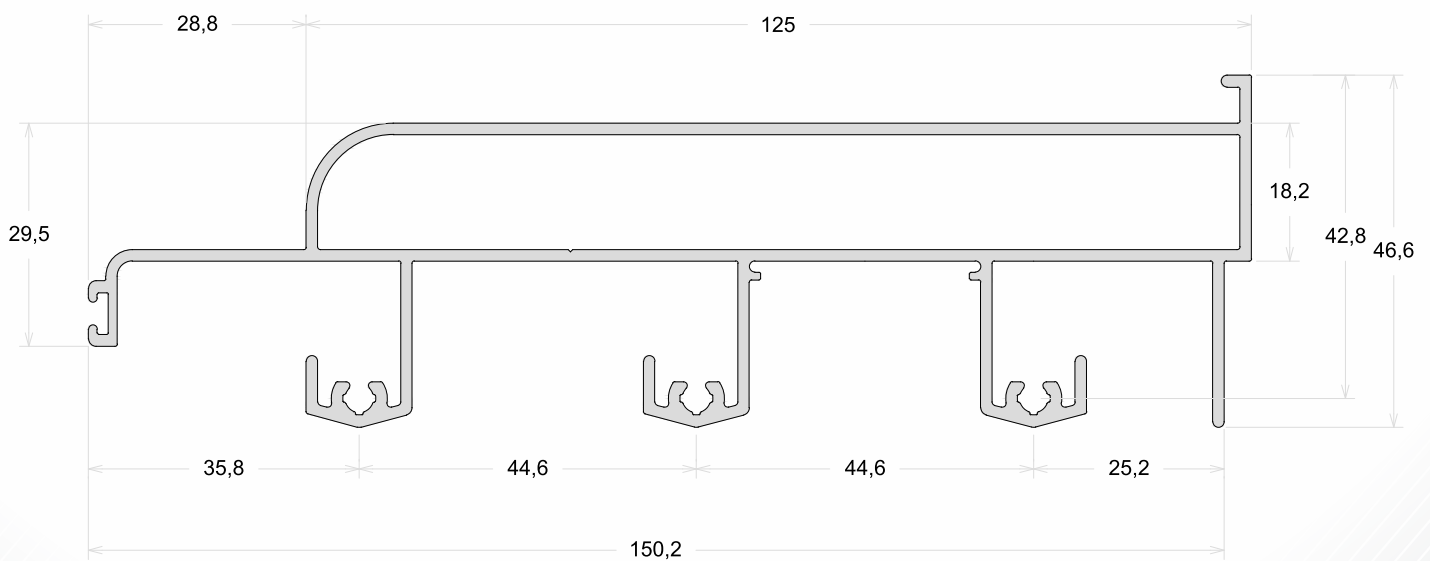

80-035	Marco Lateral Integrada
Peso (Kg/m)	Perfis De Encaixe:
1,031	

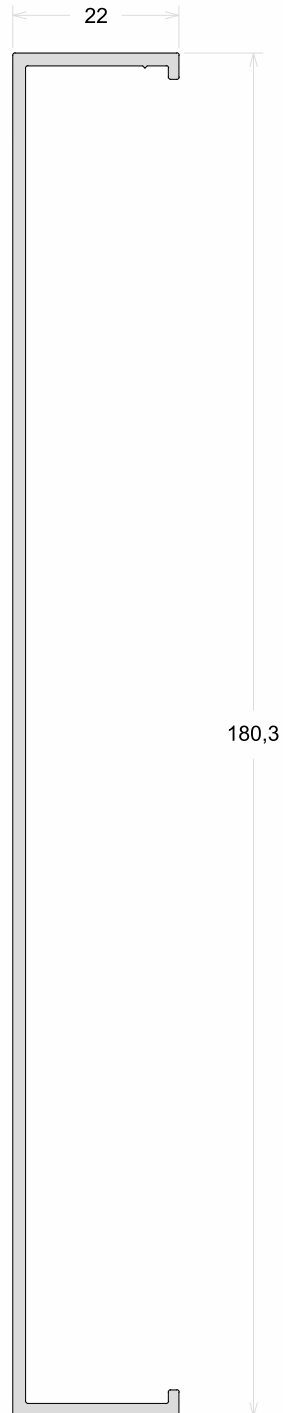

PMH-008	Tampa Externa
Peso (Kg/m)	Perfis De Encaixe:
0,771	

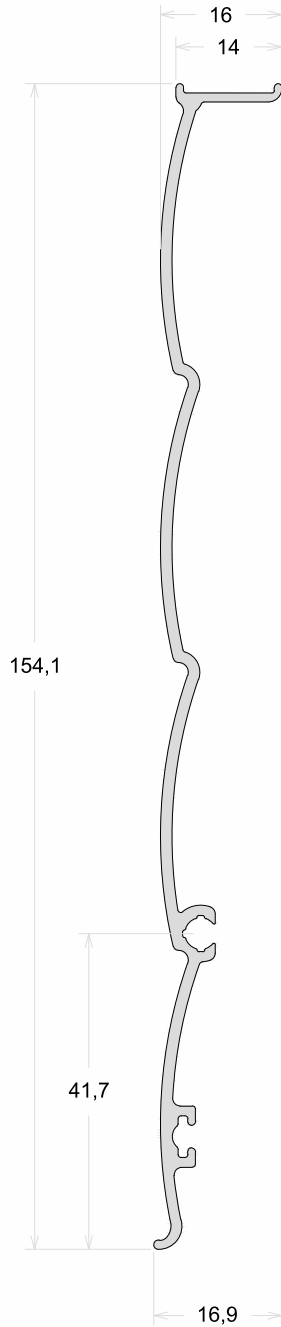

PIT-039	Tampa Externa
Peso (Kg/m)	Perfis De Encaixe:
1,168	

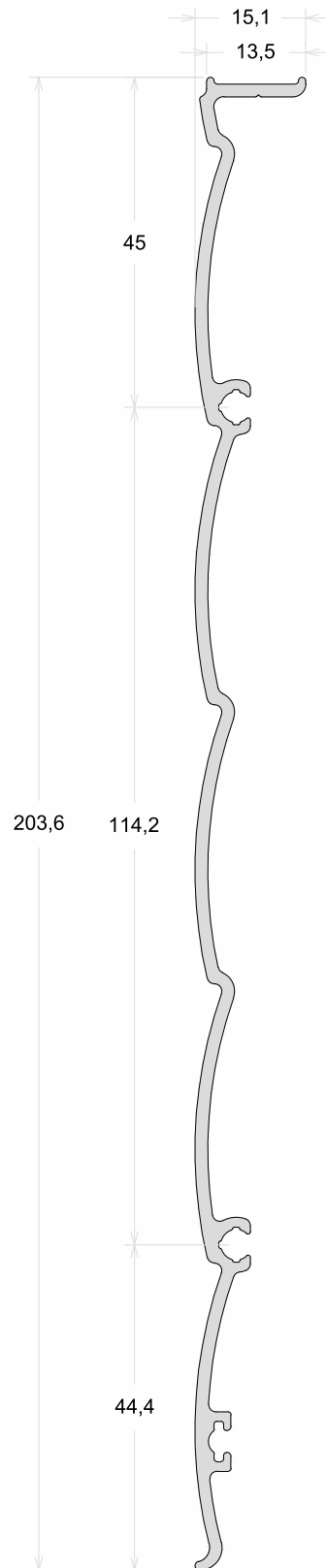

PMN-039	Tampa Externa
Peso (Kg/m)	Perfis De Encaixe:
1,248	

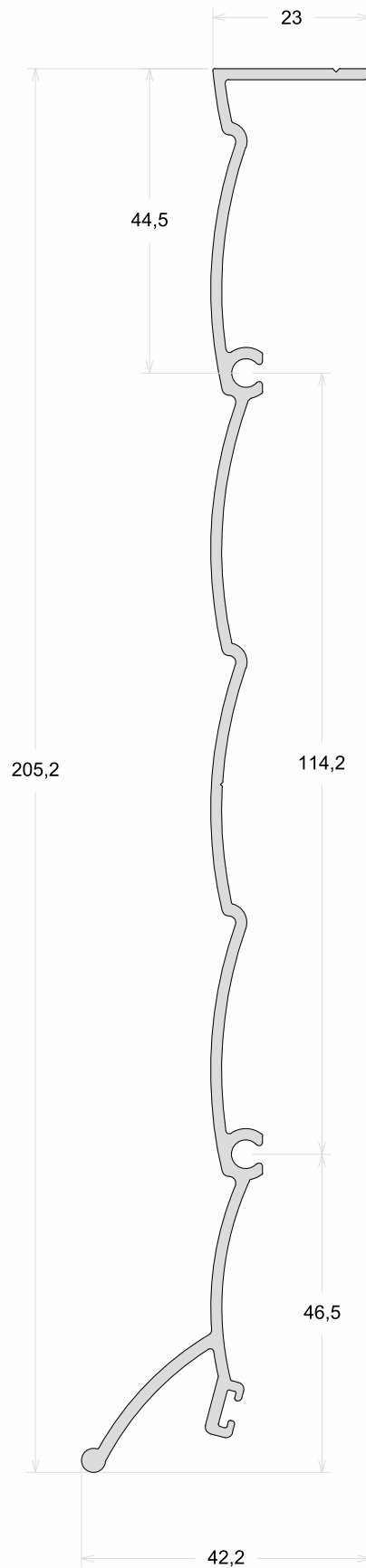

PMH-007	Tampa Interna
Peso (Kg/m)	Perfis De Encaixe:
0,897	

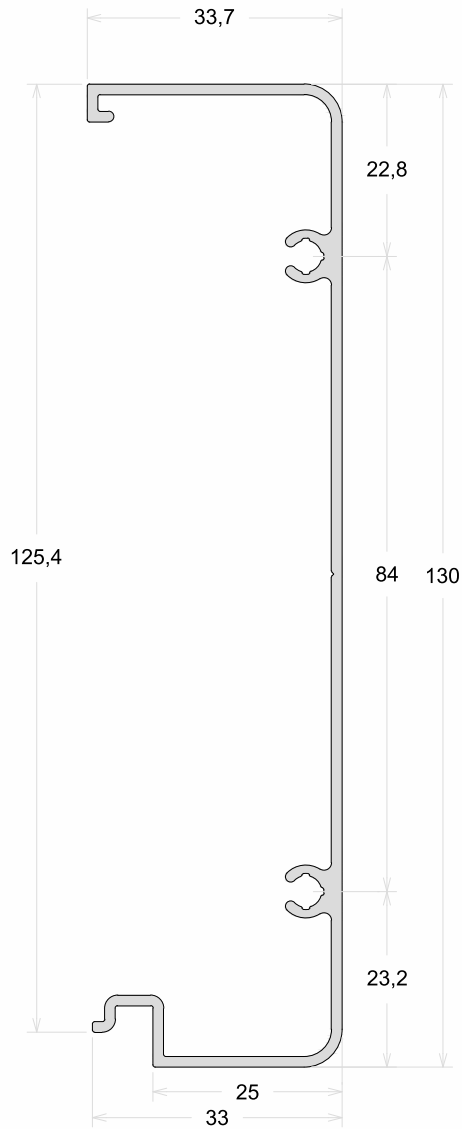

PMN-031	Tampa Interna
Peso (Kg/m)	Perfis De Encaixe:
1,217	

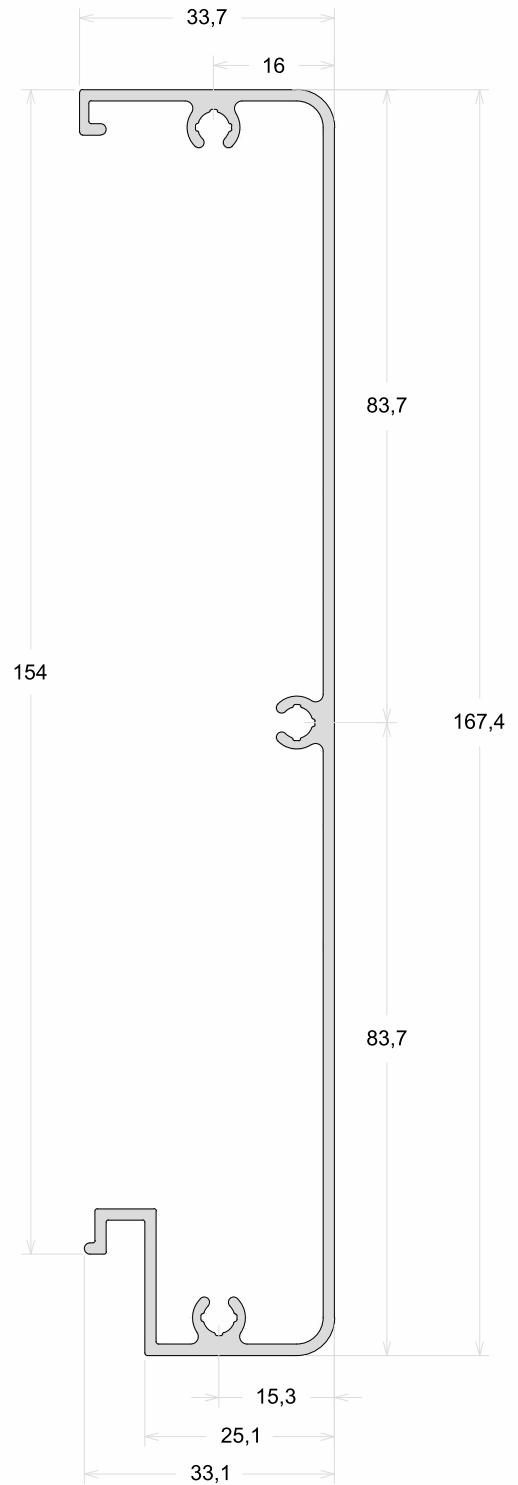

PLG-230	Tampa Interna
Peso (Kg/m)	Perfis De Encaixe:
1,573	

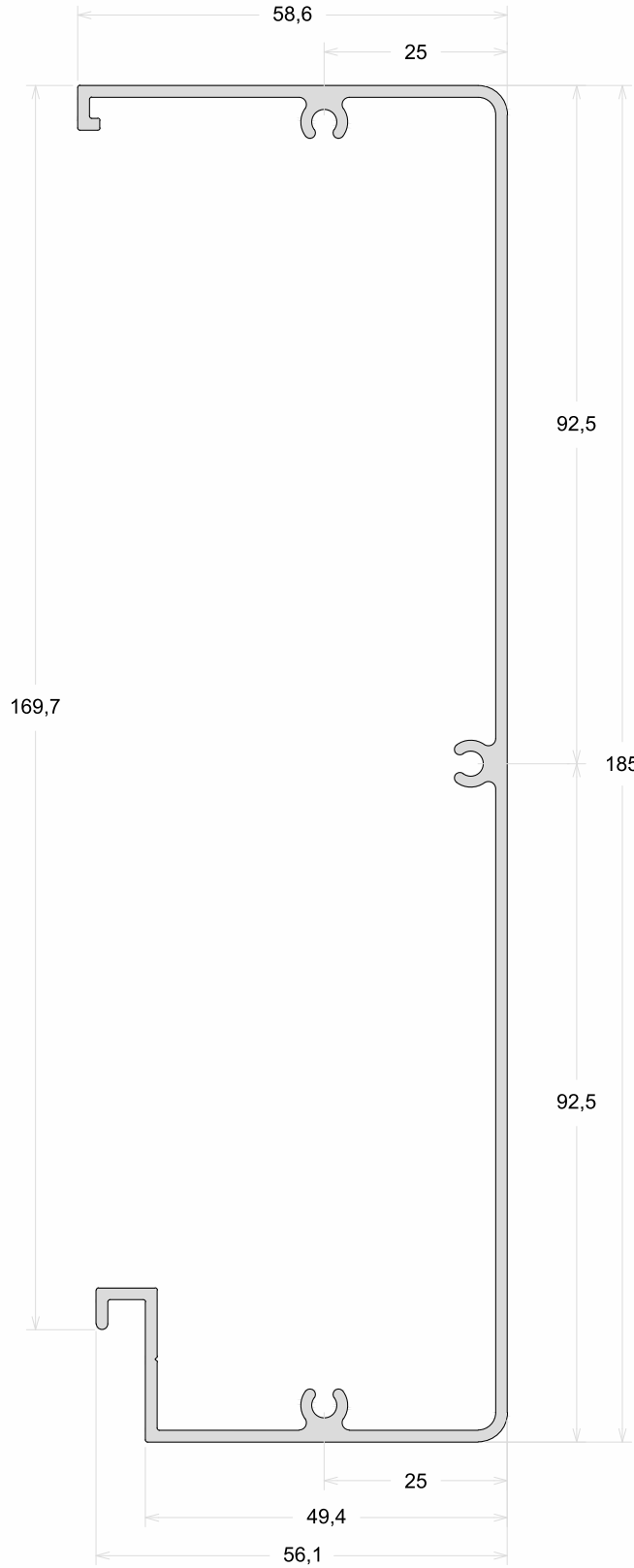

PIT-023	Tampa Interna
Peso (Kg/m)	Perfis De Encaixe:
0,878	

PIT-024	Tampa Interna
Peso (Kg/m)	Perfis De Encaixe:
1,181	

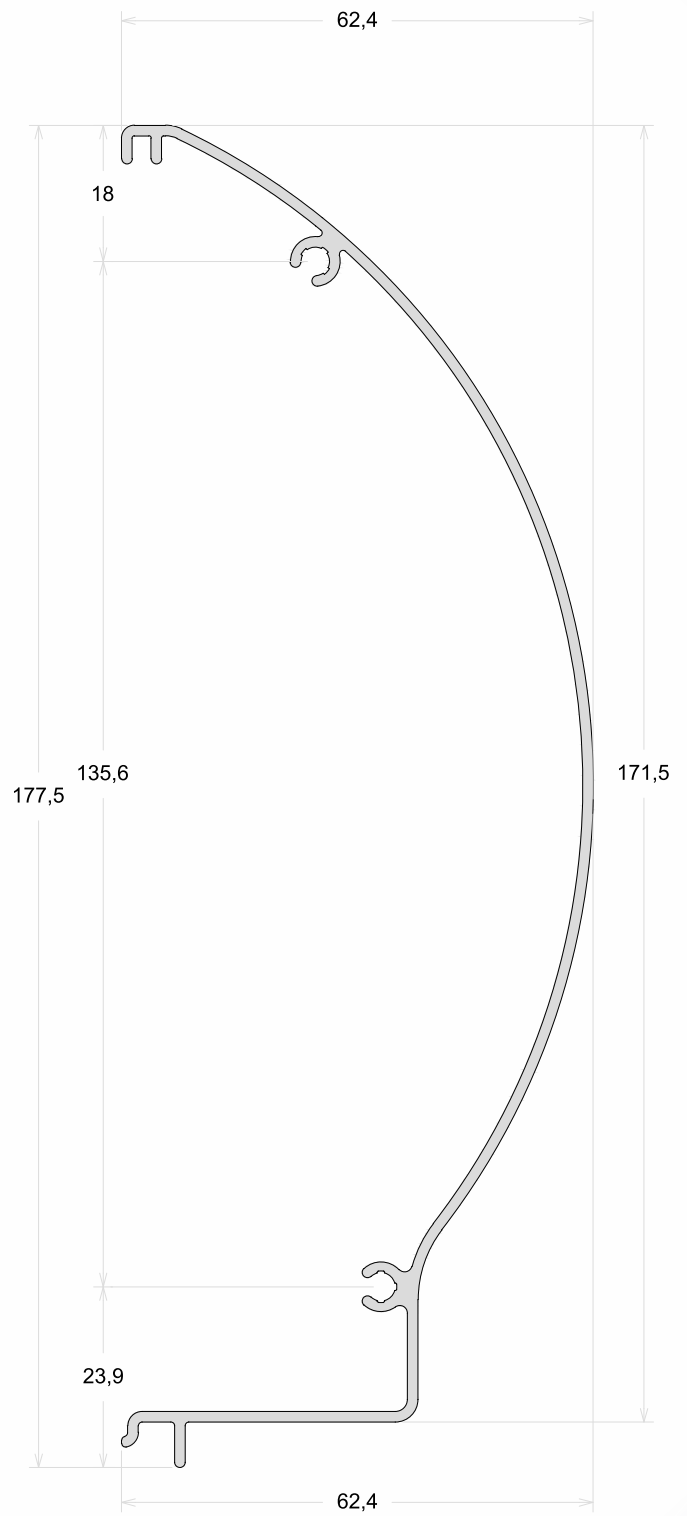
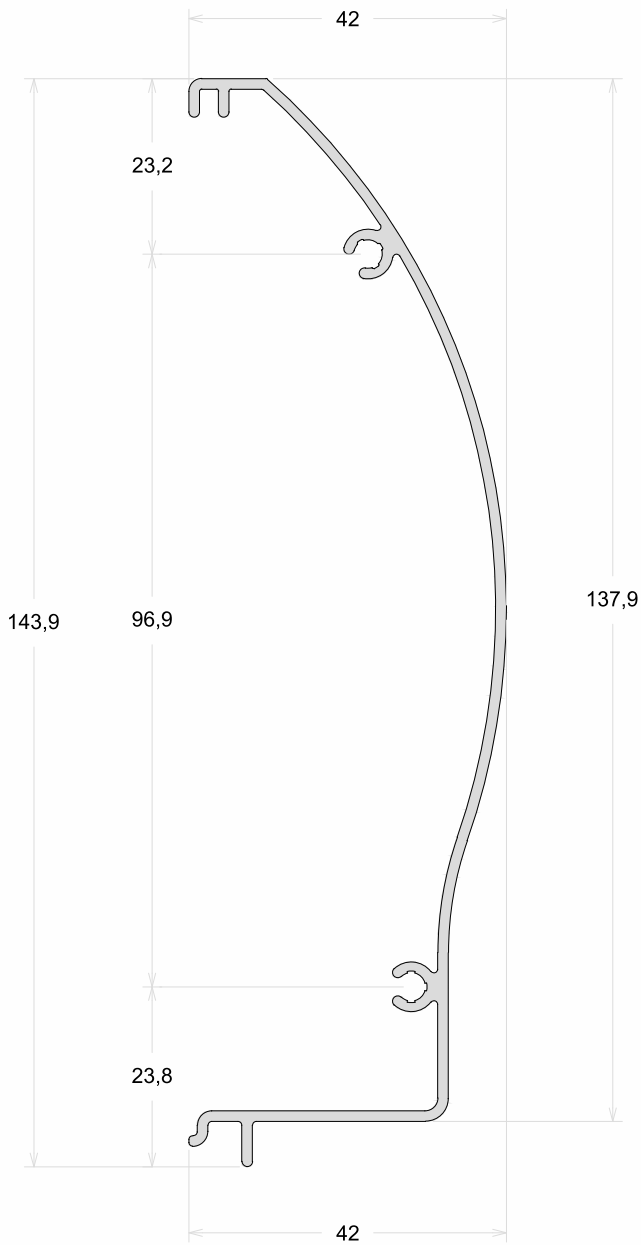

PIT-116	Guia Da Persiana
Peso (Kg/m)	Perfis De Encaixe:
0,697	

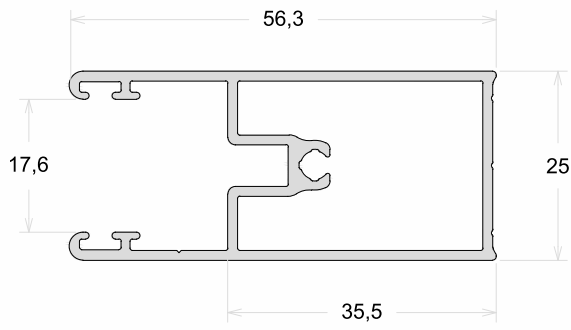

PMN-007	Guia Da Persiana
Peso (Kg/m)	Perfis De Encaixe:
0,660	

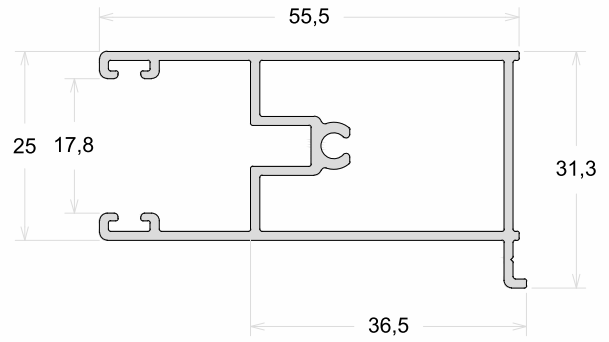

PIT-117	Guia Duplo Da Persiana
Peso (Kg/m)	Perfis De Encaixe:
1,006	

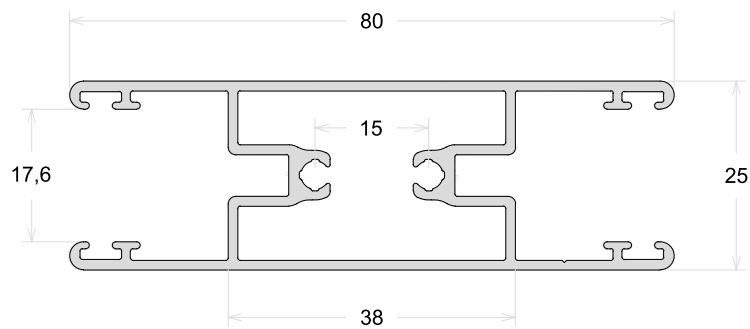

PIT-011	Tubo Reolhedor 40mm
Peso (Kg/m)	Perfis De Encaixe:
0,475	

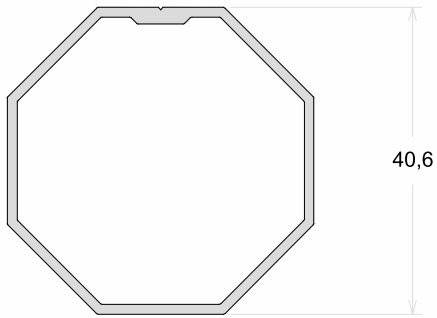

PIT-008	Tubo Reolhedor 60mm
Peso (Kg/m)	Perfis De Encaixe:
0,884	

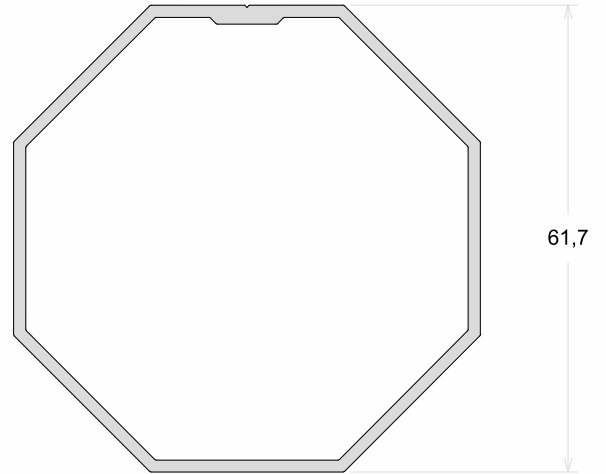

PIT-009	Terminal Da Persiana
Peso (Kg/m)	Perfis De Encaixe:
0,411	

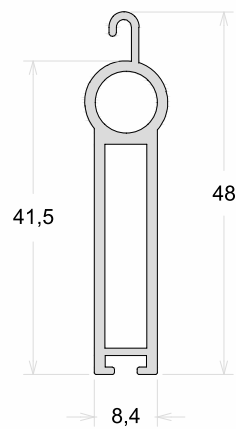

PLG-068	Marco Maxim Ar
Peso (Kg/m)	Perfis De Encaixe: PLG-077
0,369	

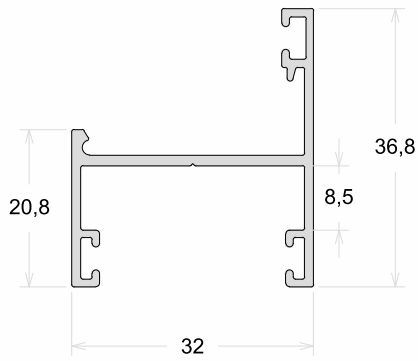

PLG-083	Marco Fixo
Peso (Kg/m)	Perfis De Encaixe: PLG-082 / PLG-026 BG-057 / PLG-059 / PLG-164 PLG-027 / PLG-015
0,368	

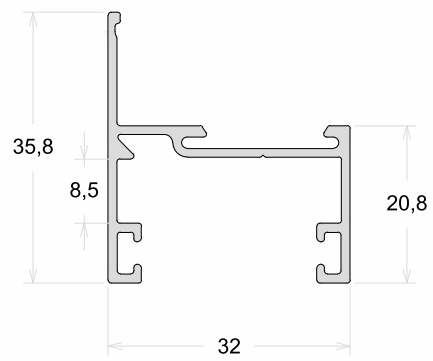

PLG-074	Coluna Maxim Ar
Peso (Kg/m)	Perfis De Encaixe: PLG-077
0,761	

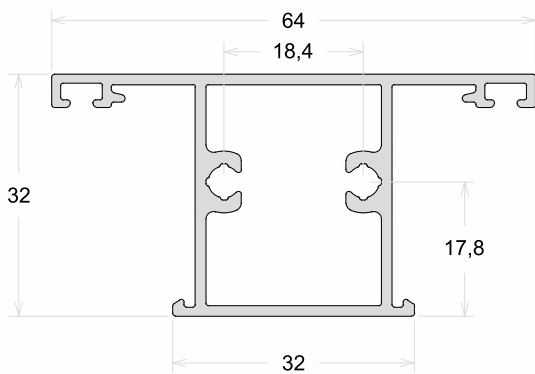

PLG-076	Coluna / Travessa
Peso (Kg/m)	Perfis De Encaixe: PLG-082 / PLG-026 BG-057 / PLG-059 / PLG-164 PLG-027 / PLG-015 / PLG-077
0,679	

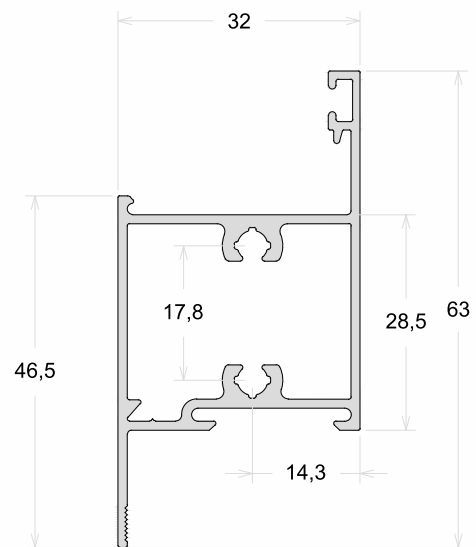

PLG-079	Travessa 62mm
Peso (Kg/m)	Perfis De Encaixe: PLG-082 / PLG-026
0,696	BG-057 / PLG-059 / PLG-164 PLG-027 / PLG-015

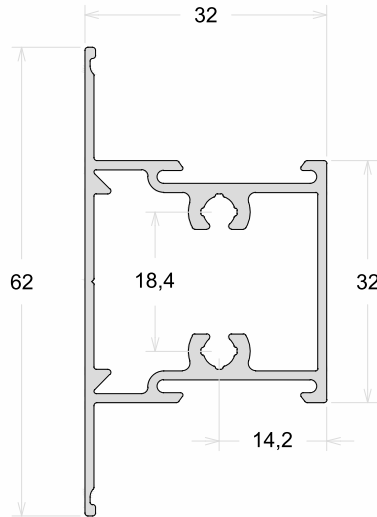

PLG-077	Inversor De Baguetes
Peso (Kg/m)	Perfis De Encaixe: PLG-068 / PLG-026
0,300	BG-057 / PLG-059 / PLG-164 PLG-027 / PLG-015 / PLG-076

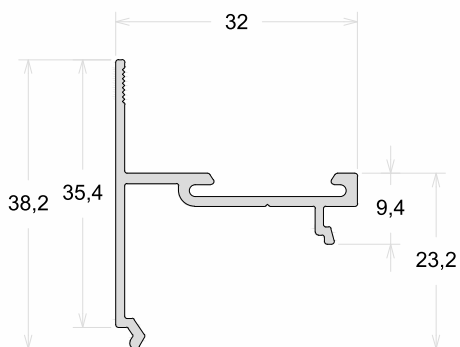

PLG-082	Inversor Maxim Ar
Peso (Kg/m)	Perfis De Encaixe: PLG-083 / PLG-079
0,318	

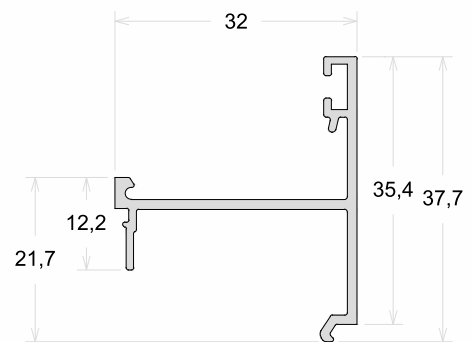

PLG-091 Pingadeira Maxim Ar

Peso (Kg/m): 0,135

Perfis De Encaixe: PLG-068

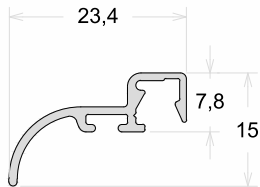

PLG-092 Pingadeira Auxiliar

Peso (Kg/m): 0,145

Perfis De Encaixe:

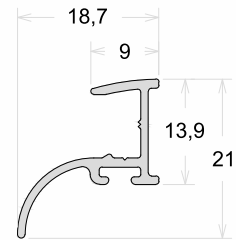

PLG-071 Folha Maxim Ar

Peso (Kg/m): 0,362

Perfis De Encaixe: BG-057 / PLG-026 / PLG-059 / PLG-164 / PLG-027 / PLG-015

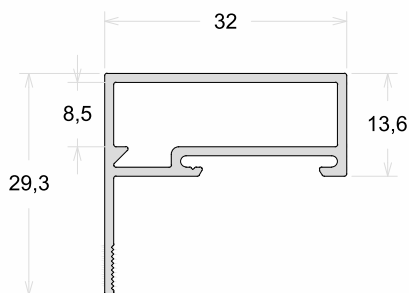

PLG-085 Folha Maxim Ar

Peso (Kg/m): 0,452

Perfis De Encaixe: BG-057 / PLG-026 / PLG-059 / PLG-164 / PLG-027 / PLG-015

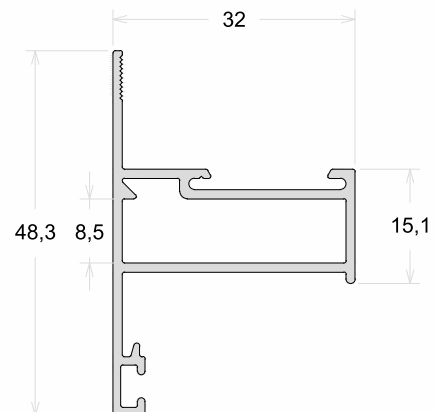

PLG-056	Marco Porta De Giro
Peso (Kg/m)	Perfis De Encaixe:
0,588	

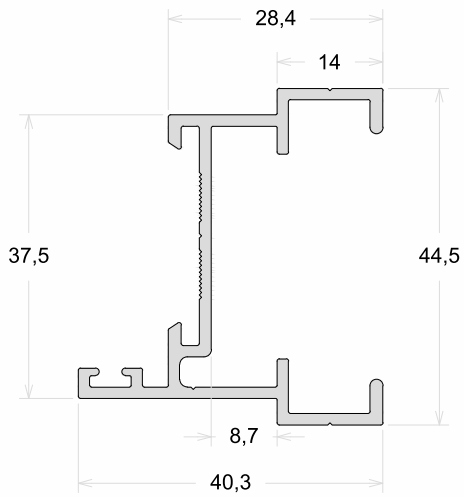

PLG-016	Batente Porta De Giro
Peso (Kg/m)	Perfis De Encaixe:
0,316	

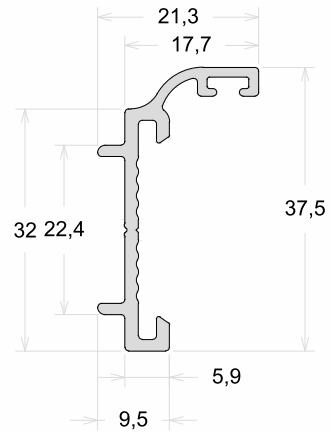

PLG-043	Folha Porta De Giro
Peso (Kg/m)	Perfis De Encaixe:
0,877	BG-057 / PLG-026 / PLG-059 PLG-164 / PLG-027 / PLG-015

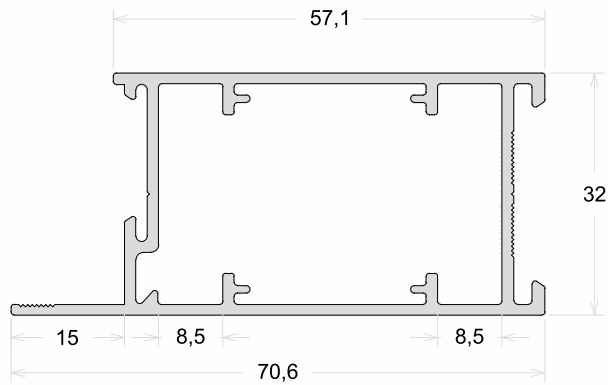

PLG-042	Folha Porta de Giro
Peso (Kg/m)	Perfis De Encaixe:
1,104	

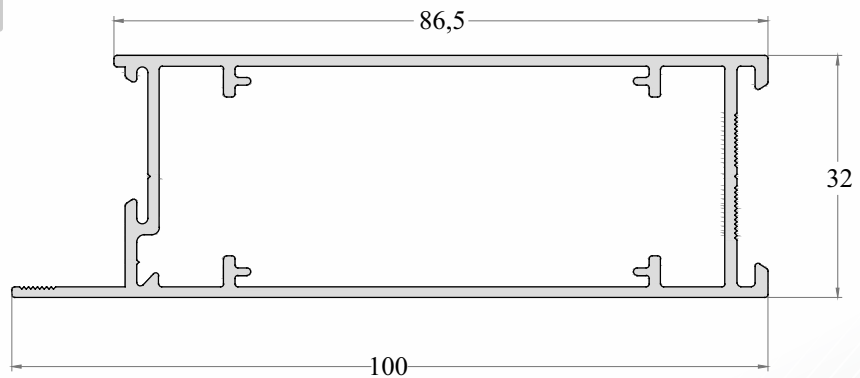

PLG-239	Folha Porta De Giro Lambri
Peso (Kg/m)	Perfis De Encaixe: PLG-238
1,121	

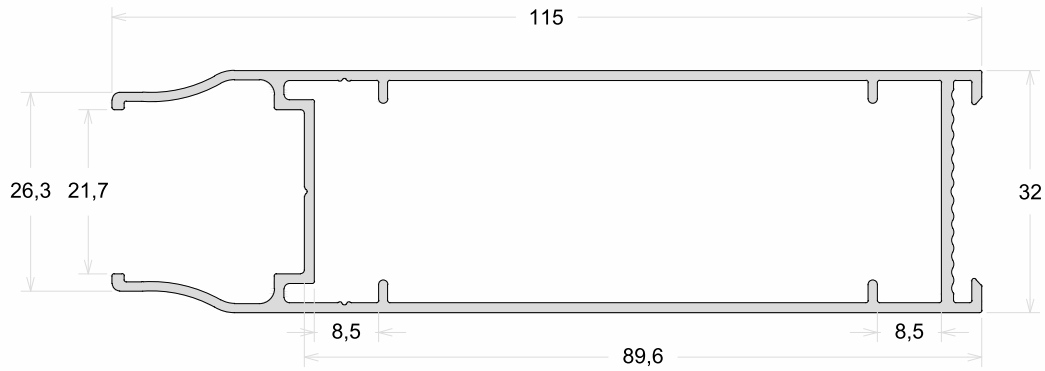

PLG-238	Redutor Para PLG-239
Peso (Kg/m)	Perfis De Encaixe: PLG-239
0,273	

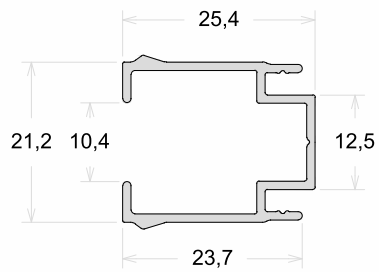

DV-013	Acabamento Ripado Duplo
Peso (Kg/m)	Perfis De Encaixe: PLG-239 / PLG-043
0,318	

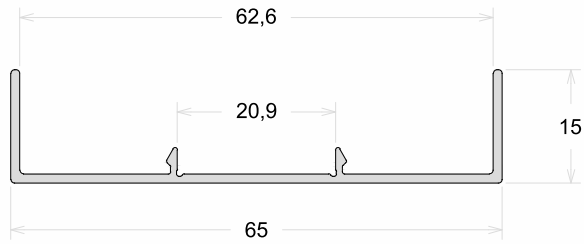

DV-014	Acabamento Ripado Duplo Pivotante
Peso (Kg/m)	Perfis De Encaixe: PLG-239 / PLG-043
0,342	

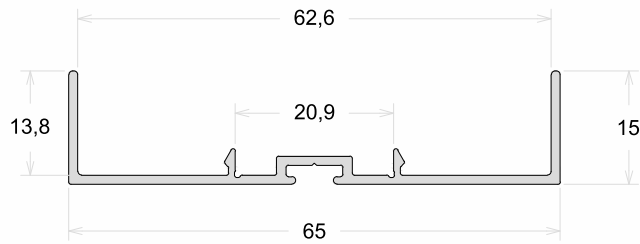

DV-015	Acabamento Ripado Duplo
Peso (Kg/m)	Perfis De Encaixe: PLG-239 / PLG-043
0,367	

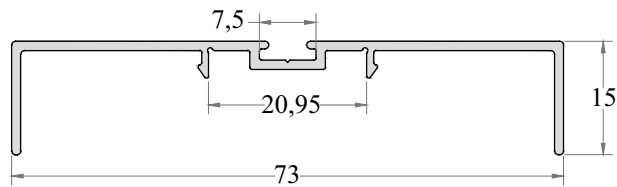

BG-057 Baguete Horizontal e Vertical

Peso (Kg/m) 0,168

Perfis De Encaixe:

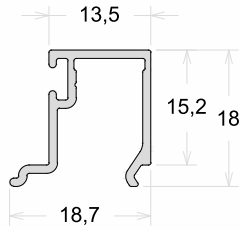

PLG-026 Baguete Vertical

Peso (Kg/m) 0,159

Perfis De Encaixe:

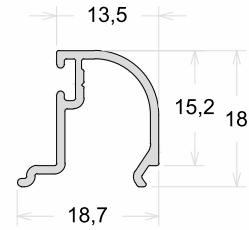

PLG-059 Baguete Vertical e Horizontal

Peso (Kg/m) 0,157

Perfis De Encaixe:

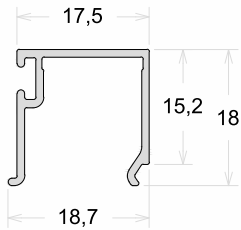

PLG-164 Baguete Vertical

Peso (Kg/m) 0,148

Perfis De Encaixe:

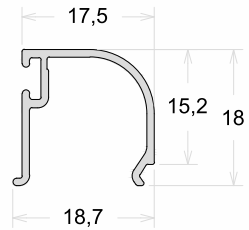

PLG-015 Baguete Vidro Duplo

Peso (Kg/m) 0,114

Perfis De Encaixe:

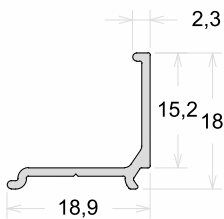

PLG-027 Baguete Veneziana

Peso (Kg/m) 0,146

Perfis De Encaixe:

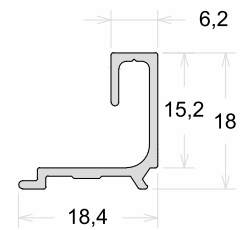

PPO-008	Marco Regulável
Peso (Kg/m)	Perfis De Encaixe: PPO-010 / PPO-011 / PPO-012 / PPO-013
1,031	

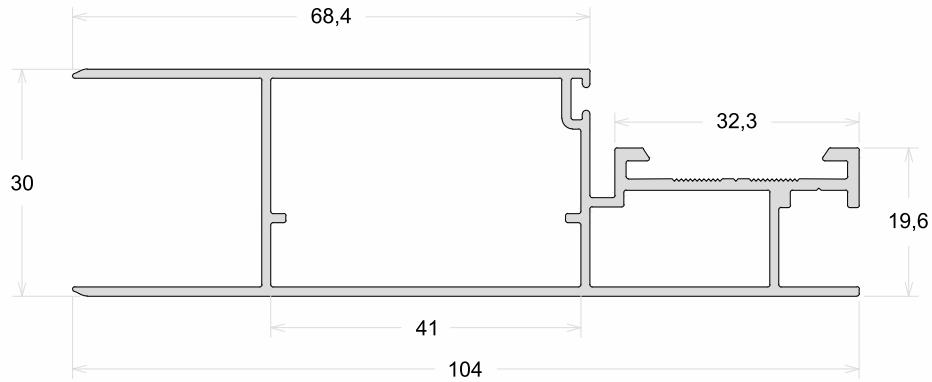

PPO-013	Click Da Folha e Do Marco
Peso (Kg/m)	Perfis De Encaixe: PSU-350 / PSU-111 / PPO-008
0,079	

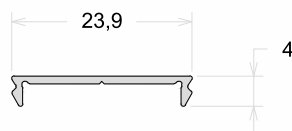

PLG-181	Marco Superior
Peso (Kg/m)	Perfis De Encaixe:
1,098	

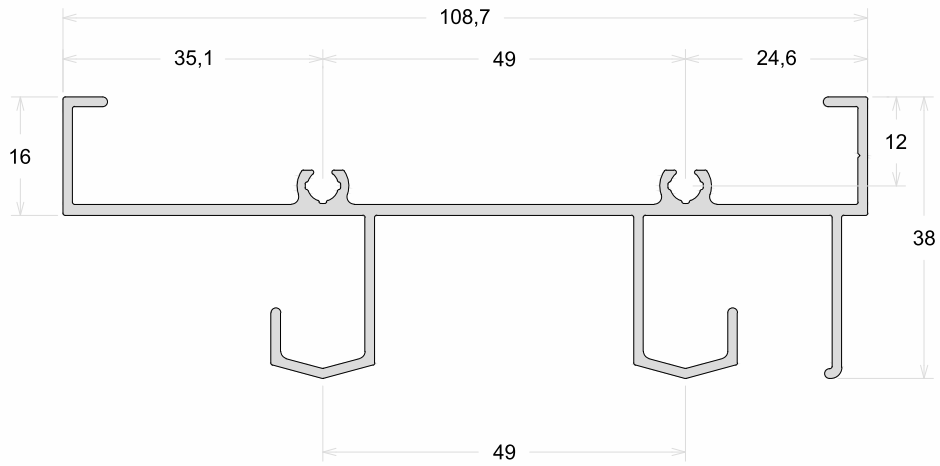

PLG-180	Marco Inferior
Peso (Kg/m)	Perfis De Encaixe:
1,662	

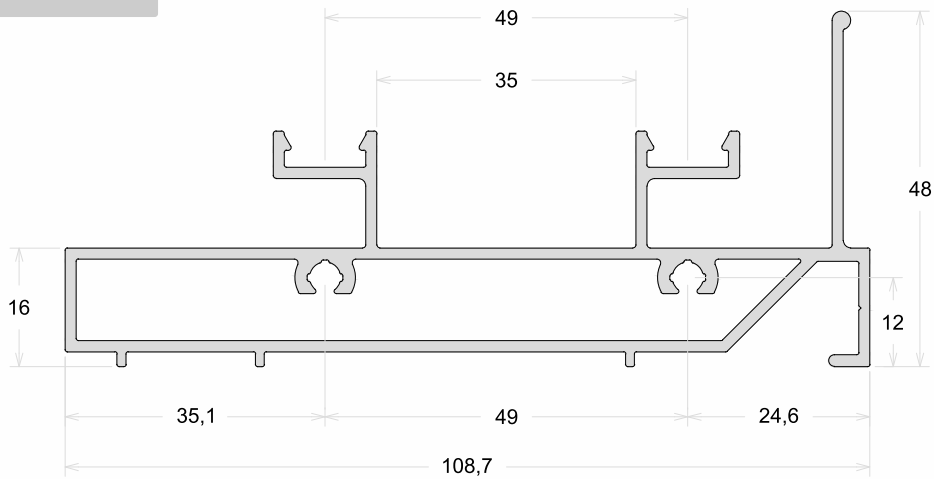

PLG-187	Marco Lateral
Peso (Kg/m)	Perfis De Encaixe:
0,600	

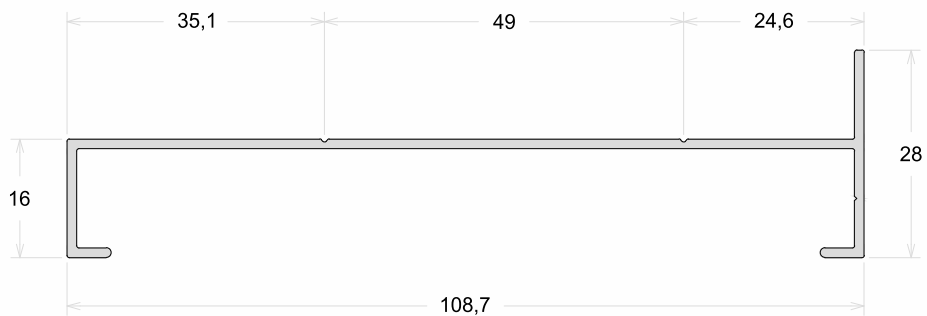

PLG-196	Trilho Superior Três Planos
Peso (Kg/m)	Perfis De Encaixe:
1,601	

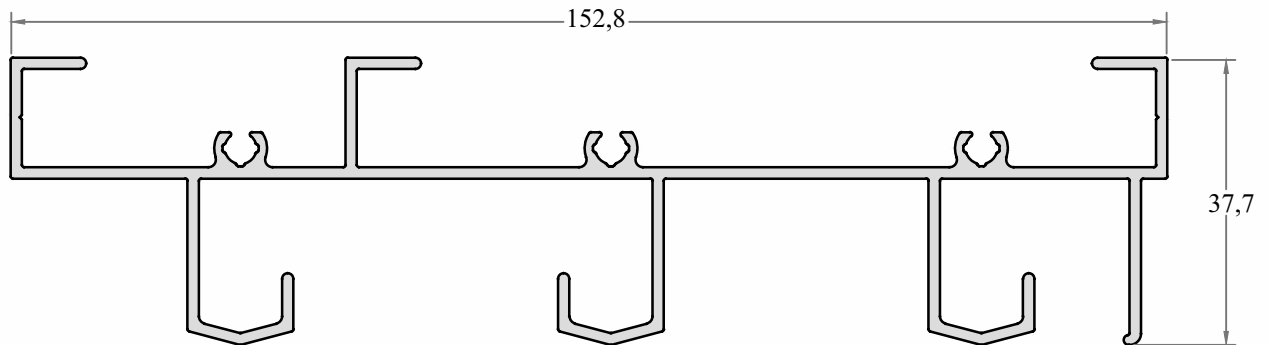

PLG-197	Trilho Inferior Três Planos
Peso (Kg/m)	Perfis De Encaixe:
2,105	

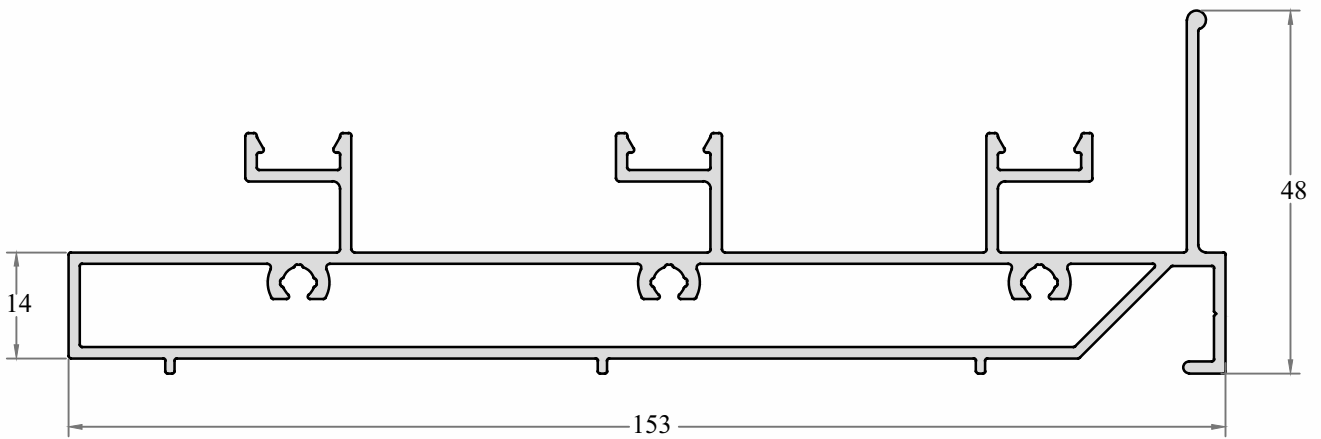

PLG-198	Marco Lateral Três Planos
Peso (Kg/m)	Perfis De Encaixe:
0,940	

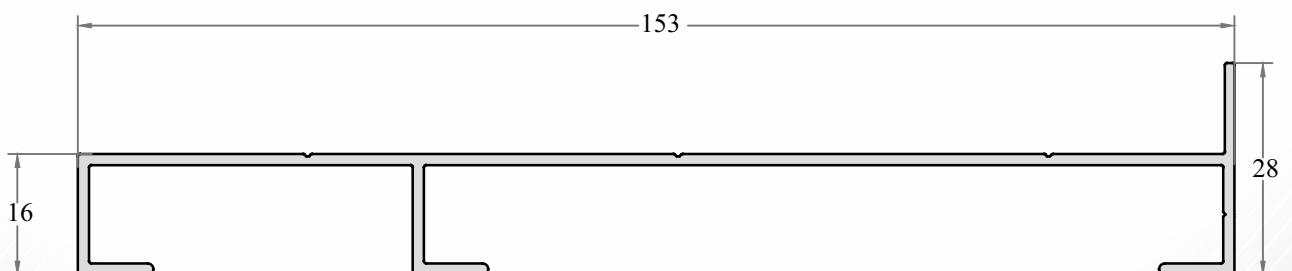

PLG-188	Mata Junta Central e Lateral
Peso (Kg/m)	Perfis De Encaixe:
0,416	

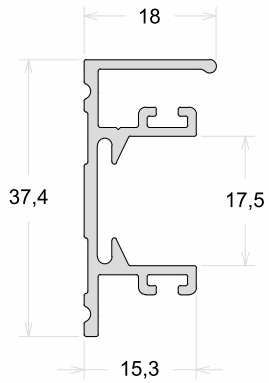

PLG-193	Pingadeira Externa
Peso (Kg/m)	Perfis De Encaixe:
0,168	

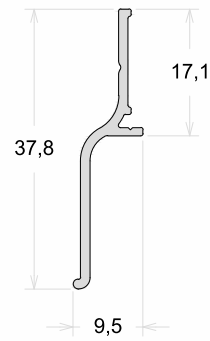

PLG-111	Click do Trilho
Peso (Kg/m)	Perfis De Encaixe:
0,095	

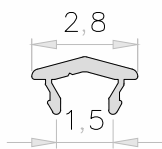

PLG-183	Coluna Central
Peso (Kg/m)	Perfis De Encaixe:
0,755	

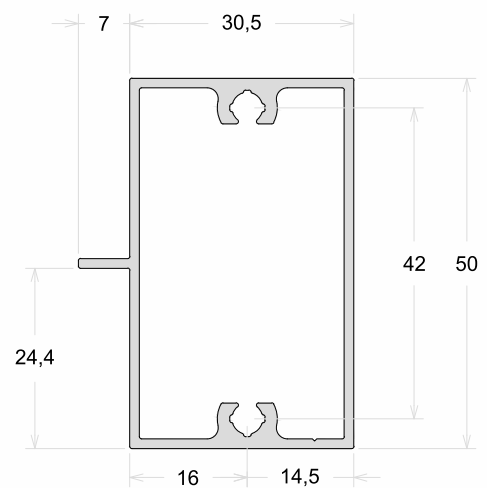

PLG-182	Folha Horizontal
Peso (Kg/m)	Perfis De Encaixe:
0,615	

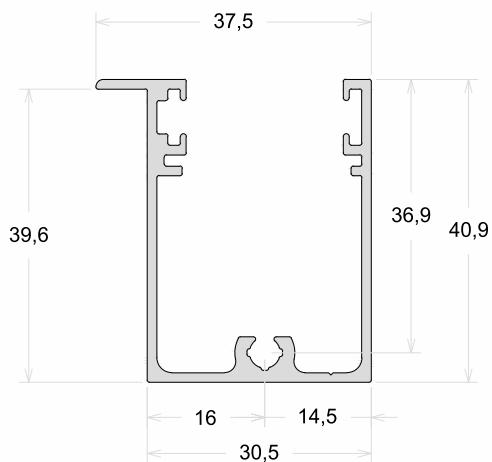

PLG-194	Folha Horizontal
Peso (Kg/m)	Perfis De Encaixe:
0,571	

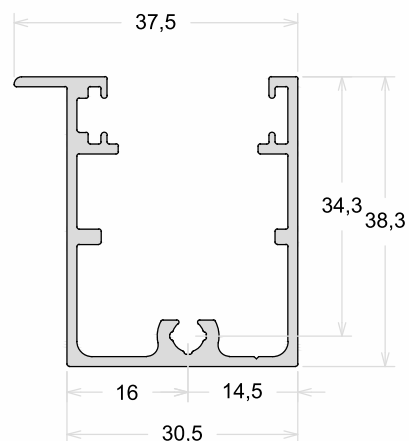

PLG-189	Folha Horizontal Porta
Peso (Kg/m)	Perfis De Encaixe:
1,206	

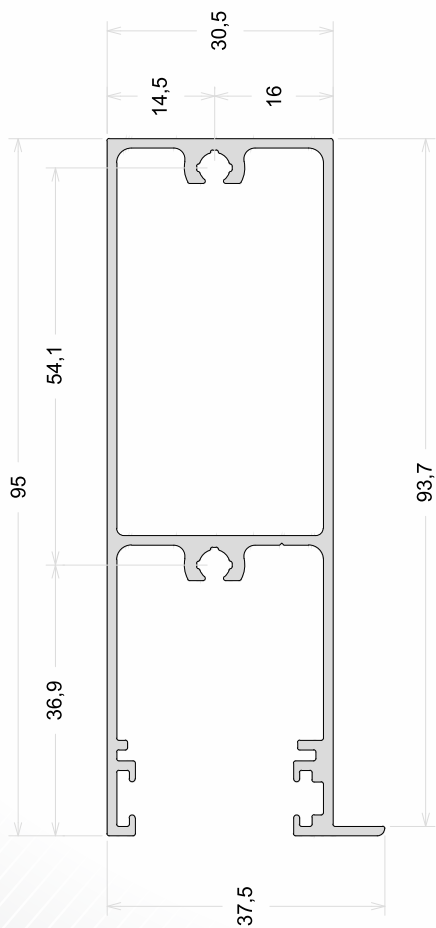

PLG-195	Folha Horizontal
Peso (Kg/m)	Perfis De Encaixe:
1,050	

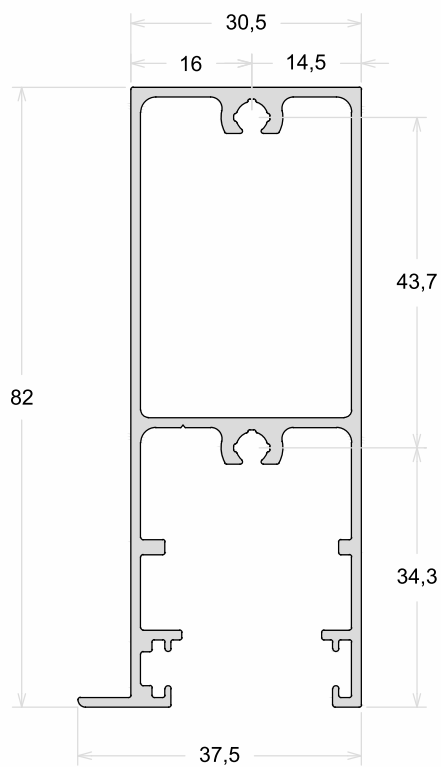

PLG-185	Folha Lateral
Peso (Kg/m)	Perfis De Encaixe:
0,697	

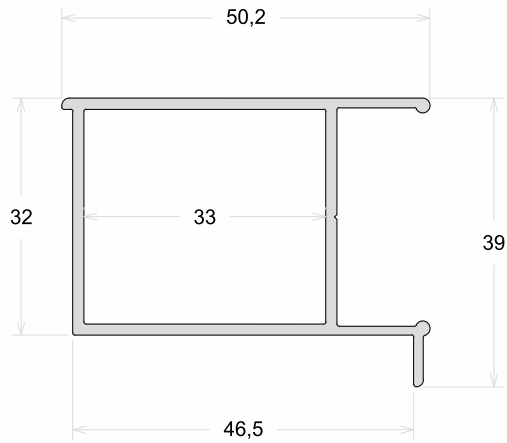

PLG-192	Folha Lateral Com Reforço
Peso (Kg/m)	Perfis De Encaixe:
0,897	

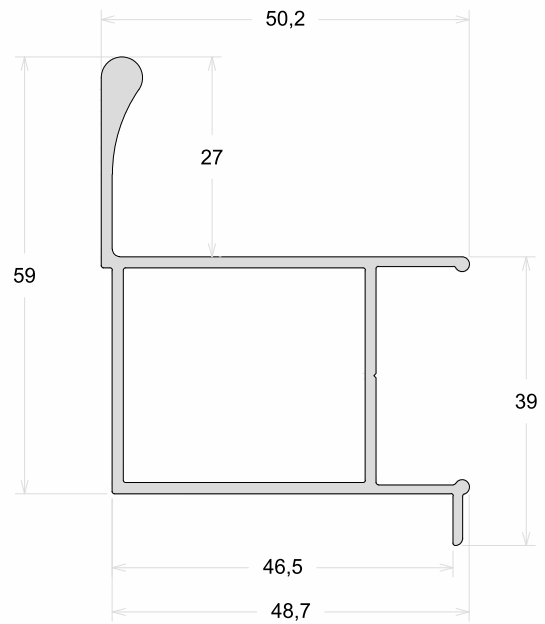

PLG-184	Mão De Amigo Interno
Peso (Kg/m)	Perfis De Encaixe:
0,639	

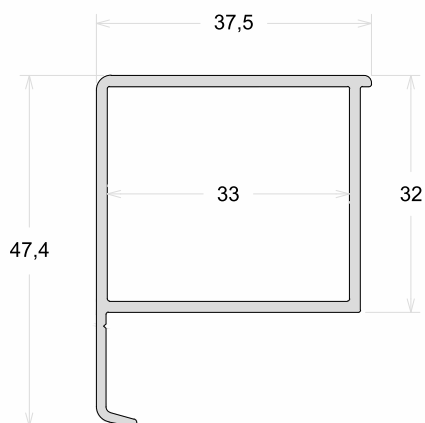

PLG-191	Mão De Amigo Externo
Peso (Kg/m)	Perfis De Encaixe:
0,759	

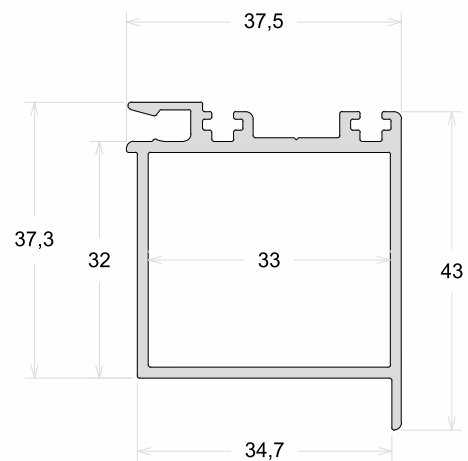

PLG-190	Mão De Amigo Interno Com Reforço
Peso (Kg/m)	Perfis De Encaixe:
1,191	

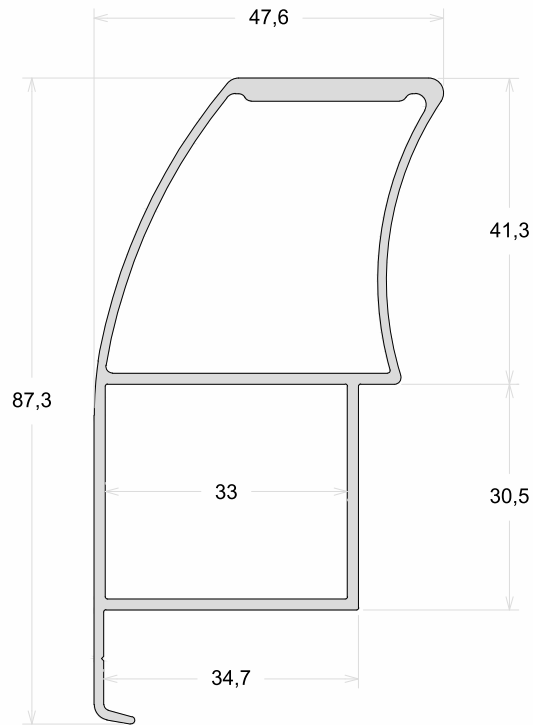

PLG-186	Mão De Amigo Externo Com Reforço
Peso (Kg/m)	Perfis De Encaixe:
0,923	

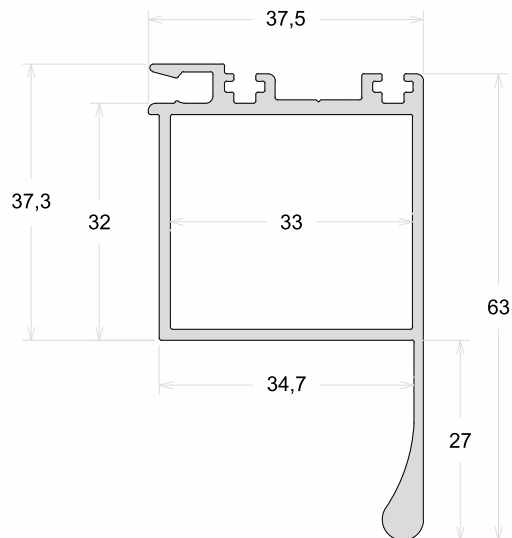

FX-204	Coluna Central 38mm
Peso (Kg/m)	Perfis De Encaixe:
1,038	

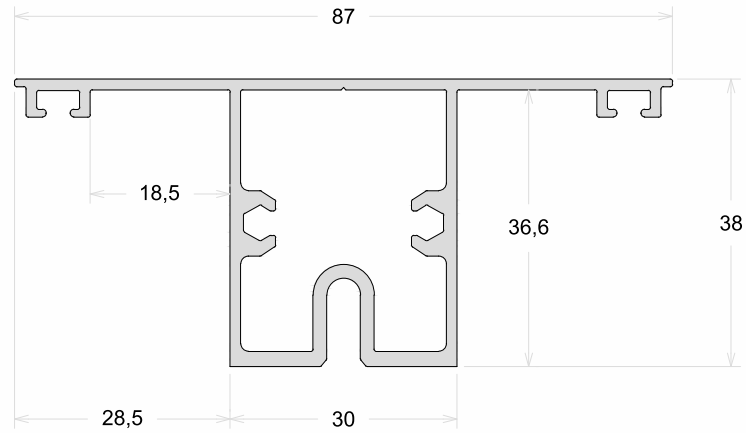

FX-400	Coluna Central 70mm
Peso (Kg/m)	Perfis De Encaixe:
1,433	

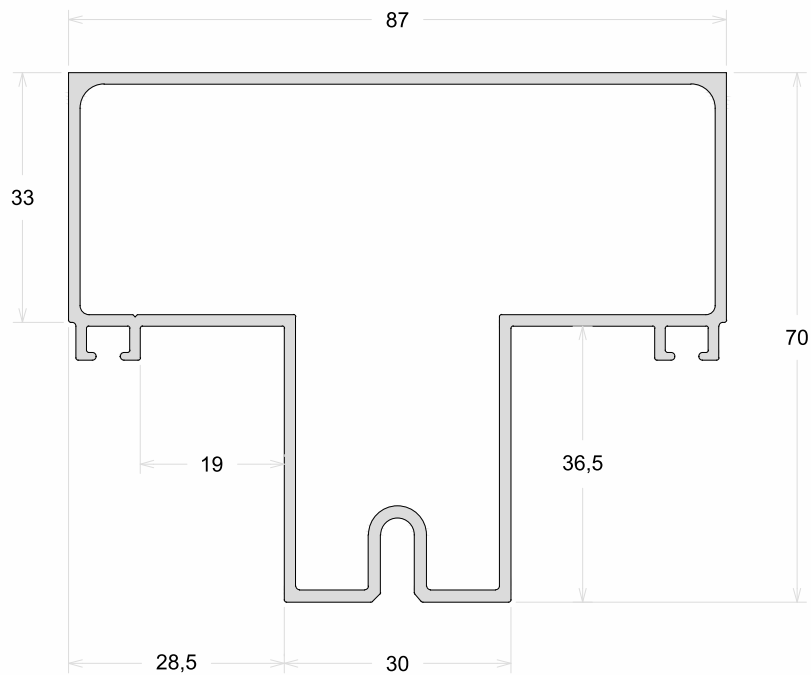

FX-264	Luva para 1/2 Coluna
Peso (Kg/m)	Perfis De Encaixe:
1,188	

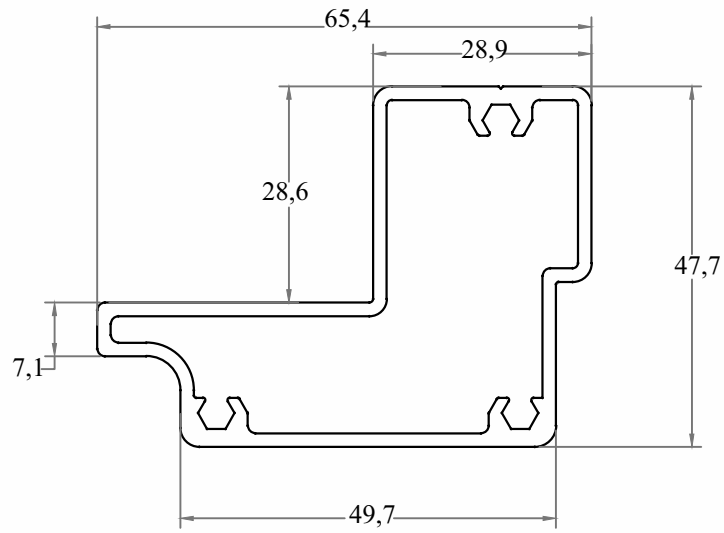

FX-347	1/2 Coluna
Peso (Kg/m)	Perfis De Encaixe:
1,242	

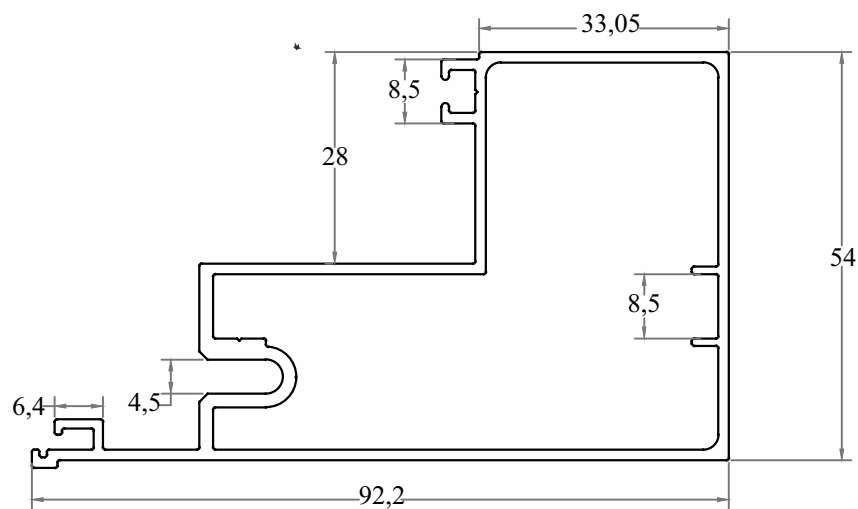

FX-200	Coluna Central 92mm
Peso (Kg/m)	Perfis De Encaixe:
1,825	

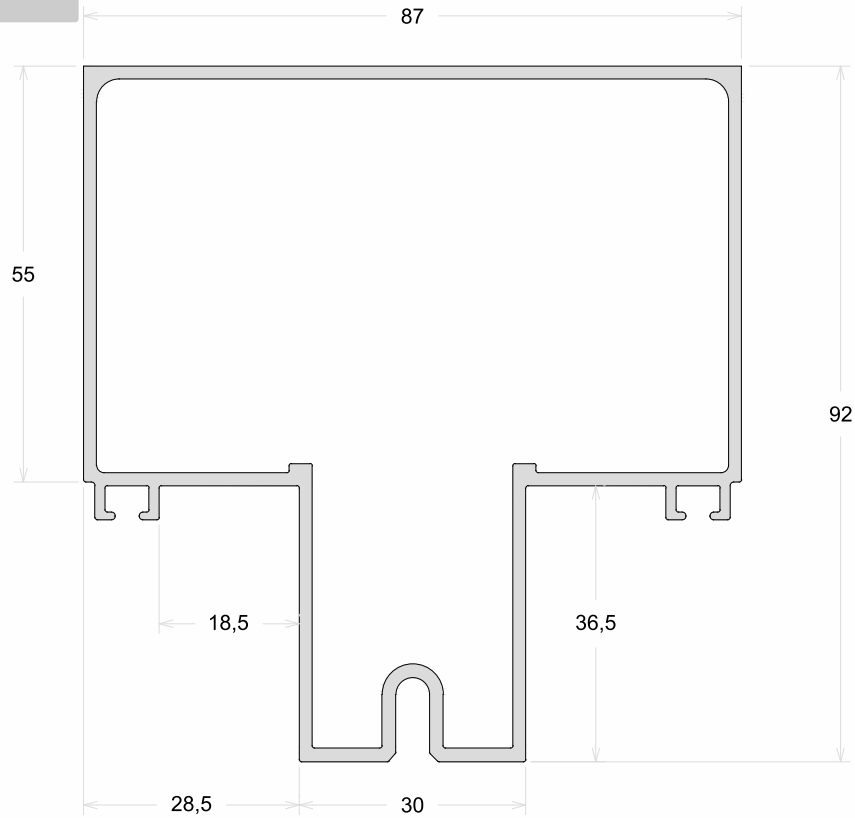

FX-223	Luva Da Coluna Central 92mm
Peso (Kg/m)	Perfis De Encaixe:
2,081	

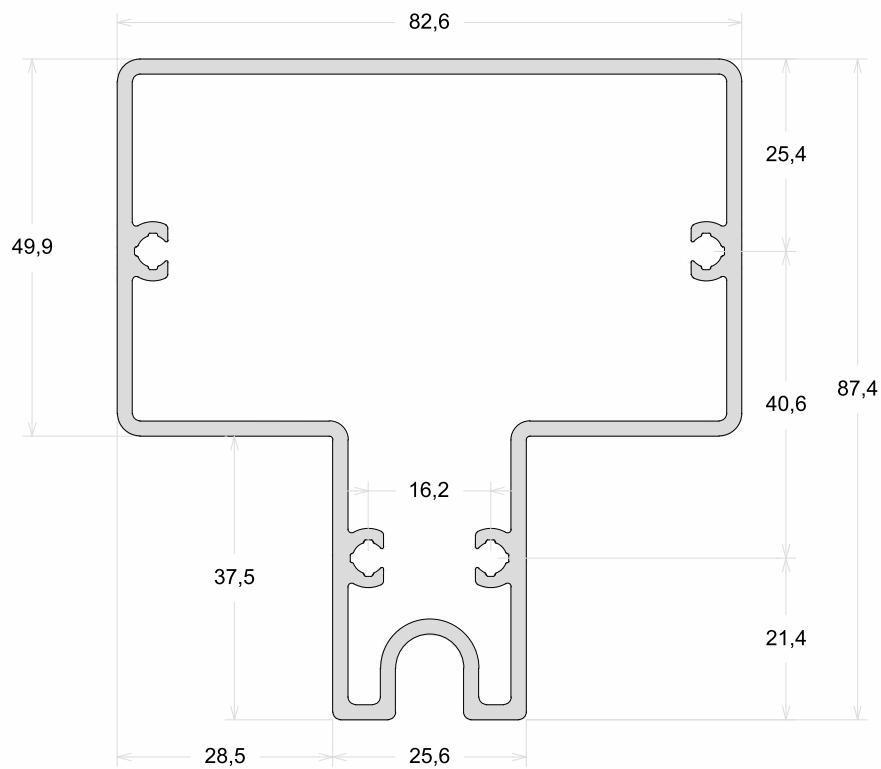

FX-375	Coluna Central 120mm
Peso (Kg/m)	Perfis De Encaixe:
2,463	

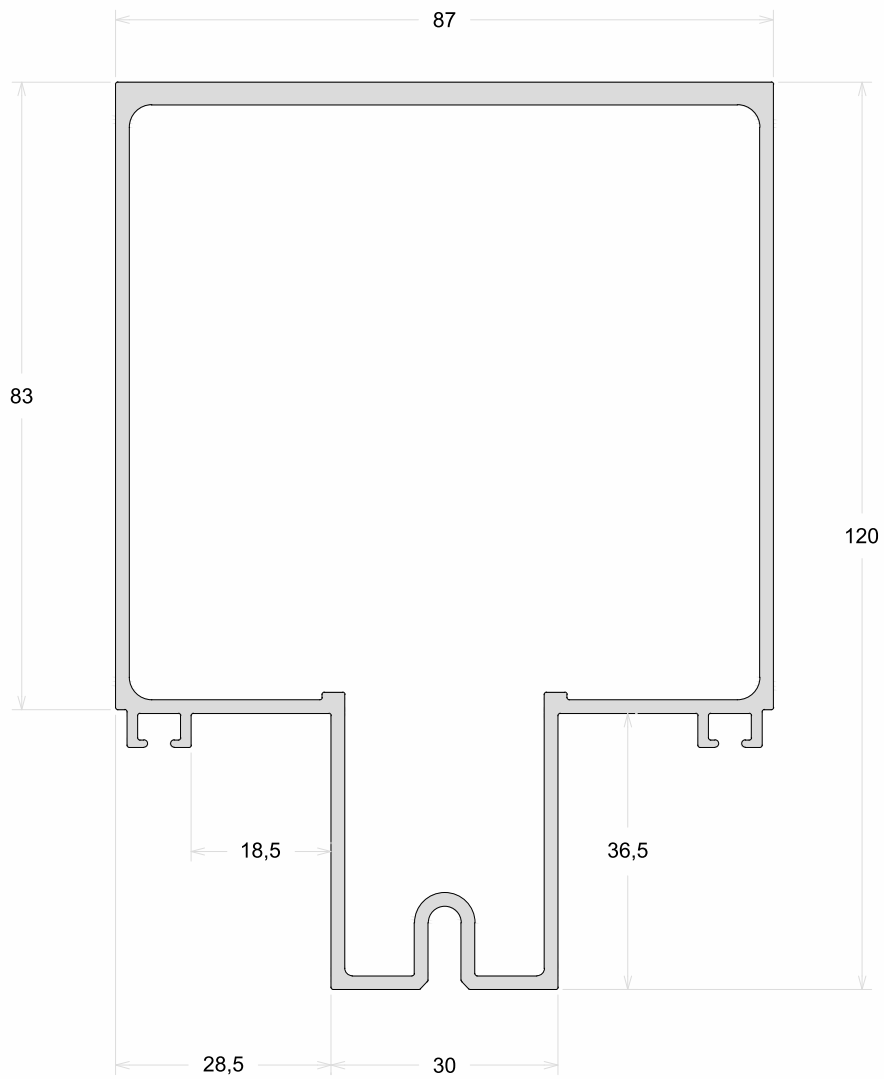

FX-376	Luva Da Coluna Central 120mm
Peso (Kg/m)	Perfis De Encaixe:
2,295	

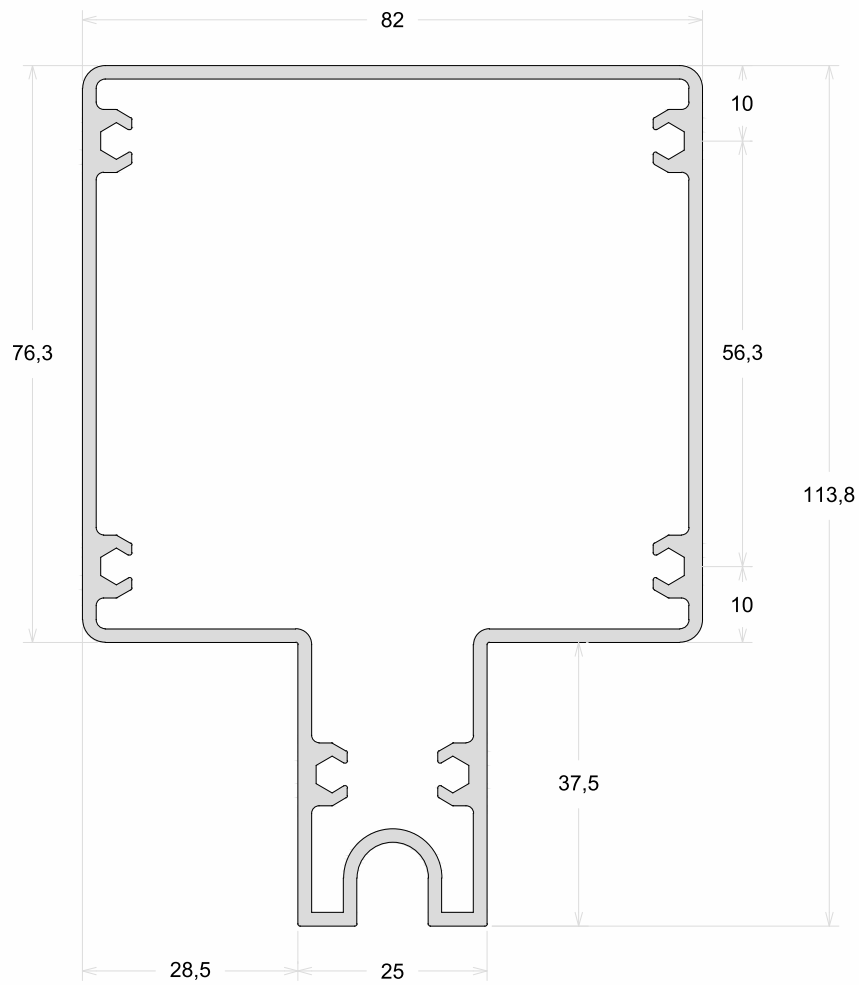

FX-236	Coluna Canto 90°
Peso (Kg/m)	Perfis De Encaixe:
2,343	

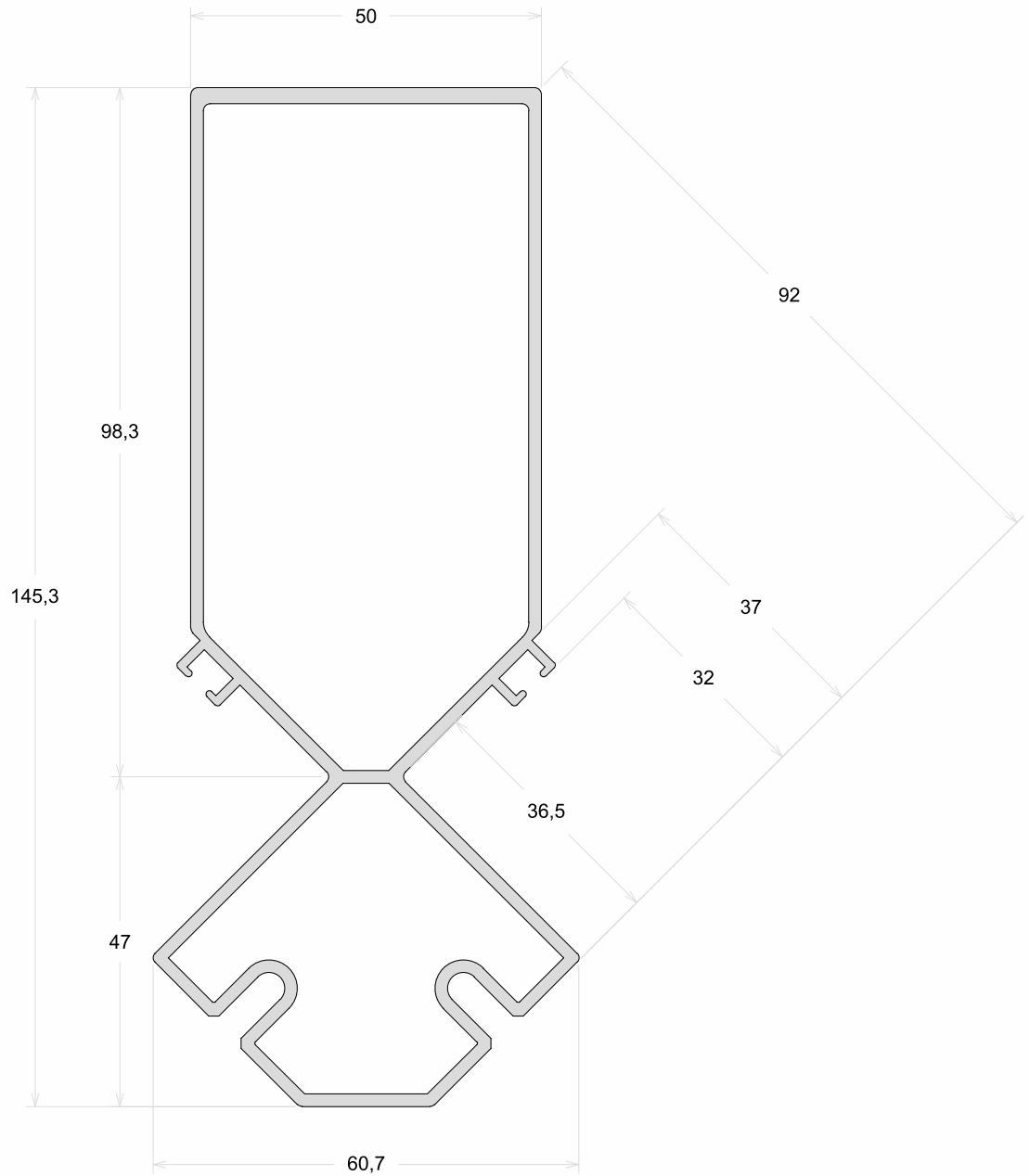

FX-233	Travessa
Peso (Kg/m)	Perfis De Encaixe:
0,886	FX-226 / FX-397 / FX-227

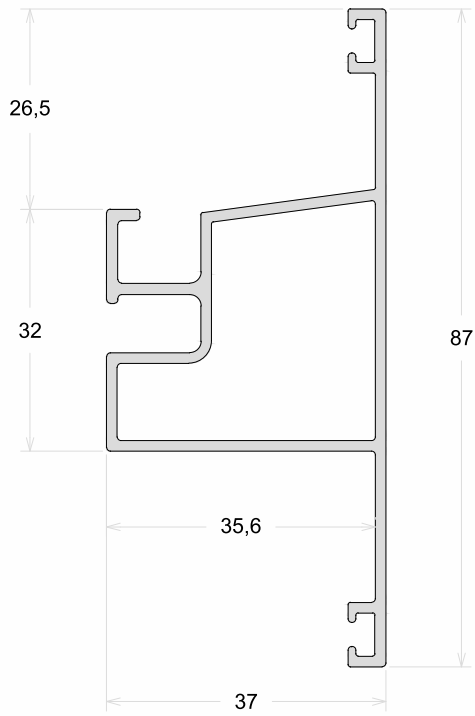

FX-294	Marco Para Coluna 38mm
Peso (Kg/m)	Perfis De Encaixe:
0,774	

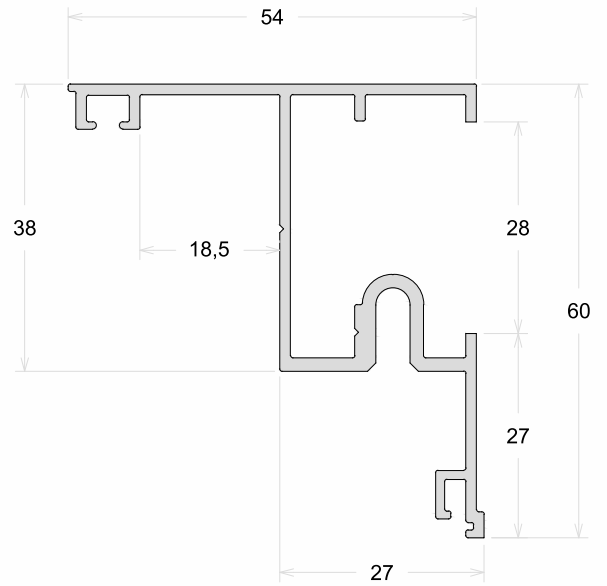

FX-260	Marco Para Coluna 70mm
Peso (Kg/m)	Perfis De Encaixe:
1,178	

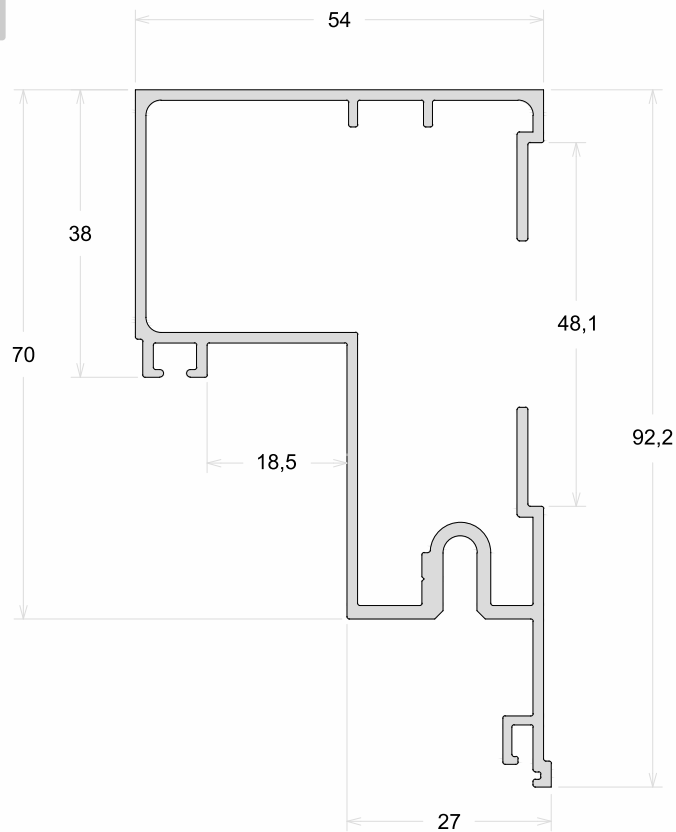

FX-515	Marco Para Coluna 92mm
Peso (Kg/m)	Perfis De Encaixe:
1,484	

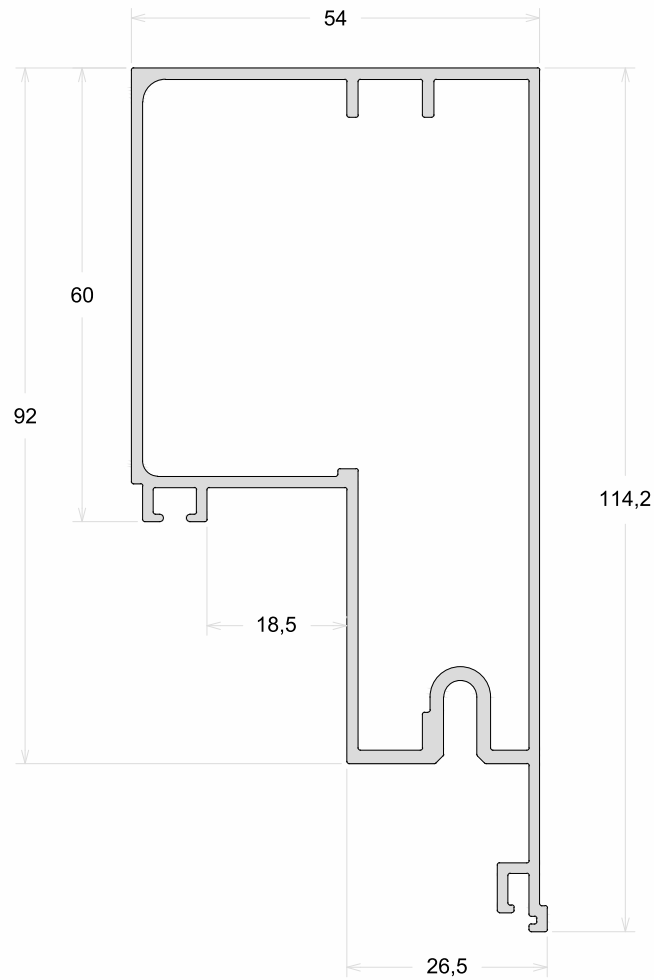

FX-511	Marco Telescópico 92mm
Peso (Kg/m)	Perfis De Encaixe:
1,249	

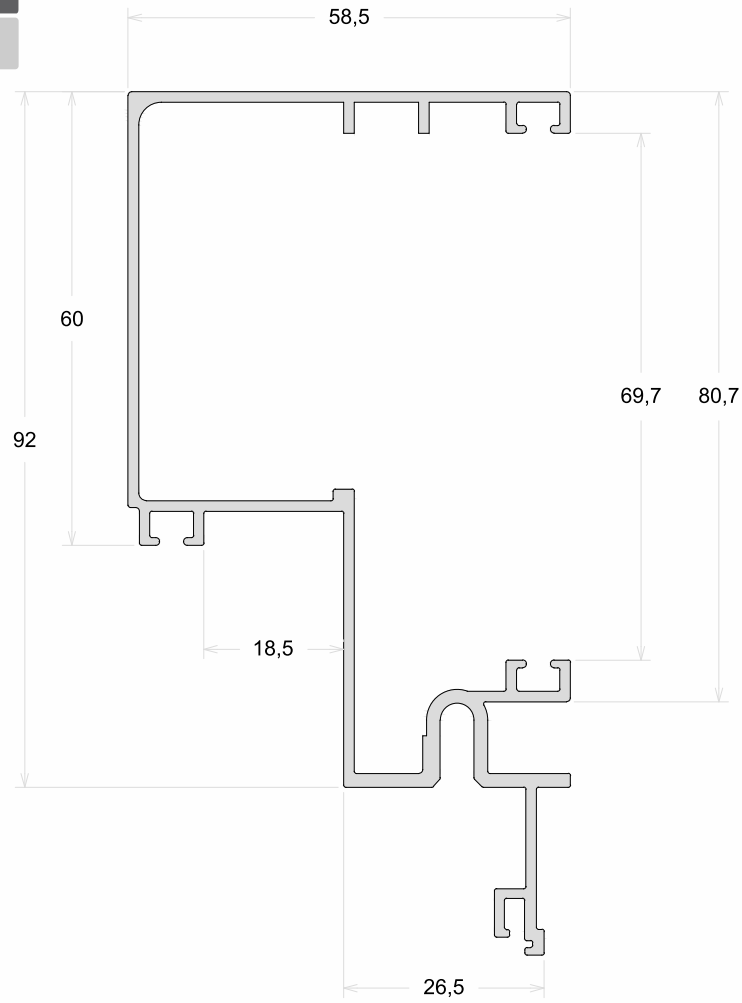

FX-512	Luva Telescópica
Peso (Kg/m)	Perfis De Encaixe:
0,509	

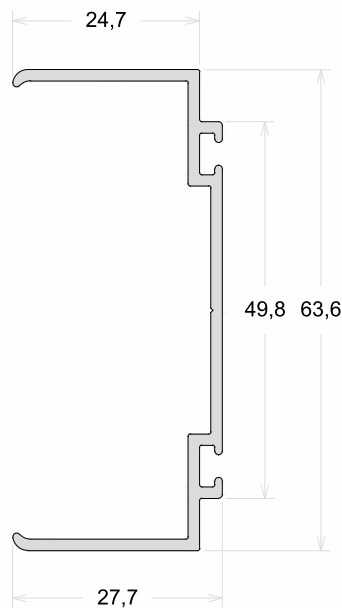

FX-278	Marco Para Coluna 120mm
Peso (Kg/m)	Perfis De Encaixe:
1,452	

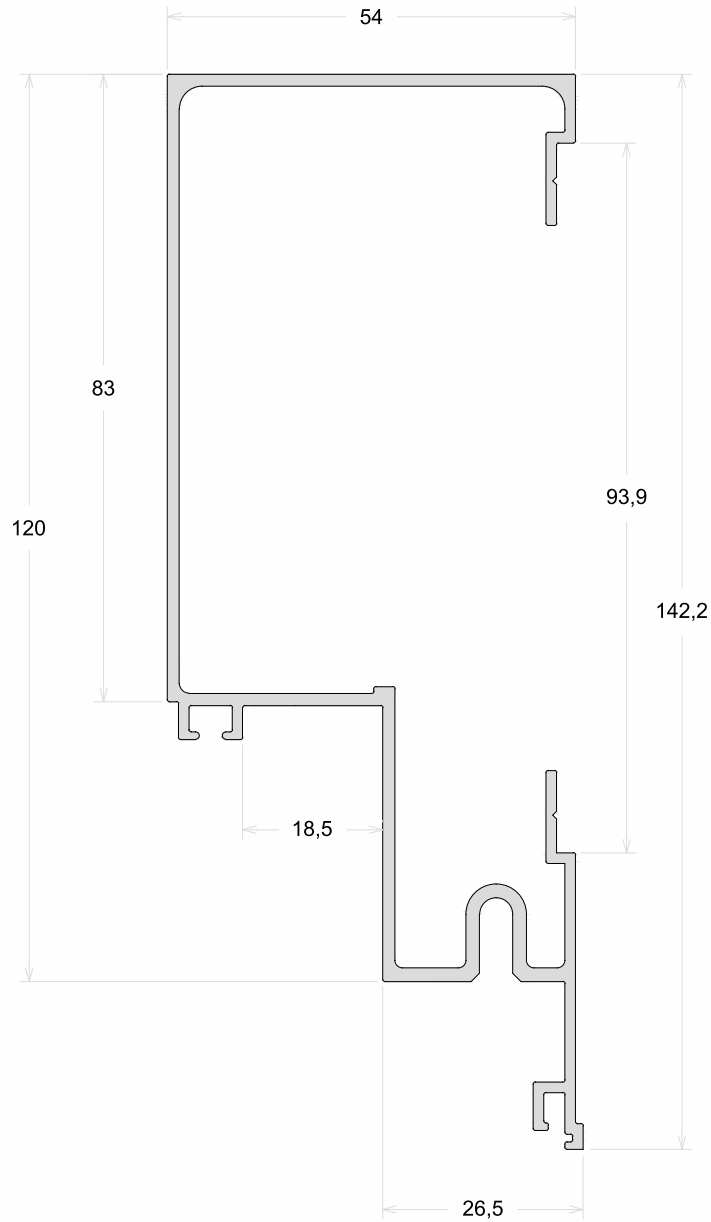

FX-279	Luva Do Marco 120mm
Peso (Kg/m)	Perfis De Encaixe:
1,825	

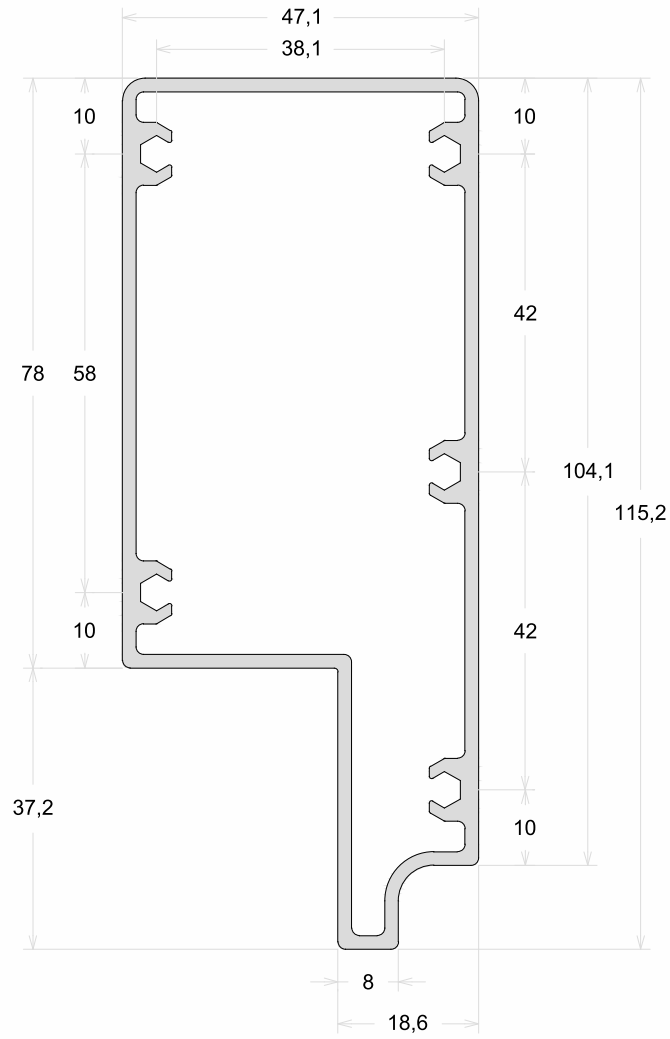

FX-232	Folha Horizontal - Fixo
Peso (Kg/m)	Perfis De Encaixe: FX-247 / FX-227
0,607	

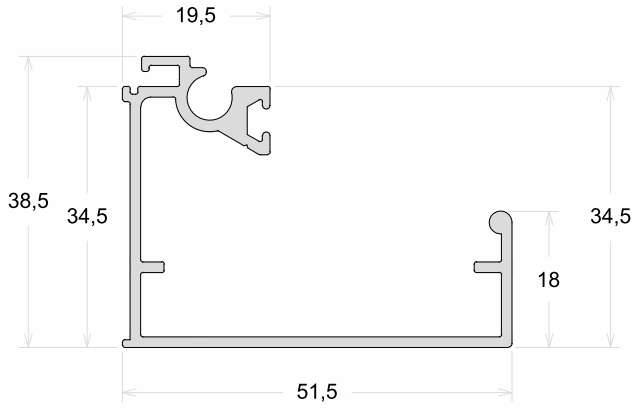

FX-228	Folha Vertical - Fixo
Peso (Kg/m)	Perfis De Encaixe: FX-247
0,572	

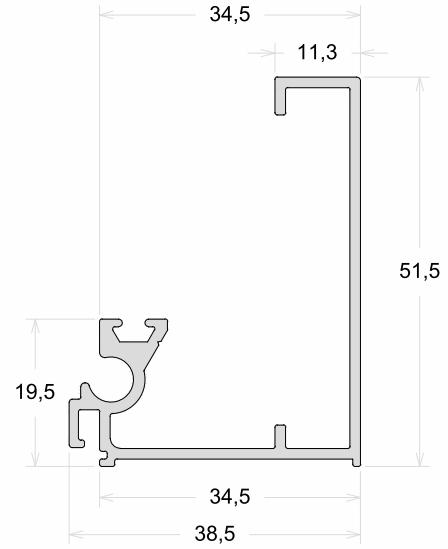

FX-230	Folha Horizontal - Móvel / Fixo
Peso (Kg/m)	Perfis De Encaixe: FX-247 / FX-227
0,813	

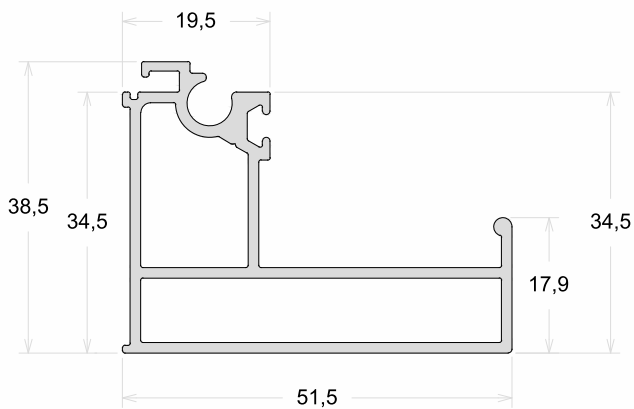

FX-245	Folha Vertical - Móvel / Fixo
Peso (Kg/m)	Perfis De Encaixe: FX-247
0,784	

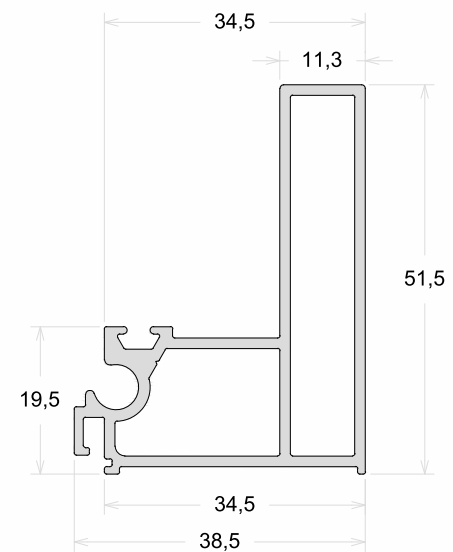

FX-405	Folha Horizontal - Móvel / Fixo Vidro Encaixilhado
Peso (Kg/m)	Perfis De Encaixe: FX-227 / FX-247
0,681	

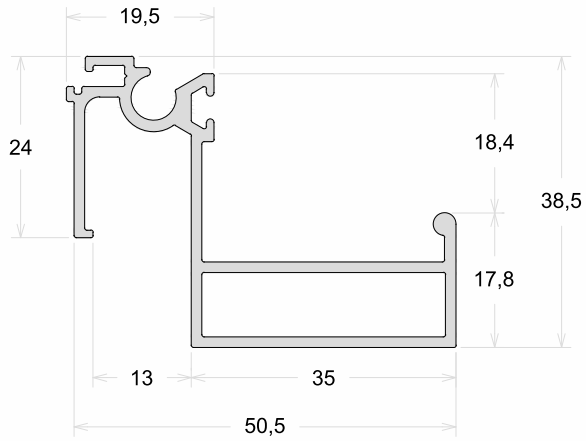

FX-403	Folha Vertical - Móvel / Fixo Vidro Encaixilhado
Peso (Kg/m)	Perfis De Encaixe: FX-247
0,646	

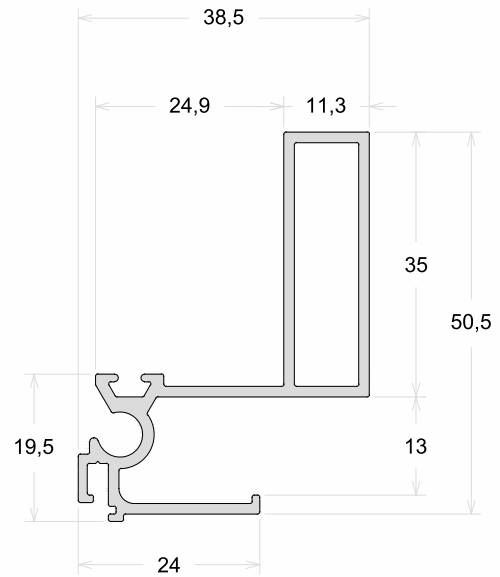

FX-231	Folha Horizontal - Fixo Vidro Insulado
Peso (Kg/m)	Perfis De Encaixe: FX-227 / FX-247
0,695	

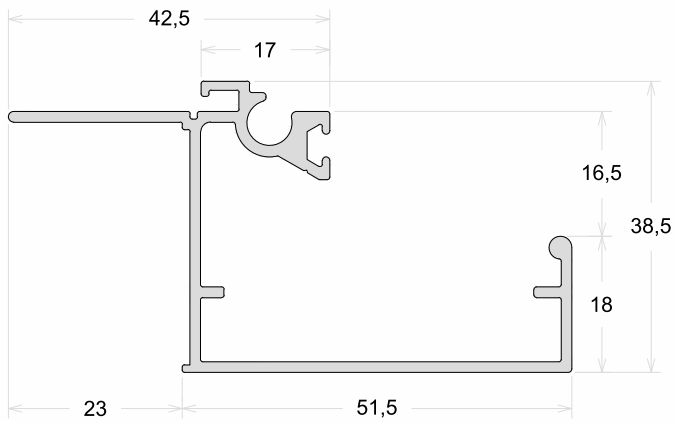

FX-229	Folha Vertical - Fixo Vidro Insulado
Peso (Kg/m)	Perfis De Encaixe: FX-247
0,660	

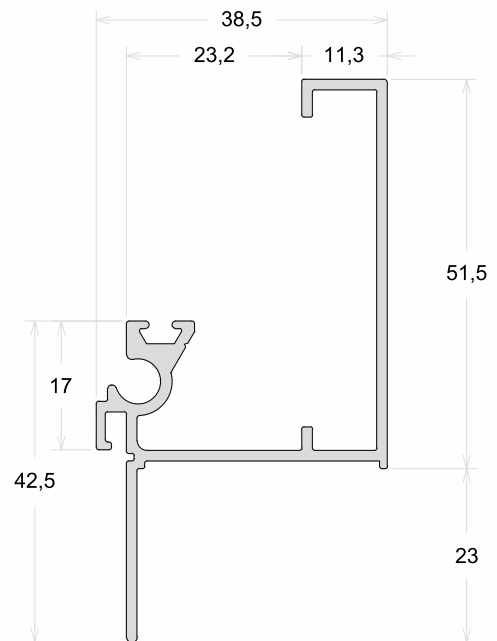

FX-234 Folha Horizontal - Móvel / Fixo
Vidro Insulado

Peso (Kg/m)
0,868

Perfis De Encaixe:
FX-227 / FX-247

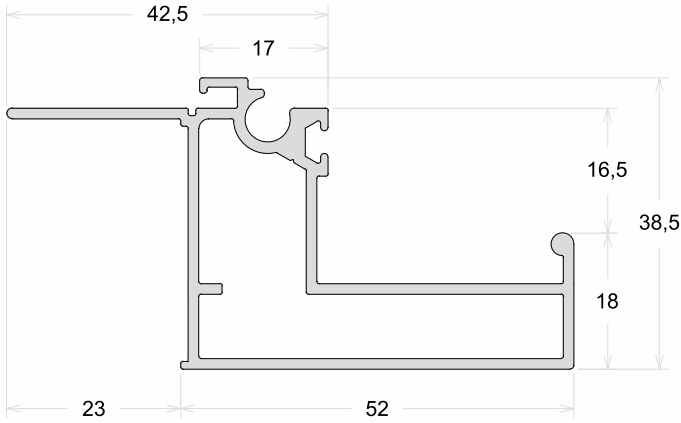

FX-246 Folha Vertical - Móvel / Fixo
Vidro Insulado

Peso (Kg/m)
0,833

Perfis De Encaixe:
FX-247

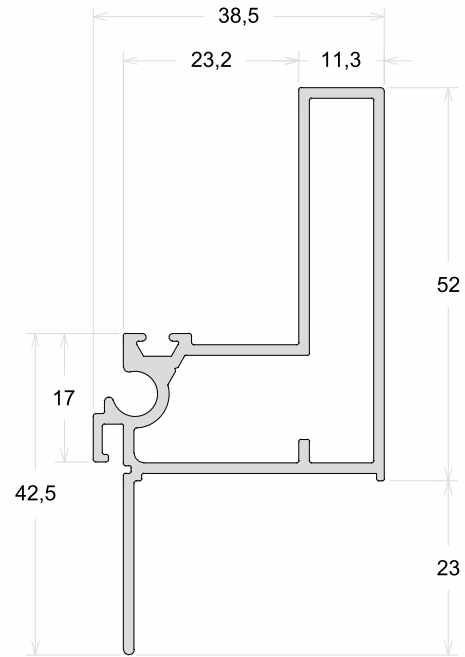

FX-291 Folha Porta De Giro L42

Peso (Kg/m)
0,913

Perfis De Encaixe:
FX-227 / FX-247 / 42-014

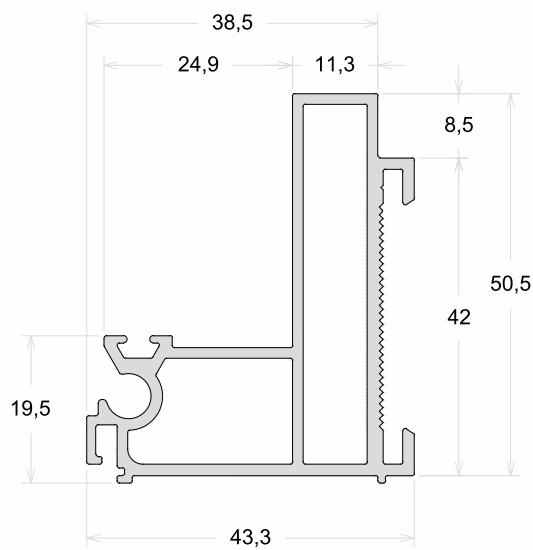

ANC-051	Ancoragem Central
Peso (Kg/m)	Perfis De Encaixe:
4,059	

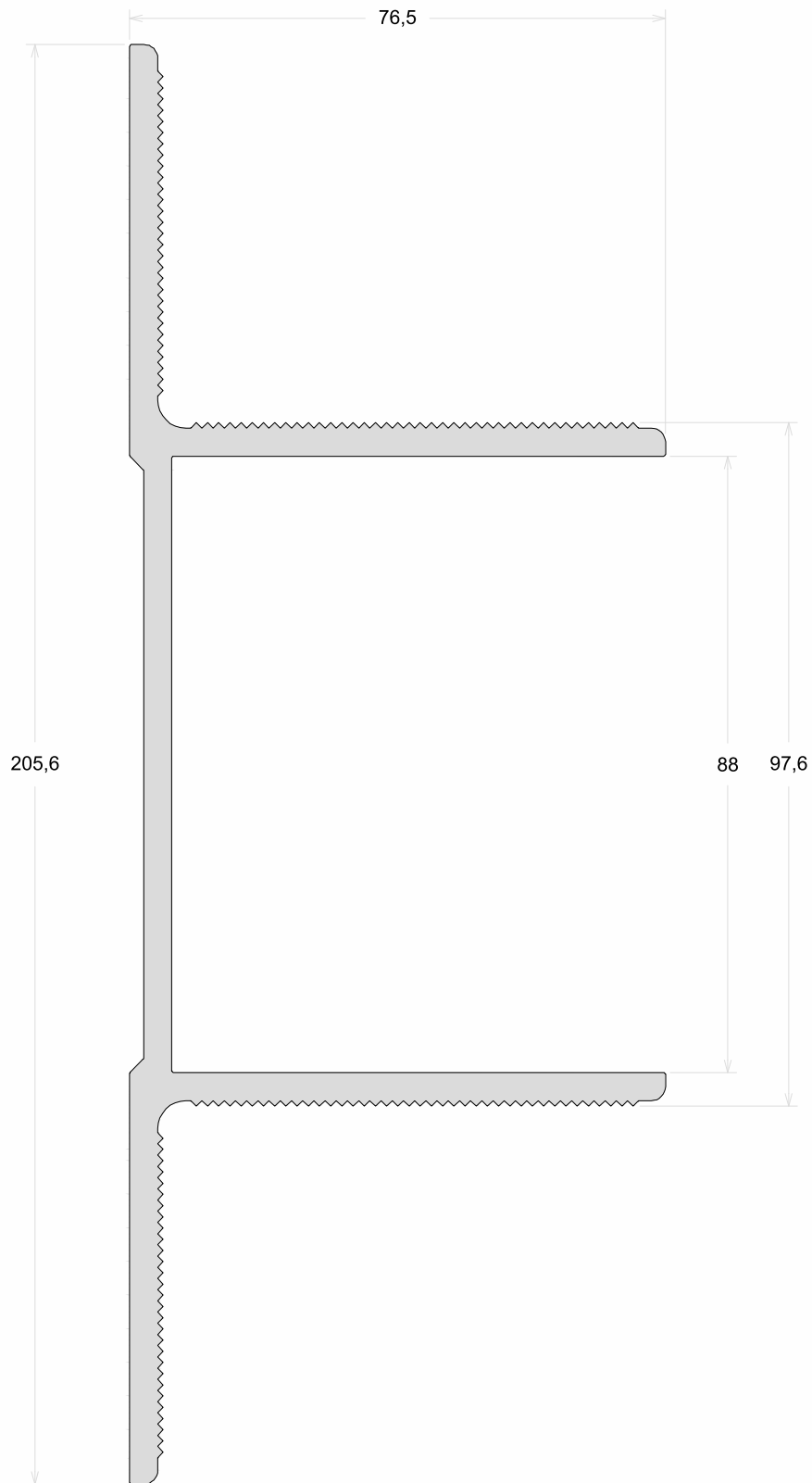

CD-004	Ancoragem Lateral
Peso (Kg/m)	Perfis De Encaixe:
1,427	

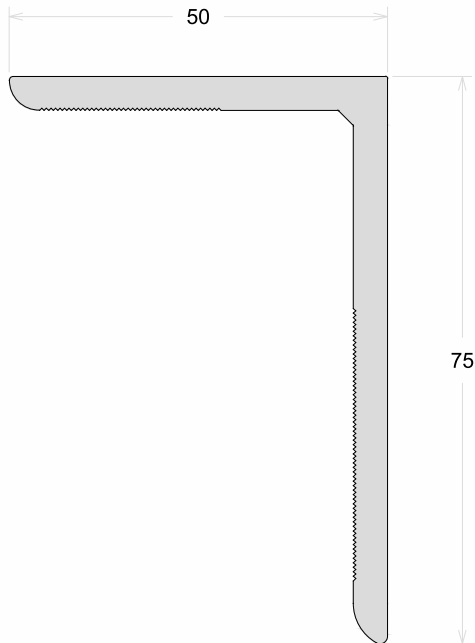

FX-397	Luva Da Travessa
Peso (Kg/m)	Perfis De Encaixe:
0,676	

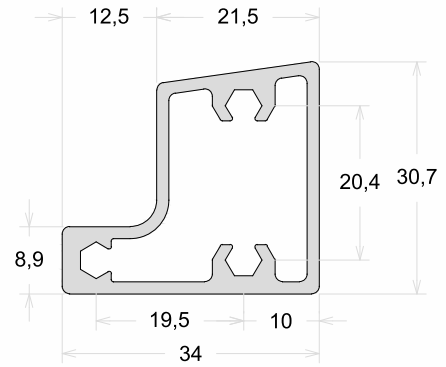

FX-273	Arremate Externo 90°
Peso (Kg/m)	Perfis De Encaixe:
0,590	FX-247

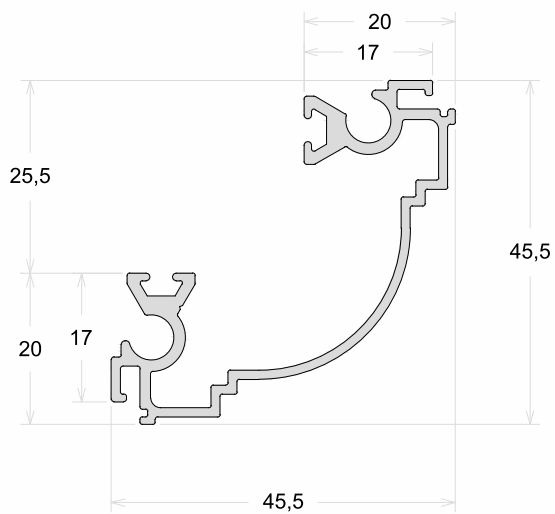

FX-269	Arremate Externo 90°
Peso (Kg/m)	Perfis De Encaixe:
0,623	FX-247

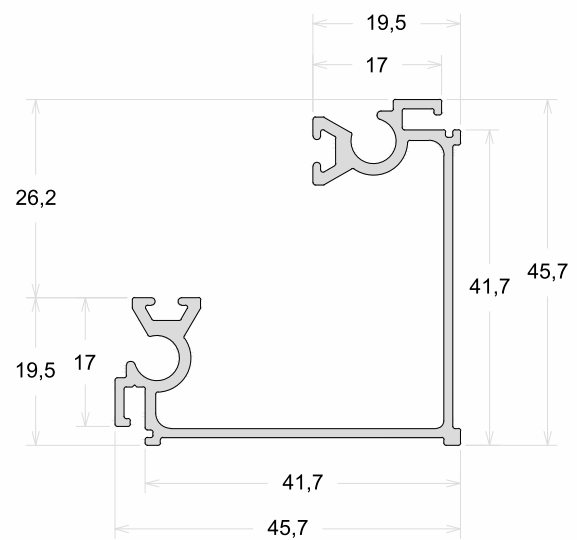

FX-227 Presilha Transversal

Peso (Kg/m) 0,245

Perfis De Encaixe: FX-233 / FX-232 / FX-230 / FX-405 / FX-231 / FX-234 / FX-291

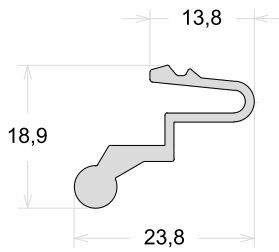

FX-226 Calço Da Folha Fixa

Peso (Kg/m) 0,369

Perfis De Encaixe: FX-233

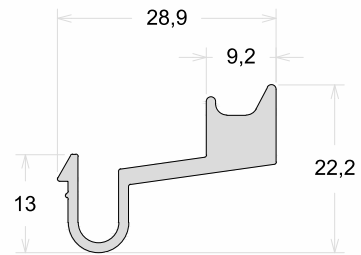

FX-247 Presilha Lateral Do Fixo

Peso (Kg/m) 0,192

Perfis De Encaixe: FX-232 / FX-228 / FX-291 / FX-230 / FX-245 / FX-403 / FX-405 / FX-231 / FX-229 / FX-234 / FX-246

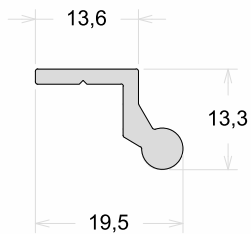

FX-240 Presilha Do Arremate De Teto e Piso

Peso (Kg/m) 0,131

Perfis De Encaixe: FX-238 / FX-239

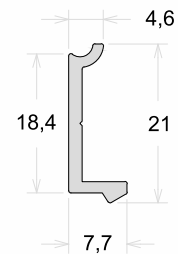

FX-239	Complemento Do Arremate
Peso (Kg/m)	Perfis De Encaixe:
0,587	FX-240 / FX-238 / FX-265

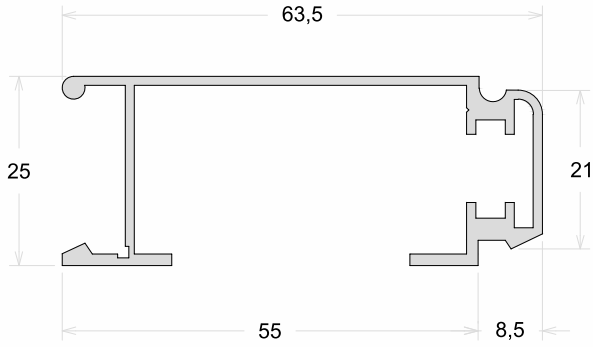

FX-238	Arremate De Teto e Piso
Peso (Kg/m)	Perfis De Encaixe:
0,519	FX-240 / FX-239 / FX-265 / FX-237

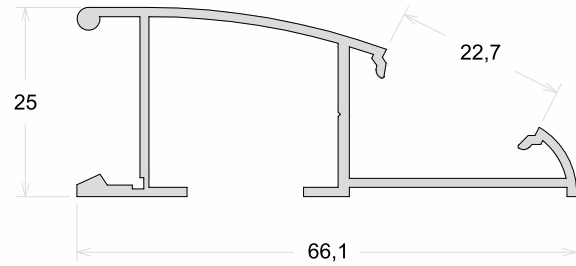

FX-265	Complemento Do Arremate
Peso (Kg/m)	Perfis De Encaixe:
0,802	FX-239 / FX-238 / FX-299

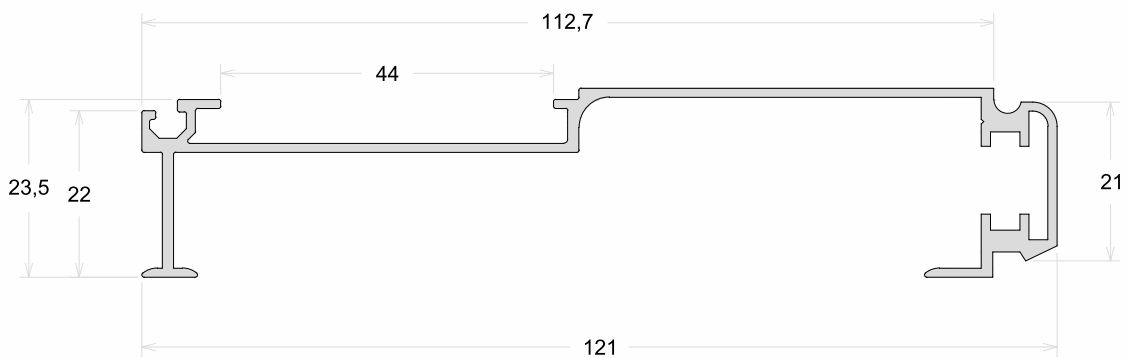

FX-237	Click Do Arremate
Peso (Kg/m)	Perfis De Encaixe: FX-238
0,116	

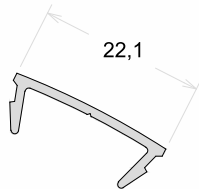

FX-299	Click Do Complemento FX-265
Peso (Kg/m)	Perfis De Encaixe: FX-265
0,224	

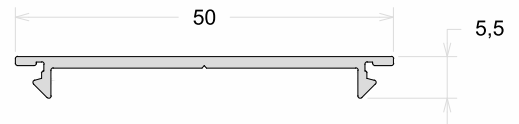

FX-300	Luva Do Complemento FX-265
Peso (Kg/m)	Perfis De Encaixe: FX-265
0,792	

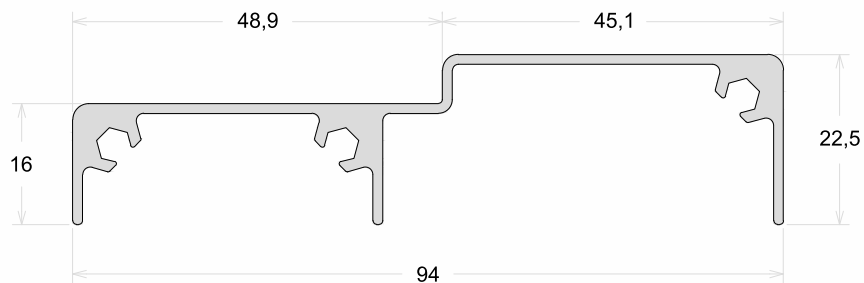

PPV-010	Coluna Central 34mm
Peso (Kg/m)	Perfis De Encaixe:
0,884	

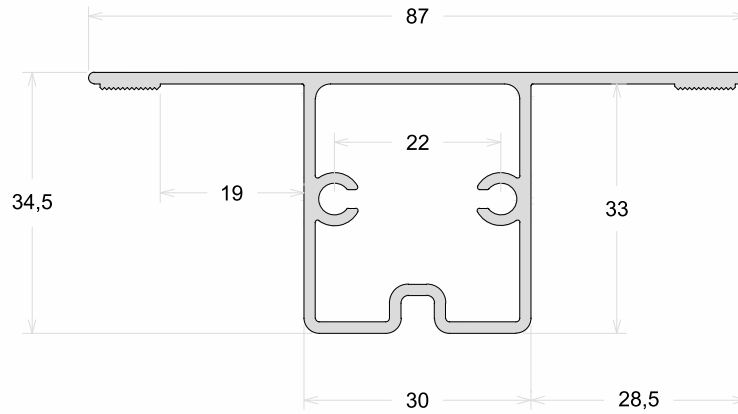

PPV-017	Coluna Central 53mm
Peso (Kg/m)	Perfis De Encaixe:
1,184	

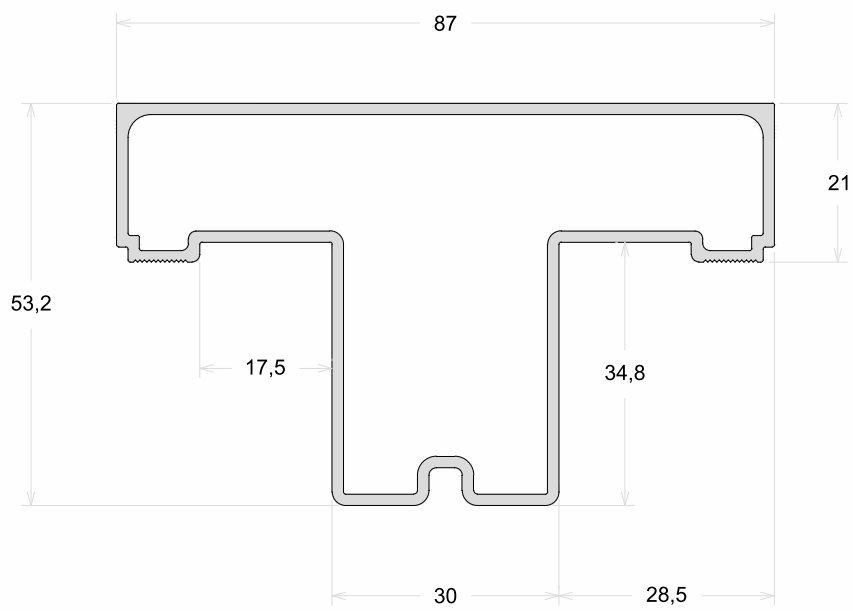

PPV-008	Coluna Central 73mm
Peso (Kg/m)	Perfis De Encaixe:
1,685	

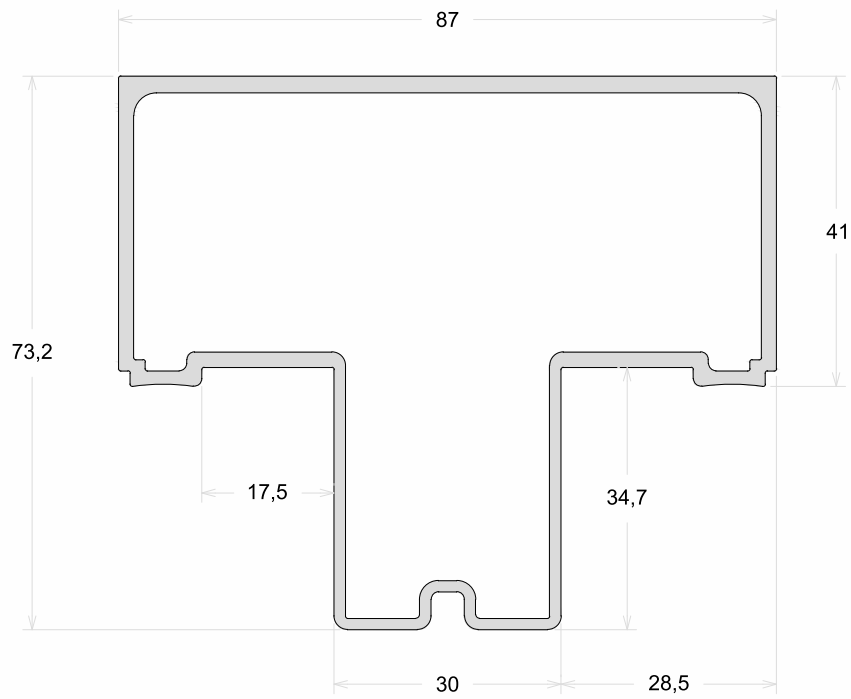

PPV-005	Coluna Central 97mm
Peso (Kg/m)	Perfis De Encaixe:
2,054	

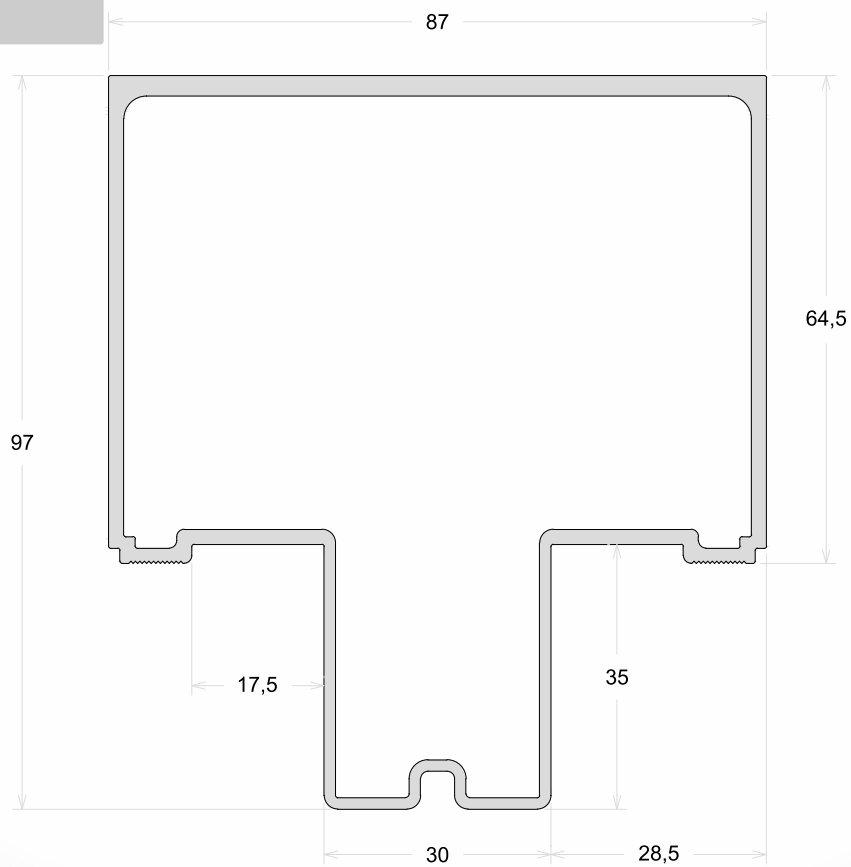

PPV-014	Luva Da Coluna Central
Peso (Kg/m)	Perfis De Encaixe:
0,555	

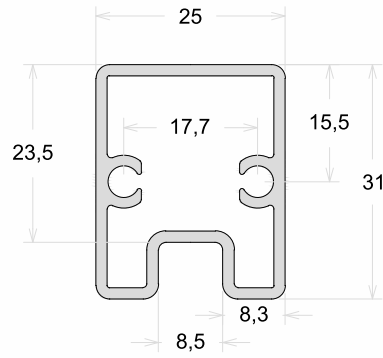

PPV-006	Luva Da Coluna 97mm
Peso (Kg/m)	Perfis De Encaixe:
1,694	

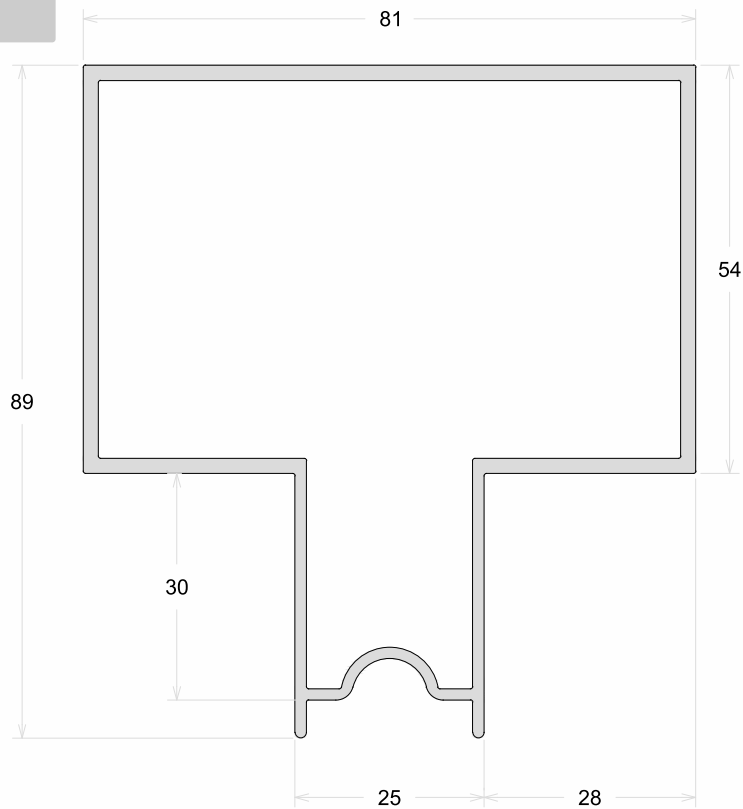

PPV-015	Coluna Central 171°
Peso (Kg/m)	Perfis De Encaixe:
1,633	

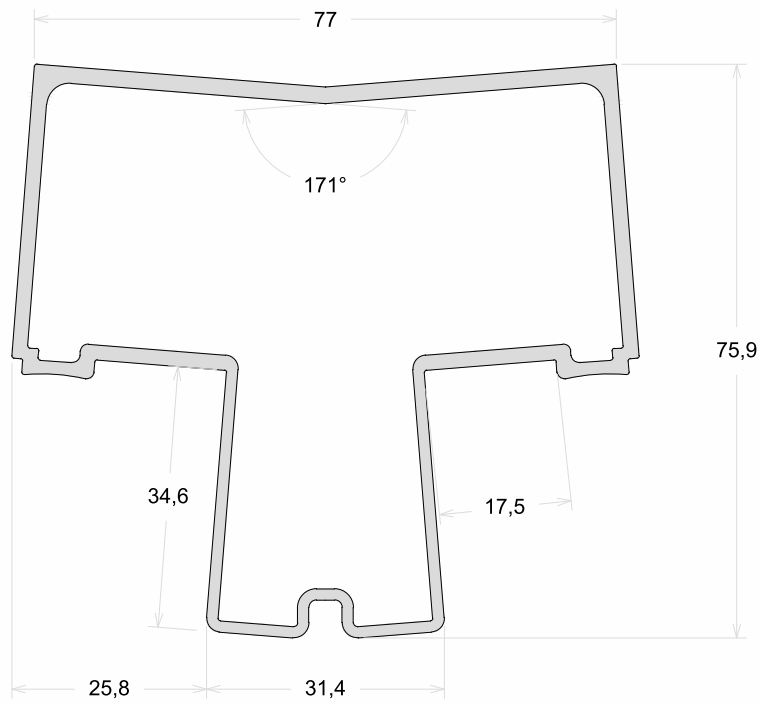

PPV-033	Coluna Central 175°
Peso (Kg/m)	Perfis De Encaixe:
1,819	

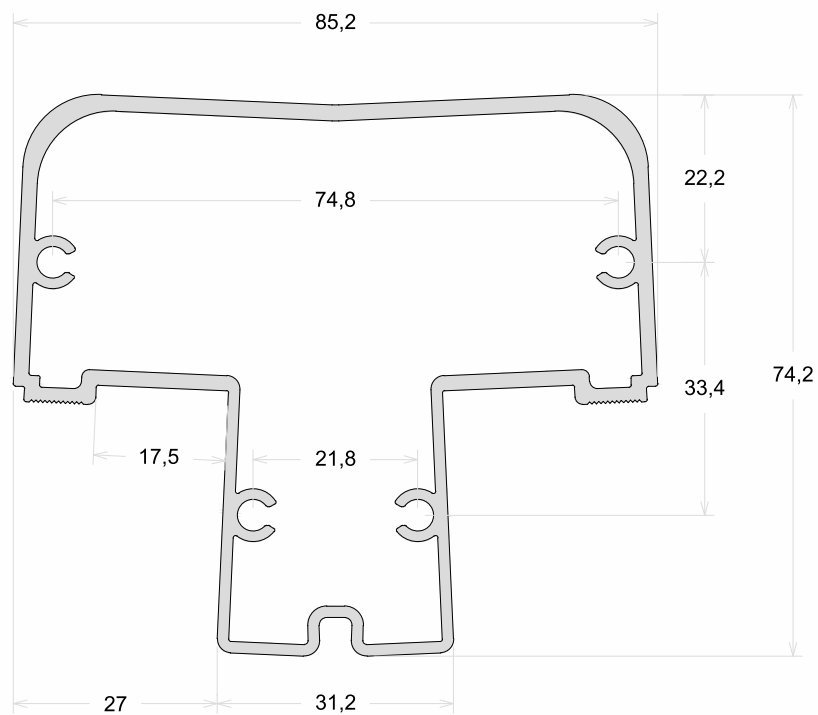

PPV-030	Coluna 90°
Peso (Kg/m)	Perfis De Encaixe:
1,678	

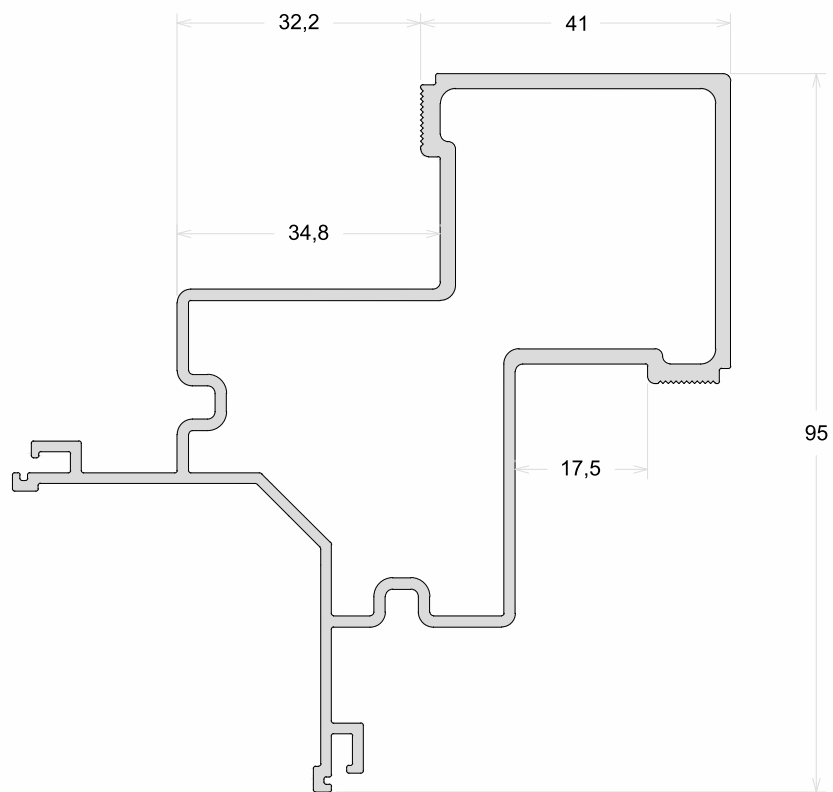

PPV-022	Coluna 90 °
Peso (Kg/m)	Perfis De Encaixe:
2,146	

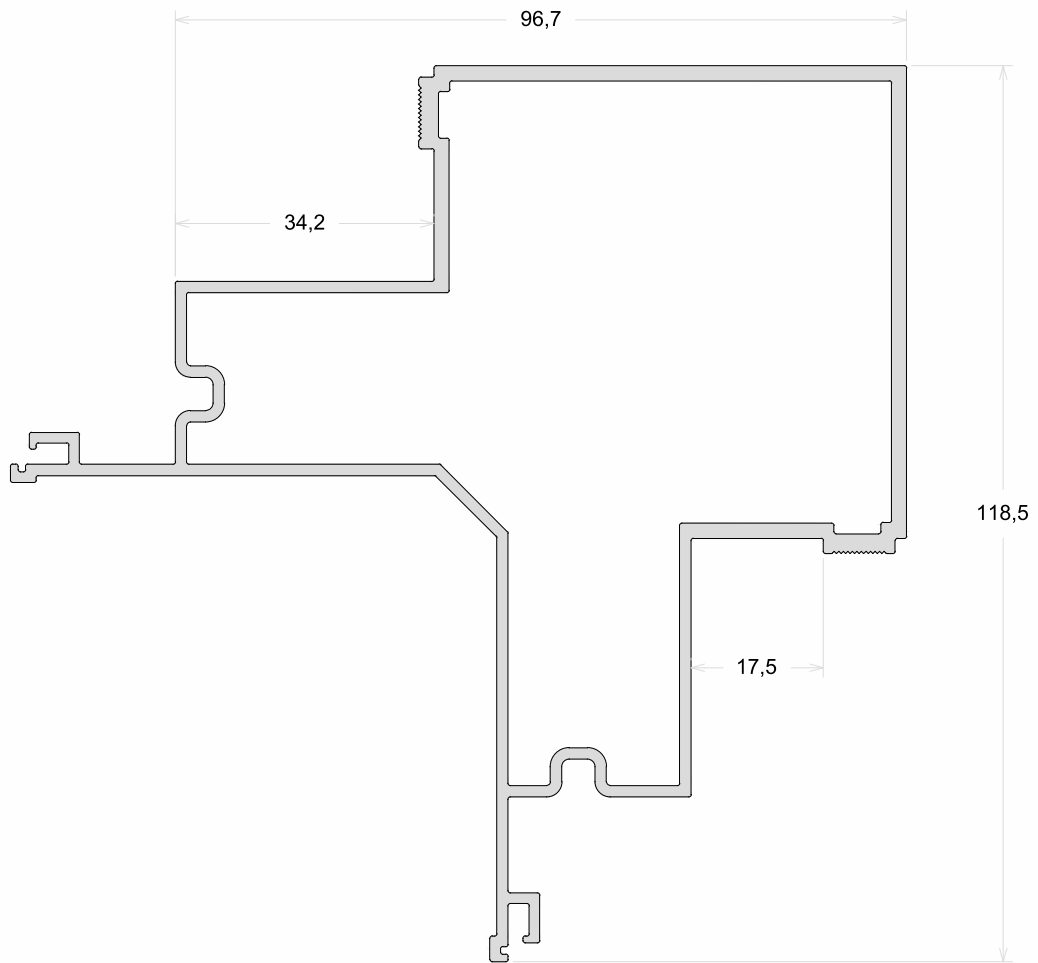

PPV-016	Travessa
Peso (Kg/m)	Perfis De Encaixe:
0,850	

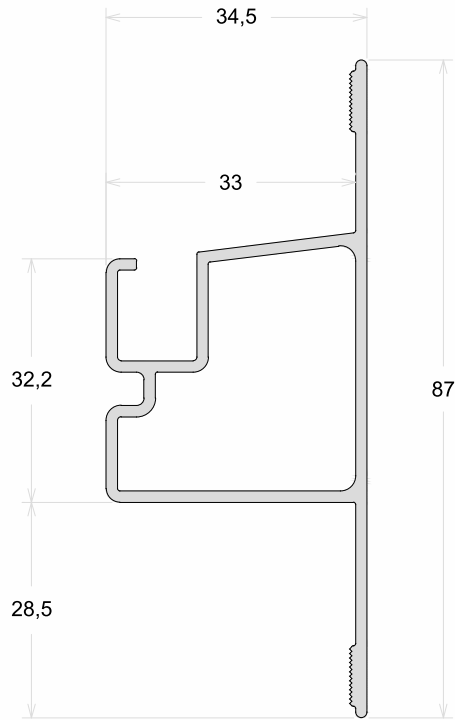

PPV-011	Marco Para Coluna 34mm
Peso (Kg/m)	Perfis De Encaixe:
0,747	

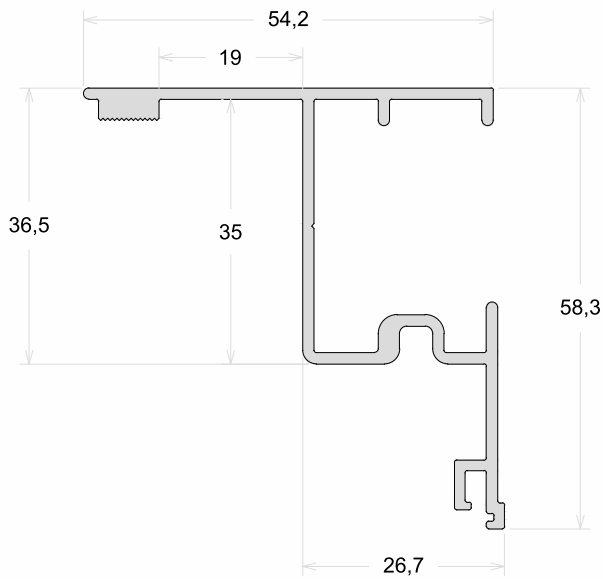

PPV-018	Marco Para Coluna 53mm
Peso (Kg/m)	Perfis De Encaixe:
0,937	

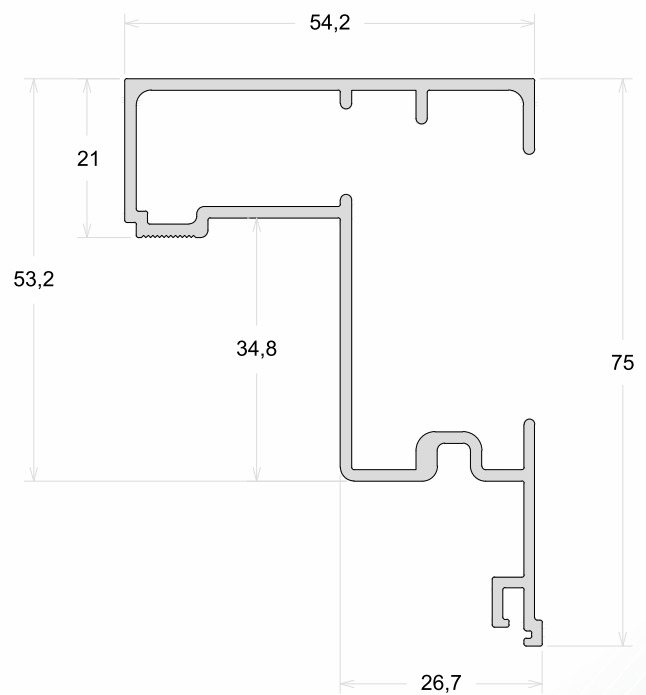

PPV-009	Marco Para Coluna 73mm
Peso (Kg/m)	Perfis De Encaixe:
1,166	

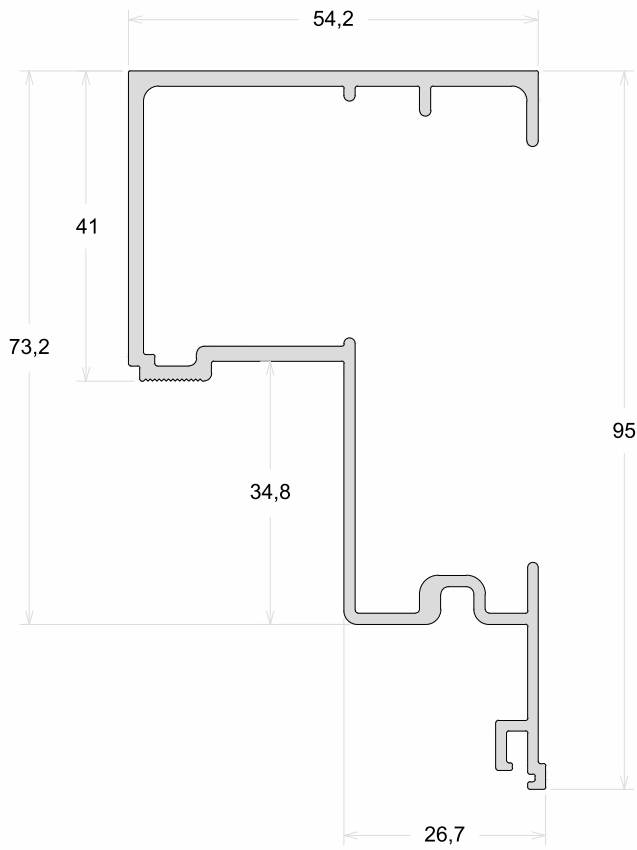

PPV-007	Marco Para Coluna 97mm
Peso (Kg/m)	Perfis De Encaixe:
1,328	

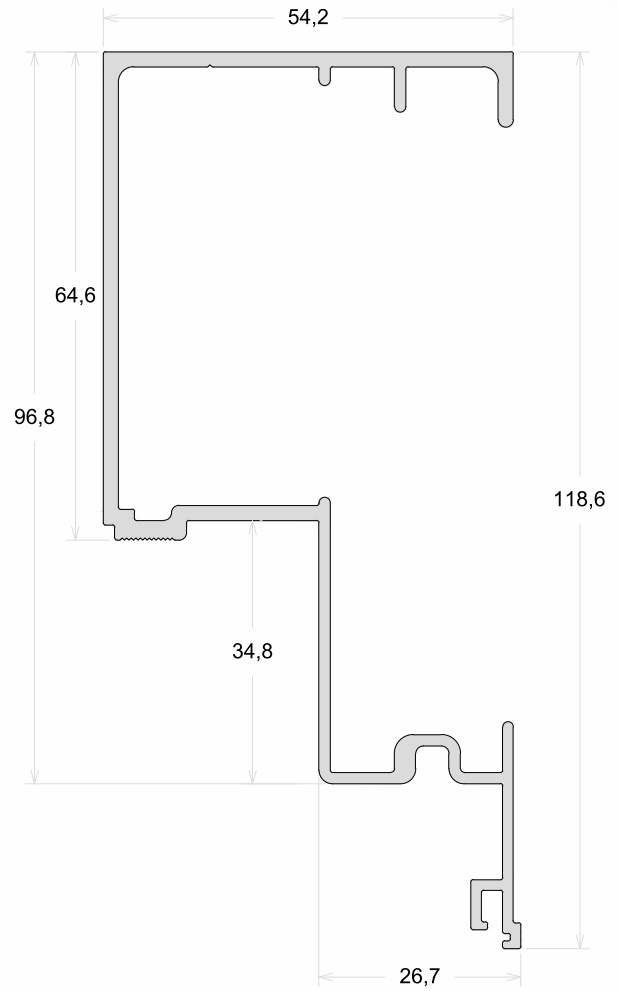

PPV-029	Acabamento Marco Lateral
Peso (Kg/m)	Perfis De Encaixe:
0,271	

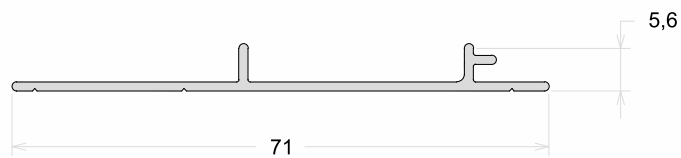

PPV-012	Folha Fixa
Peso (Kg/m)	Perfis De Encaixe: FX-247 / PPV-023
0,598	

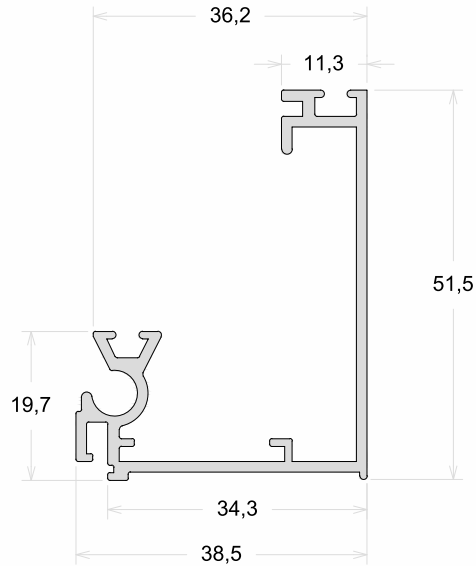

PPV-025	Folha Horizontal - Móvel / Fixa
Peso (Kg/m)	Perfis De Encaixe: PPV-023 / FX-247
0,797	

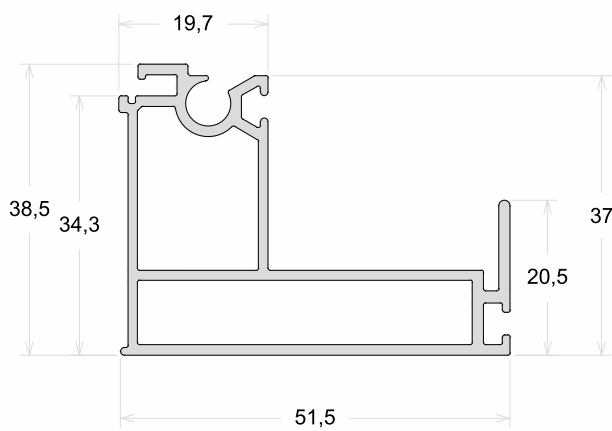

PPV-013	Folha Vertical - Móvel / Fixa
Peso (Kg/m)	Perfis De Encaixe:
0,755	

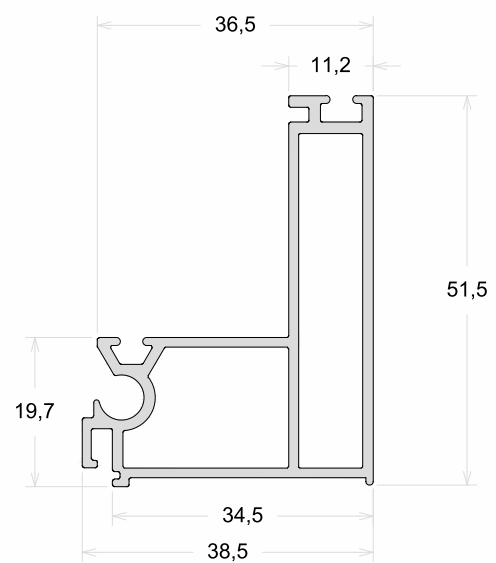

PPV-032	Folh Fixa
Peso (Kg/m)	Perfis De Encaixe: FX-247 / PPV-023
0,605	

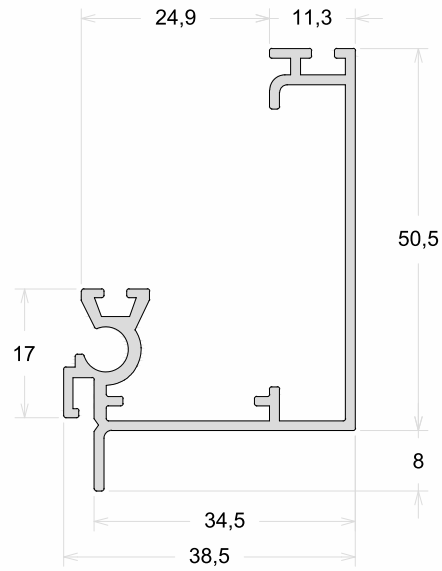

PPV-031	Folha - Móvel / Fixa
Peso (Kg/m)	Perfis De Encaixe: FX-247 / PPV-023
0,793	

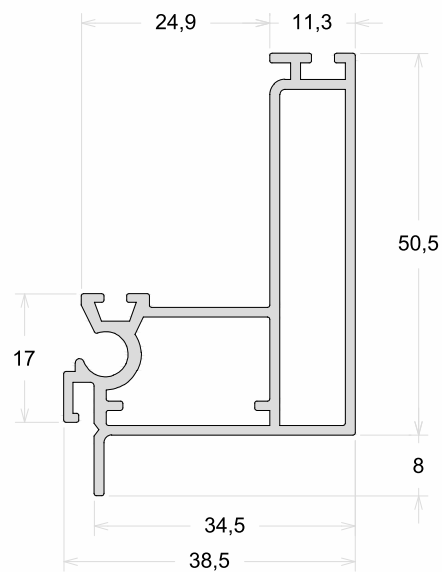

ANC-051	Ancoragem Central
Peso (Kg/m)	Perfis De Encaixe:
4,059	

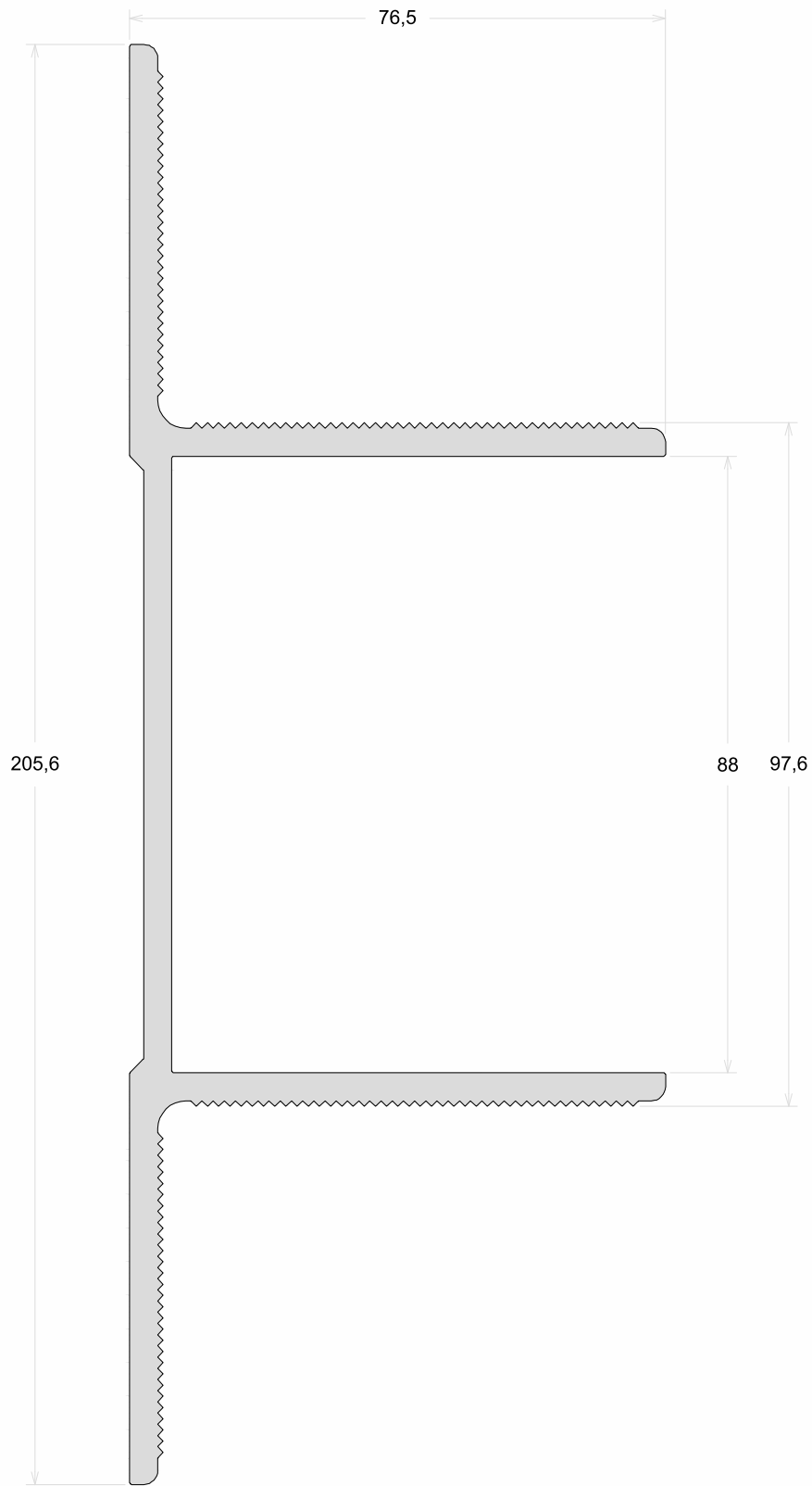

CD-004	Ancoragem Lateral
Peso (Kg/m)	Perfis De Encaixe:
1,427	

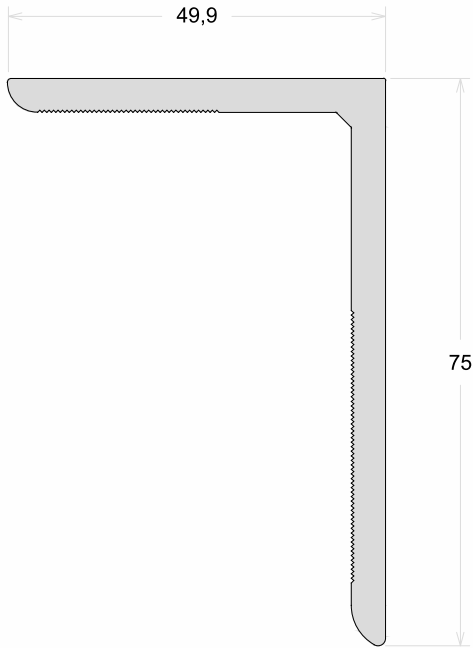

PPV-024	Calço Da Folha Fixa
Peso (Kg/m)	Perfis De Encaixe:
0,375	PPV-016

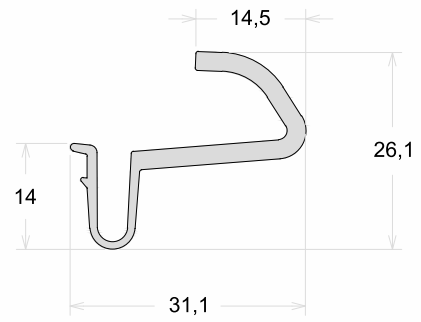

PPV-023	Presilha Da Folha Fixa
Peso (Kg/m)	Perfis De Encaixe:
0,223	

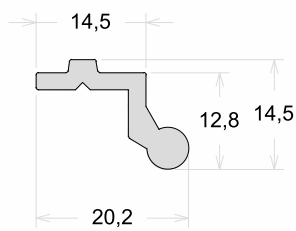

FX-247	Presilha Da Folha Fixa
Peso (Kg/m)	Perfis De Encaixe:
0,192	

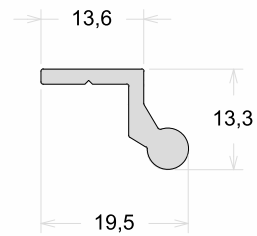

PPV-020	Complemento Do Arremate De Teto e Piso
Peso (Kg/m)	Perfis De Encaixe:
0,328	



PPV-019	Arremate De Teto e Piso
Peso (Kg/m)	Perfis De Encaixe: PAL-013
0,325	

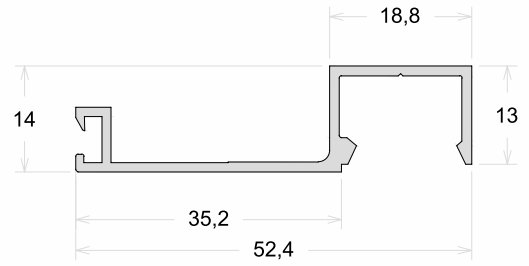

PPV-021	Complemento Do Arremate De Teto e Piso
Peso (Kg/m)	Perfis De Encaixe:
0,465	

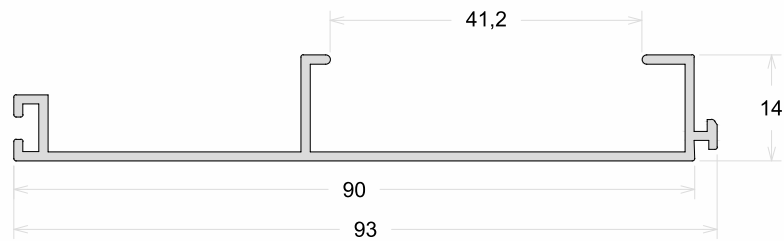

MFS-044	Coluna Central 38mm
Peso (Kg/m)	Perfis De Encaixe:
1,034	

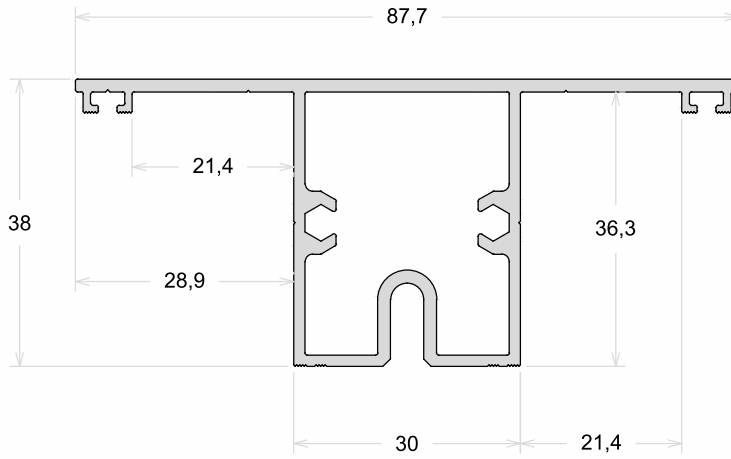

MFS-370	Coluna Central 56mm
Peso (Kg/m)	Perfis De Encaixe:
1,454	

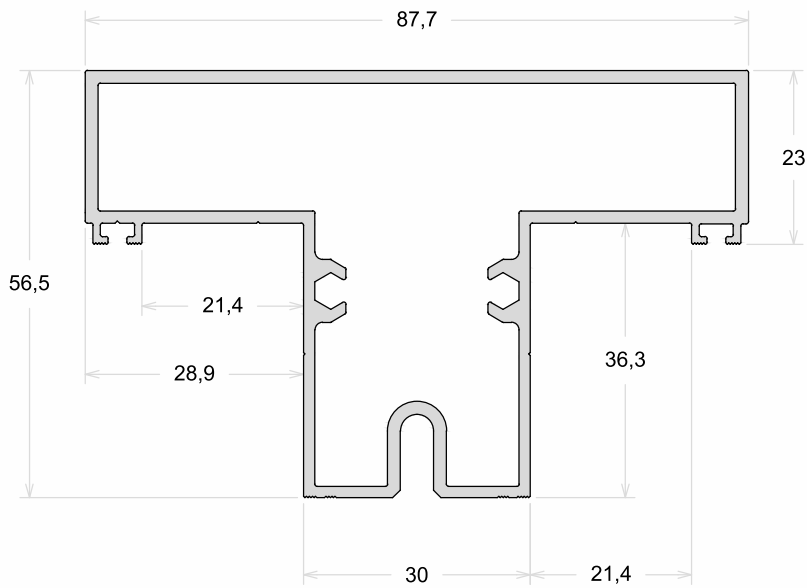

MFS-020	Coluna Central 97mm
Peso (Kg/m)	Perfis De Encaixe:
1,988	

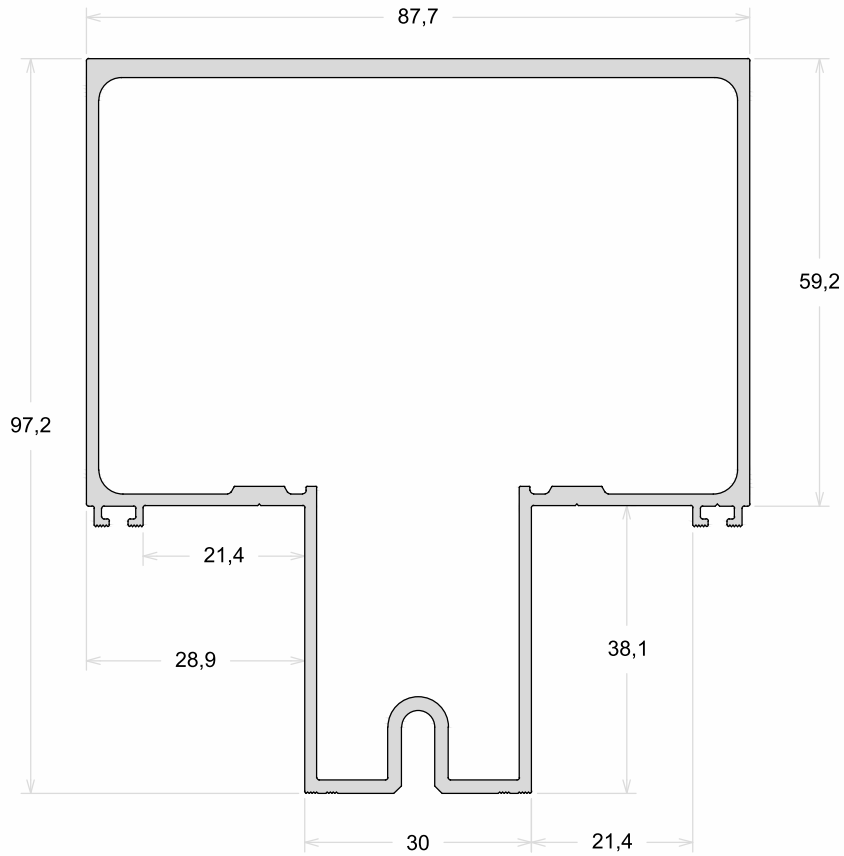

MFS-002	Travessa
Peso (Kg/m)	Perfis De Encaixe:
0,899	

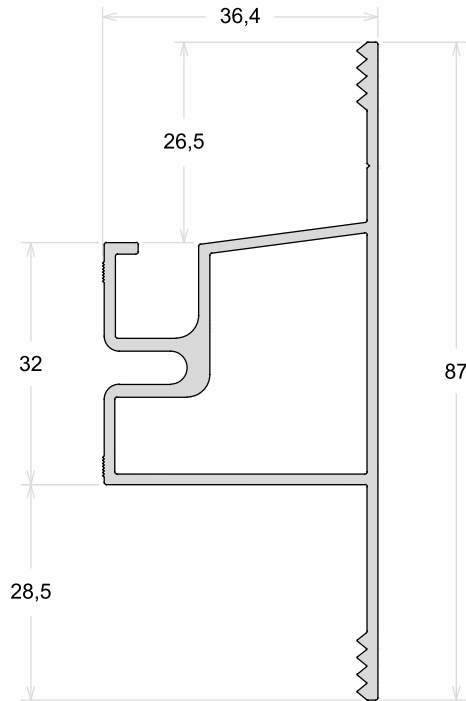

MFS-042	Coluna 90°
Peso (Kg/m)	Perfis De Encaixe:
1,404	

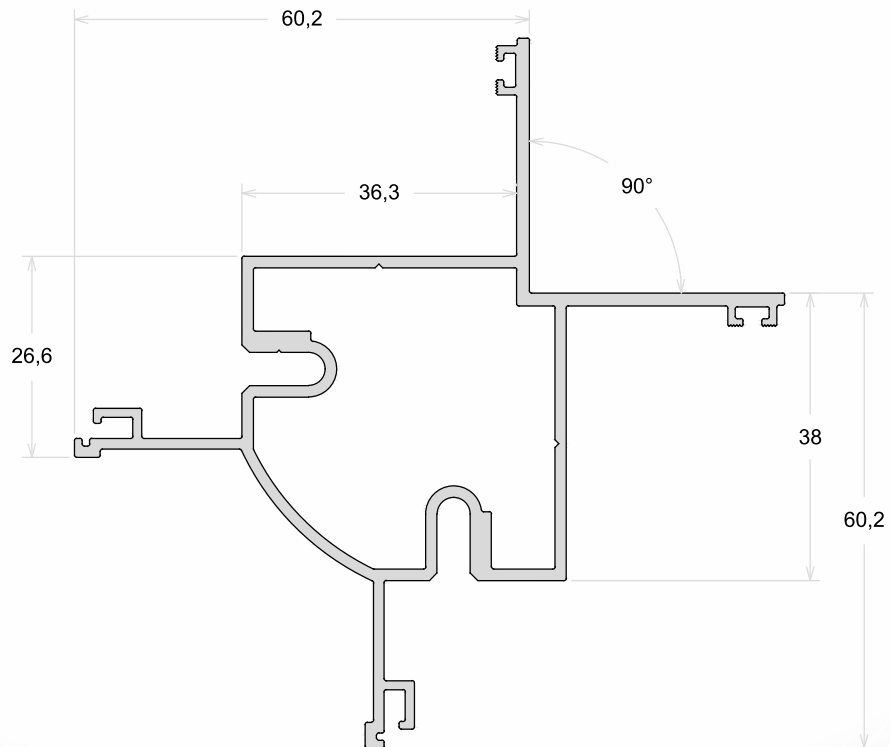

MFS-007	Marco 38mm
Peso (Kg/m)	Perfis De Encaixe:
0,793	

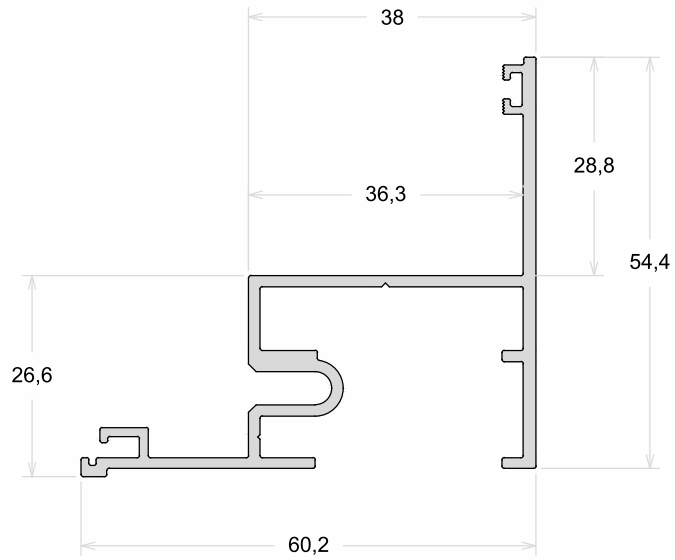

MFS-032	Marco 70mm
Peso (Kg/m)	Perfis De Encaixe:
1,041	

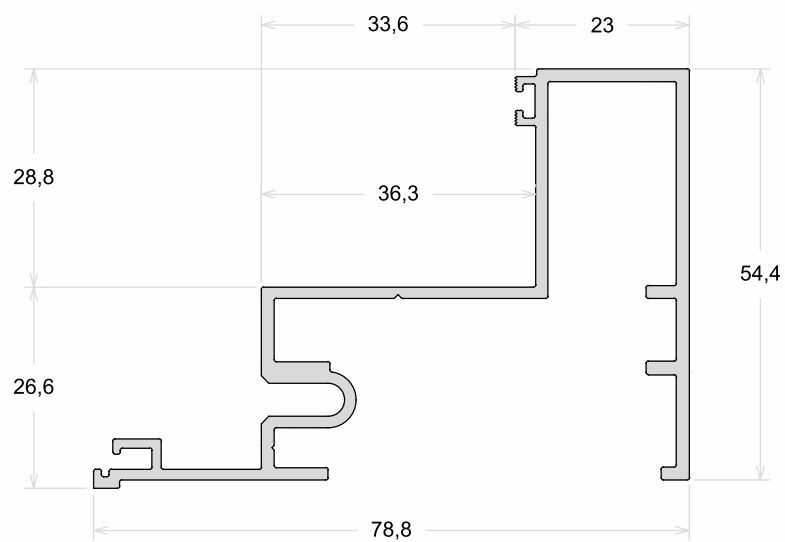

MFS-023	Marco 97mm
Peso (Kg/m)	Perfis De Encaixe:
1,394	

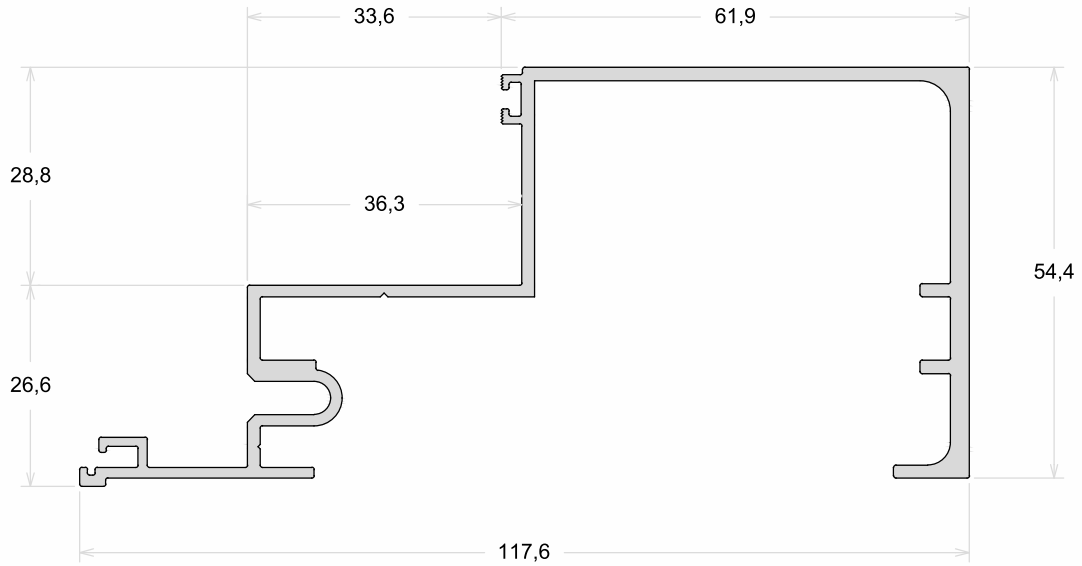

MFS-024	Marco 97mm
Peso (Kg/m)	Perfis De Encaixe:
1,634	

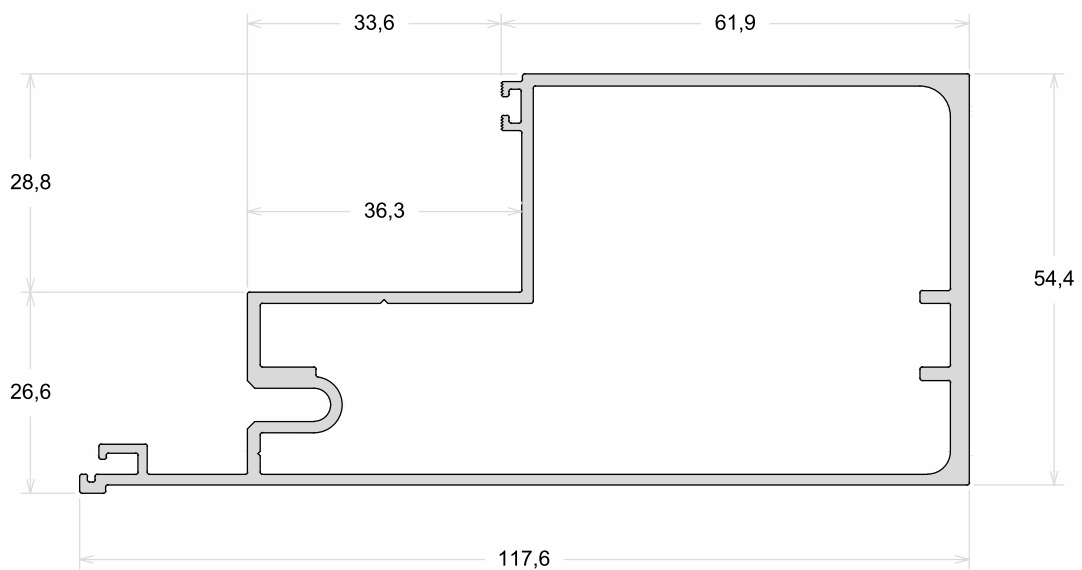

MFS-006	Folha Fixa (Silicone Estrutural)
Peso (Kg/m)	Perfis De Encaixe:
0,585	

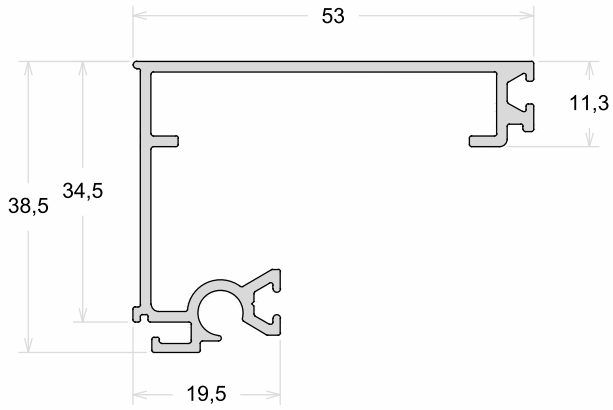

MFS-005	Folha Móvel (Silicone Estrutural)
Peso (Kg/m)	Perfis De Encaixe:
0,793	

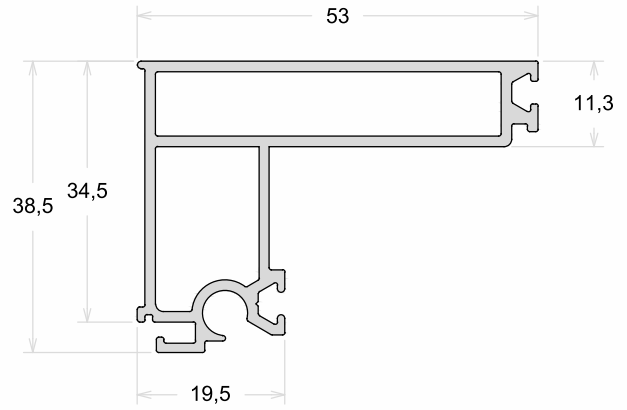

MFS-013	Folha Fixa (Fita VHB)
Peso (Kg/m)	Perfis De Encaixe:
0,602	

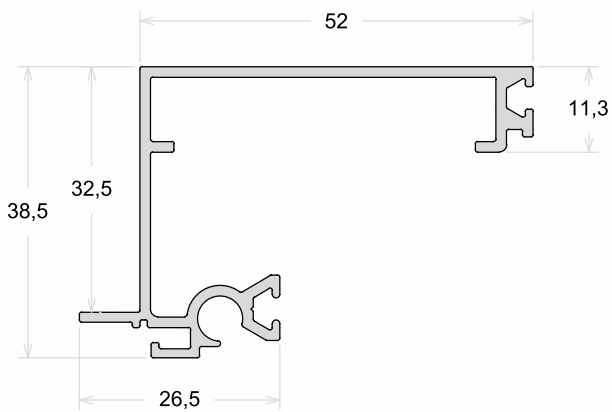

MFS-015	Folha Fixa (Fita VHB)
Peso (Kg/m)	Perfis De Encaixe:
0,815	

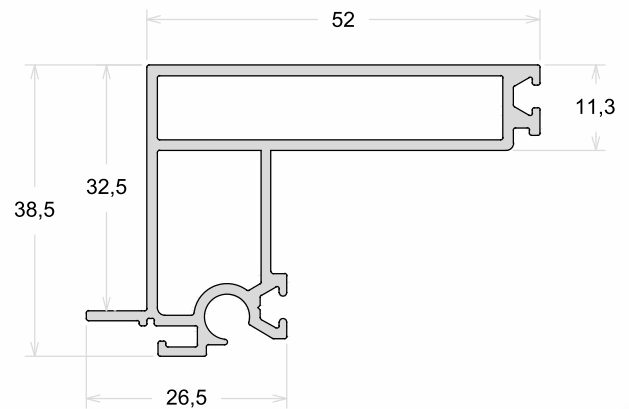

PAT-202	Coluna Central
Peso (Kg/m)	Perfis De Encaixe:
1,687	

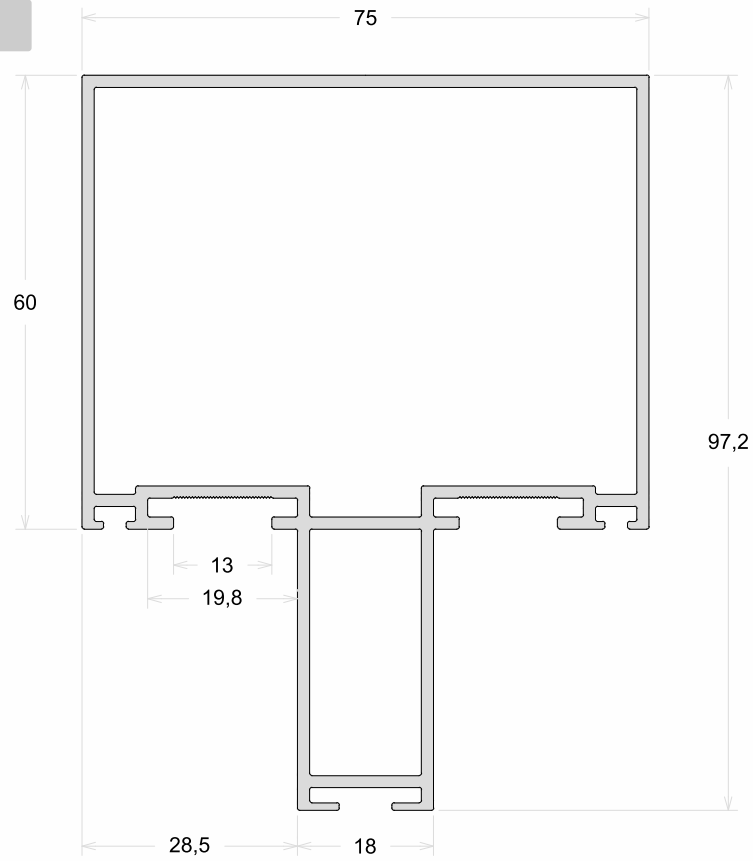

PAT-243	Marco
Peso (Kg/m)	Perfis De Encaixe:
1,064	

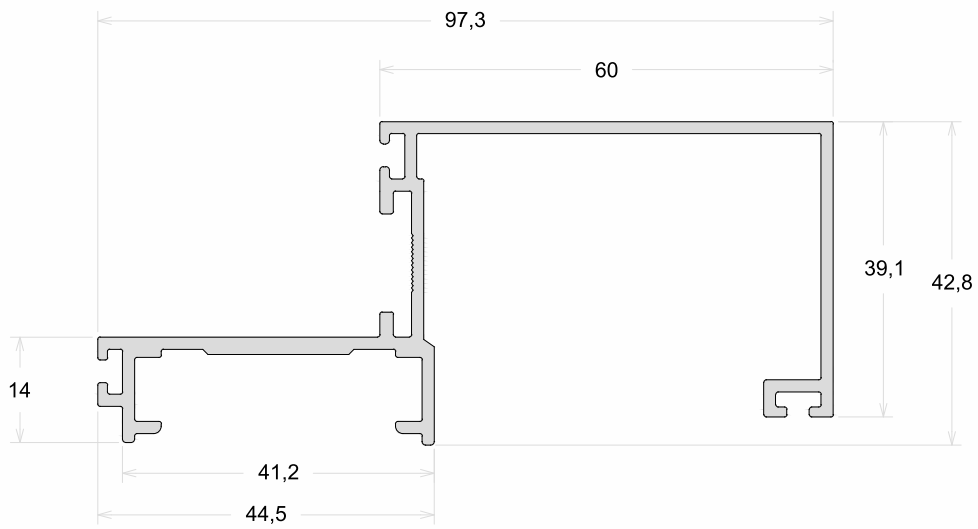

PAT-225	Marco
Peso (Kg/m)	Perfis De Encaixe:
0,664	

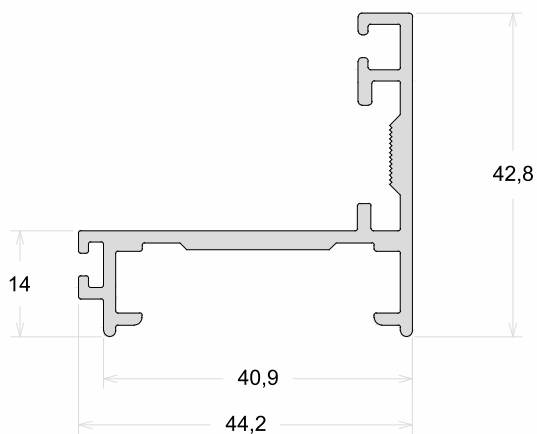

FC-687	Pingadeira
Peso (Kg/m)	Perfis De Encaixe:
0,455	

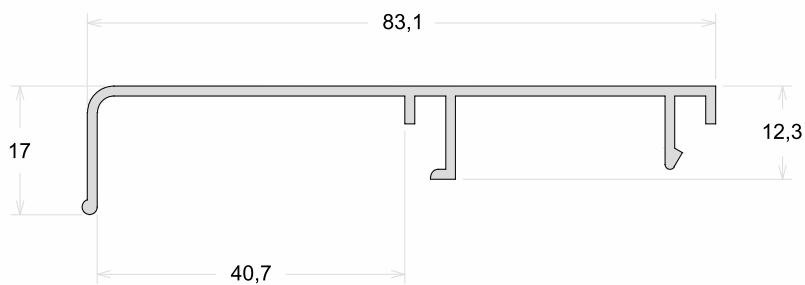

PAT-231	Coluna / Travessa
Peso (Kg/m)	Perfis De Encaixe:
1,049	

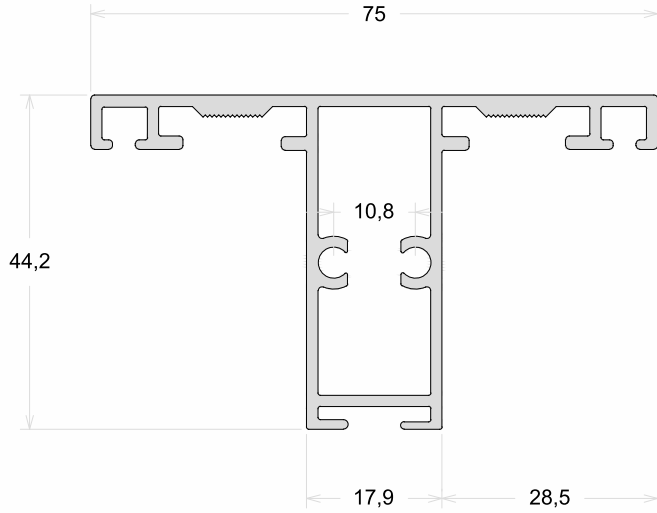

FC-231	Coluna / Travessa
Peso (Kg/m)	Perfis De Encaixe:
1,059	

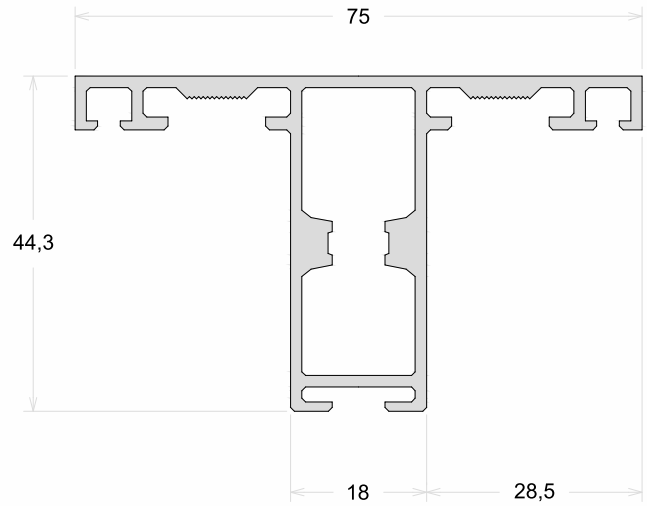

PAT-227	Complemento Da Folha
Peso (Kg/m)	Perfis De Encaixe:
0,687	

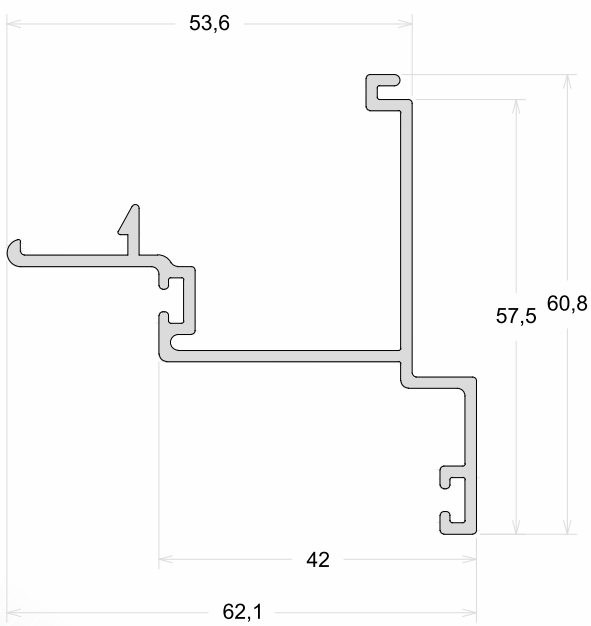

PAT-249	Complemento Da Folha
Peso (Kg/m)	Perfis De Encaixe:
0,610	

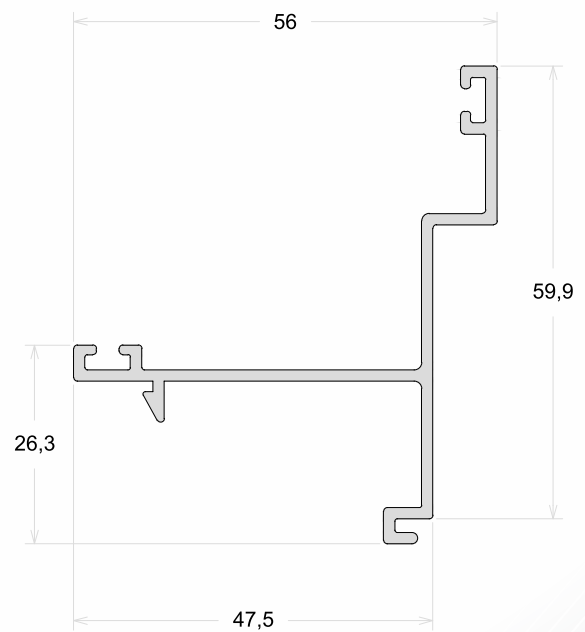

PAT-261	Folha Móvel / Fixa
Peso (Kg/m)	Perfis De Encaixe:
0,560	

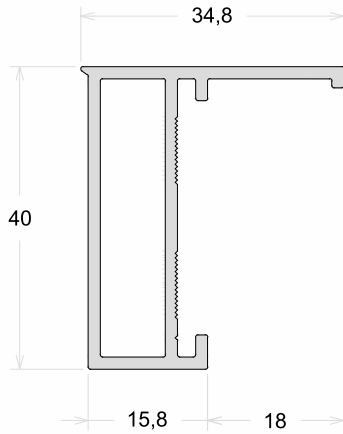

PAT-228	Folha Móvel / Fixa
Peso (Kg/m)	Perfis De Encaixe:
0,566	

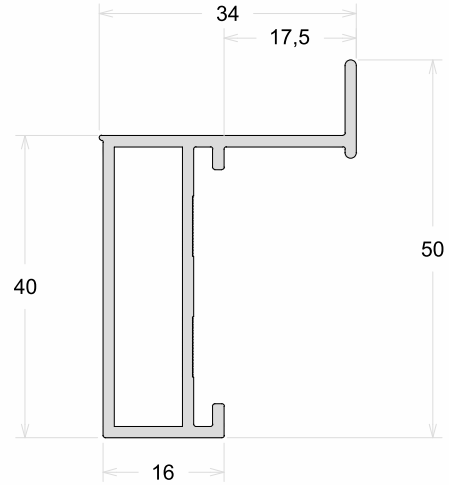

FC-293	Folha Móvel / Fixa
Peso (Kg/m)	Perfis De Encaixe:
0,645	

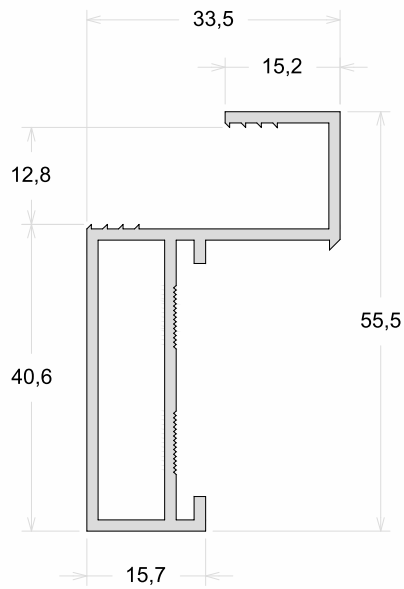

PFC-001	Coluna
Peso (Kg/m)	Perfis De Encaixe:
1,011	

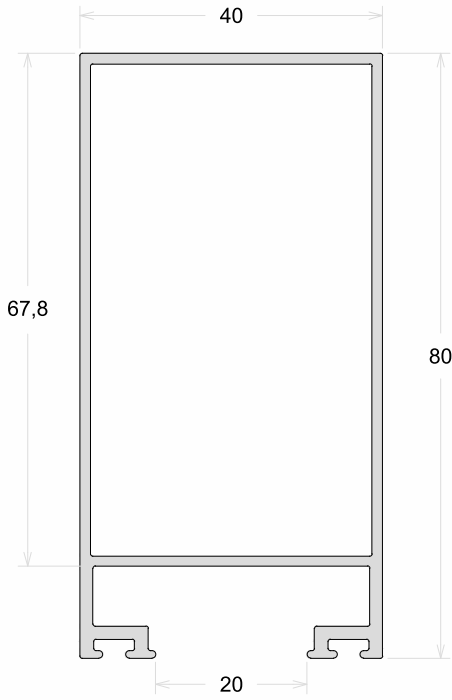

A-072	Coluna
Peso (Kg/m)	Perfis De Encaixe:
1,269	

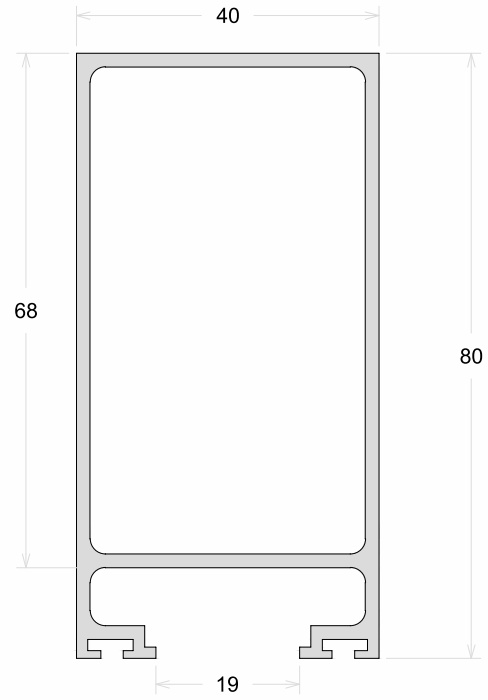

PFC-003	Fixador
Peso (Kg/m)	Perfis De Encaixe:
0,309	

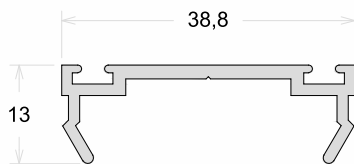

PFC-002	Capa Do Fixador
Peso (Kg/m)	Perfis De Encaixe:
0,275	



PFC-017	Coluna
Peso (Kg/m)	Perfis De Encaixe:
1,856	

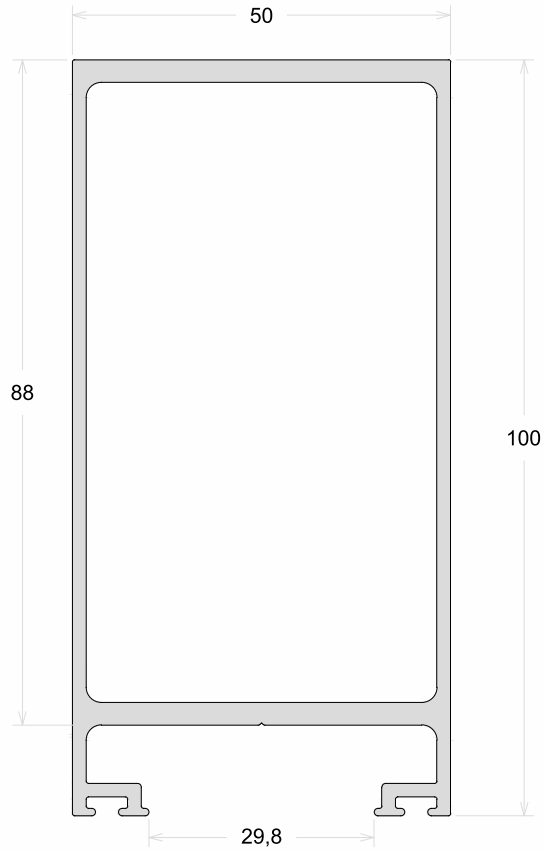

PFC-543	Fixador
Peso (Kg/m)	Perfis De Encaixe:
0,433	



PFC-542	Capa Do Fixador
Peso (Kg/m)	Perfis De Encaixe:
0,350	



U-878	Fixador
Peso (Kg/m)	Perfis De Encaixe:
0,371	

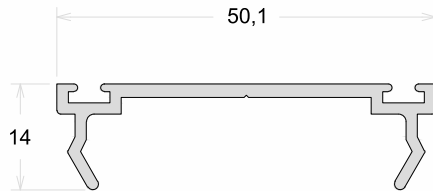

U-1086	Fixador
Peso (Kg/m)	Perfis De Encaixe:
0,409	

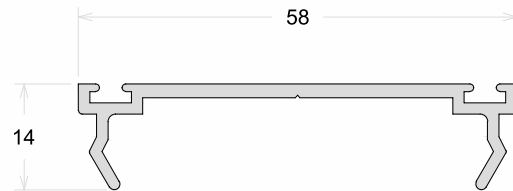

U-877	Capa Do Fixador
Peso (Kg/m)	Perfis De Encaixe:
0,399	



U-1312	Capa Do Fixador
Peso (Kg/m)	Perfis De Encaixe:
0,366	

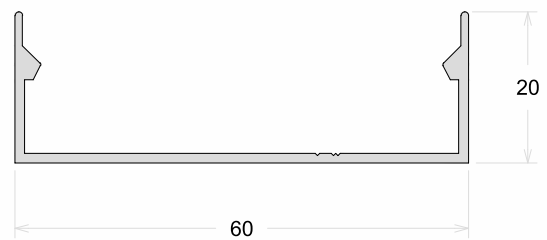

U-615	Fixador
Peso (Kg/m)	Perfis De Encaixe:
0,362	

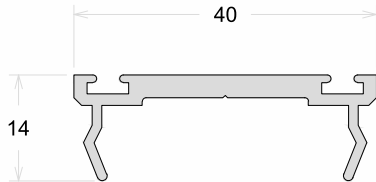

U-621	Capa Do Fixador
Peso (Kg/m)	Perfis De Encaixe:
0,222	



PFC-004	Fixador
Peso (Kg/m)	Perfis De Encaixe:
0,201	

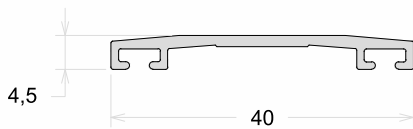

PFC-005	Fixador
Peso (Kg/m)	Perfis De Encaixe:
0,234	

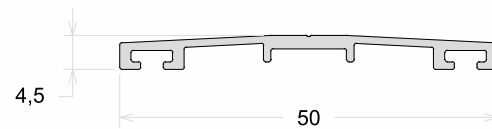

PERFISUD

EXTRUSÃO DE ALUMÍNIO

COLORSUD

TECNOLOGIA EM PINTURA

  @perfisud

Rodovia SC 370 – KM 170, S/N
Pouso Alto | Gravatal | SC
88735-000 | Brasil
+55 48 3628-0666

PERFISUD.COM.BR

