

INFINITY CLASS

Portas

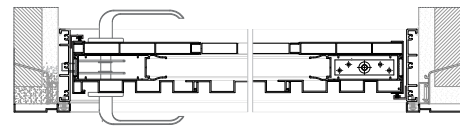

PERFISUD
EXTRUSÃO DE ALUMÍNIO

CATÁLOGO TÉCNICO





Localizada na cidade de Gravatal, Santa Catarina, a **PERFISUD** atende a demanda de extrusão de alumínio, desde 2007, com eficiência e comprometimento.

A PERFISUD conta com 2 prensas de 5" e 1 de 7", tendo uma capacidade instalada de 1.500 ton/mês.

No ano de 2021, a PERFISUD inaugurou uma unidade de pintura eletrostática, a **COLORSUD**. Uma linha Power Free moderna, inovadora e altamente tecnológica. Com laboratório próprio, atendendo todas as normas para a garantia do processo e qualidade do serviço prestado. A COLORSUD tem como parceiros os melhores fornecedores, homologados **Qualicoat**. Tudo isso para lhe entregar um produto altamente qualificado e seguro, que com certeza irá superar suas expectativas.

PERFISUD
 EXTRUSÃO DE ALUMÍNIO

COLORSUD
 TECNOLOGIA EM PINTURA

Missão

Atuar no mercado de alumínio com responsabilidade, qualidade e pontualidade na busca da melhor solução para todos.

Visão

Ser referência em qualidade e atendimento criando cada vez mais oportunidades de negócio.

Valores

Flexibilidade, Honestidade, Inovação e Responsabilidade.



Linha de Acabamento Madeira por Sublimação.

O processo de Sublimação tem a finalidade de agregar aos Perfis de Alumínio, um acabamento decorativo semelhante à madeira. Assim, aumentamos a durabilidade e resistência do Alumínio e combinamos com a elegância decorativa da madeira. Essa combinação representa mais sustentabilidade e redução da degradação ambiental.

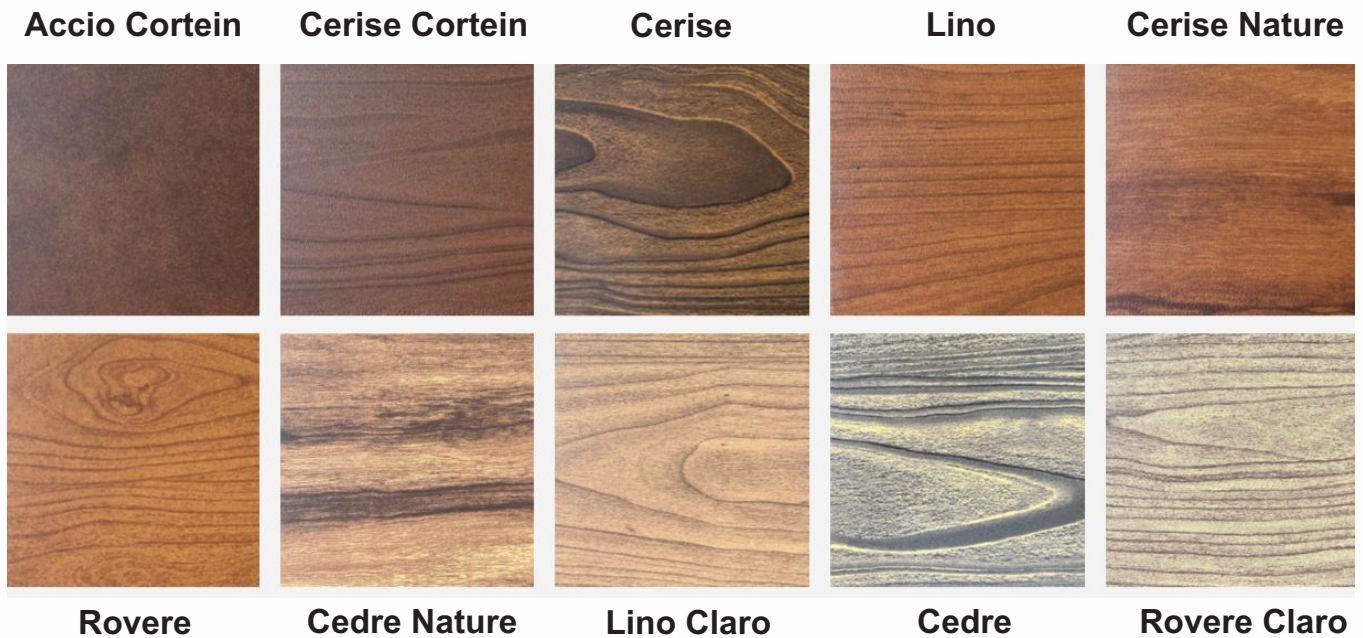

Toda a linha sublimada com 10 anos de garantia.

TIPOLOGIAS

Pág. 07

ÍNDICE DE PERFIS

Pág. 09

PERFIS

Pág.11

USINAGENS

Pág. 40

MONTAGENS

Pág. 48

Determinação da pressão de ensaio que deve ser aplicada na esquadria conforme a sua localização.

A - Identifique na figura abaixo a região do País onde está localizada a sua edificação. (Ex: Gravatal - Região V)

Figura 1 - Isopletas da velocidade básica. Fonte: ABNT NBR 6123

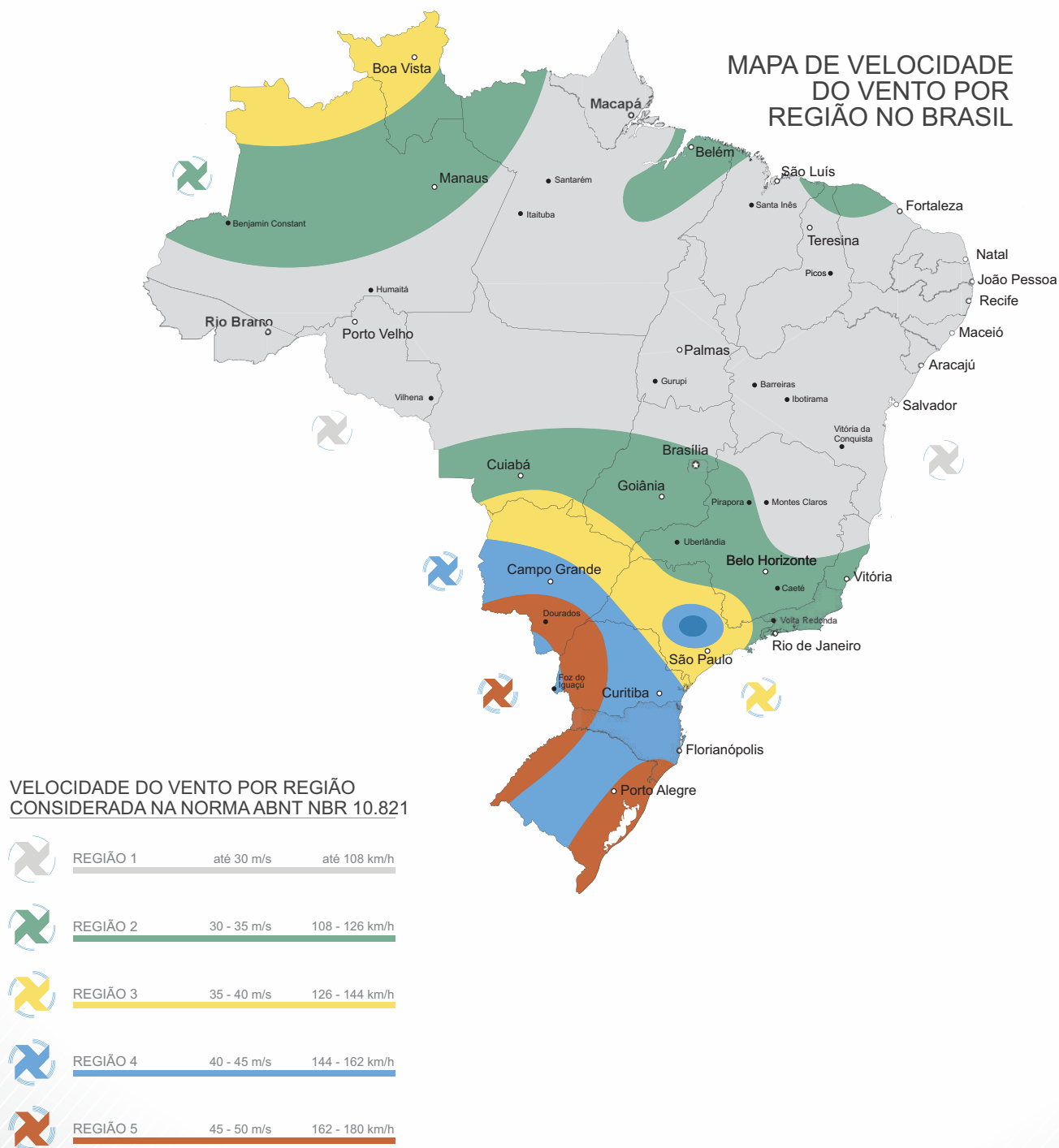

B - Com a Região encontrada no gráfico de isoplefas (Figura 1), verifique na tabela abaixo a Pressão de Ensaio de acordo com a altura ou quantidade de pavimentos da sua edificação;

Quantidade de Pavimentos	Altura Máxima	Região do País	Pressão de ensaio Pe, em (Pa) Positiva e negativa $Pe = Pp \times 1,2$	Pressão de segurança Ps, em (Pa) Positiva e negativa $Pe = Pp \times 1,5$	Pressão de água Pa, em (Pa) $Pe = Pp \times 1,2$
02	6 m	I	350	520	60
		II	470	700	80
		III	610	920	100
		IV	770	1160	130
		V	950	1430	160
05	15 m	I	420	640	70
		II	580	860	100
		III	750	1130	130
		IV	950	1430	160
		V	1180	1760	200
10	30 m	I	500	750	80
		II	680	1030	110
		III	890	1340	150
		IV	1130	1700	190
		V	1400	2090	230
20	60 m	I	600	900	100
		II	815	1220	140
		III	1060	1600	180
		IV	1350	2020	220
		V	1660	2500	280
30	90 m	I	660	980	110
		II	890	1340	150
		III	1170	1750	200
		IV	1480	2210	250
		V	1820	2730	300

C - Com a Pressão de Ensaio definida, é possível verificar nas páginas dos Diagramas de Desempenho, as medidas máximas de largura e altura para as tipologias existentes em sua edificação. Para isso ligue o eixo da largura ou altura na curva referente à pressão de ensaio requerida e verifique a dimensão máxima correspondente.

Notas:

* Nos gráficos de desempenho, foram considerados os valores de Pressão de Ensaio e Pressão de Segurança de acordo com a norma **ABNT NBR 10821**. Para edifícios com especificações, localização, necessidades e exigências especiais de utilização, deve-se consultar a **ABNT NBR 6123** para a determinação da pressão de projeto (Pp) e pressão de ensaio (Pe), prevalecendo como mínimos os valores acima.

* A espessura mínima dos vidros deve ser calculada utilizando-se o valor da Pressão de Segurança requerida para a esquadria (para maiores informações consultar a **ABNT NBR 10821** parte 2 e 3).

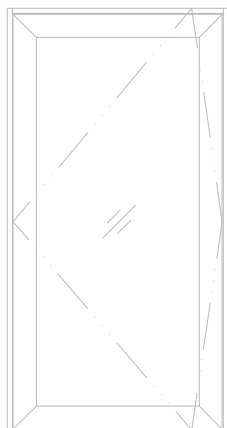

Porta Pivotante 1 Folha
Com Vidro

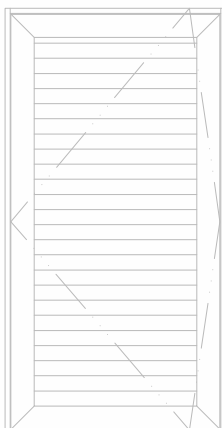

Porta Pivotante 1 Folha
Com Lambri

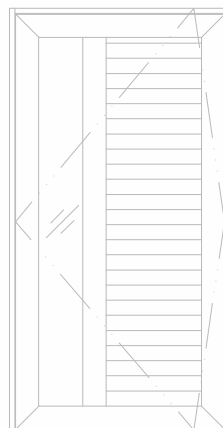

Porta Pivotante 1 Folha
Com Vidro e Lambri

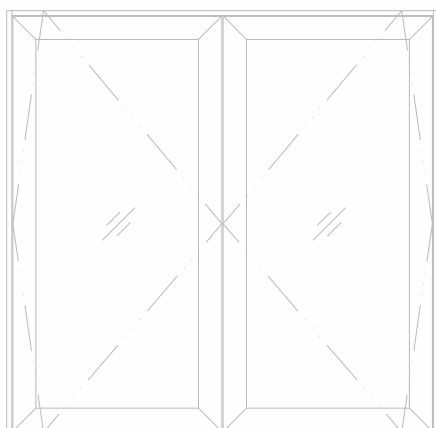

Porta Pivotante 2 Folhas
Com Vidro

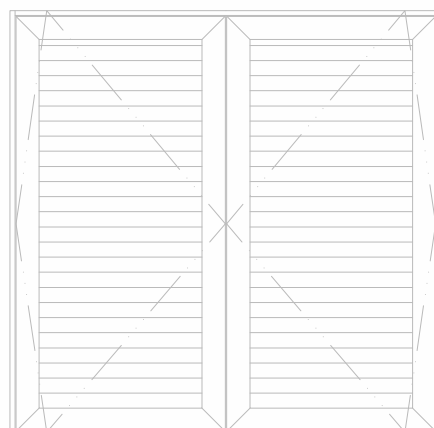

Porta Pivotante 2 Folhas
Com Lambri

INFORMAÇÕES IMPORTANTES

- * Todos os itens que compõem a tipologia devem ser conferidos.
- * Os projetos servem para orientação, não dispensando que seja conferido por um Técnico ou responsável da empresa, a fim de garantir a perfeita execução das tipologias.
 - * Qualquer item pode ser substituído sem aviso prévio.
- * Este projeto é propriedade da PERFISUD. É vedada Cópia, reprodução e fabricação dos detalhes totais ou parciais, sem autorização da empresa.

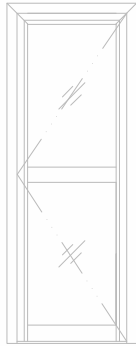

Porta De Giro 1 Folha
Com Vidro

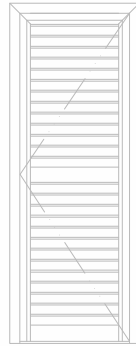

Porta De Giro 1 Folha
Com Lambri

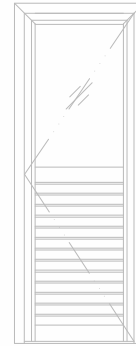

Porta De Giro 1 Folha
Com Vidro e Lambri

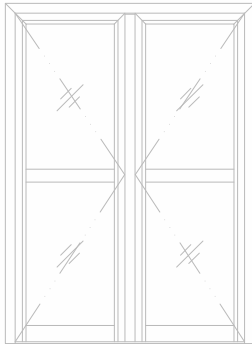

Porta De Giro 2 Folhas
Com Vidro

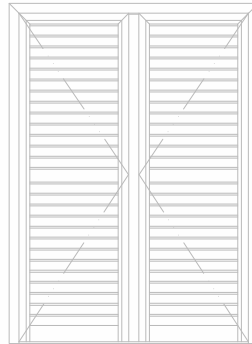

Porta De Giro 2 Folhas
Com Lambri

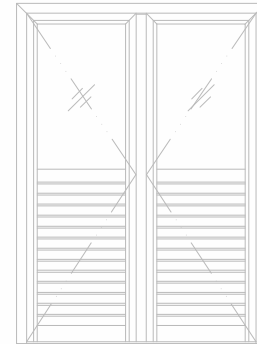

Porta De Giro 2 Folhas
Com Vidro e Lambri

INFORMAÇÕES IMPORTANTES

- * Todos os itens que compõem a tipologia devem ser conferidos.
- * Os projetos servem para orientação, não dispensando que seja conferido por um Técnico ou responsável da empresa, a fim de garantir a perfeita execução das tipologias.
 - * Qualquer item pode ser substituído sem aviso prévio.
- * Este projeto é propriedade da PERFISUD. É vedada Cópia, reprodução e fabricação dos detalhes totais ou parciais, sem autorização da empresa.

Código	Aplicação	Linha	Página
25-026	Travessa 40 mm	Linha 25	16
25-059	Marco Tubular	Linha 25	15
25-508	Travessa 56 mm	Linha 25	16
25-540	Marco Tubular	Linha 25	15
25-542	Folha Perimetral	Linha 25	15
25-543	Folha Perimetral	Linha 25	15
25-544	Folha Perimetral - Veneziana	Linha 25	15
25-548	Batente	Linha 25 / Versatic 25	17
30-023	Marco Tubular	Linha 30	20
30-034	Batente	Linha 30	20
30-035	Marco Tubular	Linha 30	20
42-007	Travessa 100 mm	Linha 42	31
42-014	Batente	Linha 42	29
42-032	Folha Perimetral	Linha 42	30
42-035	Folha Perimetral	Linha 42	30
42-050	Folha Da Porta	Linha 42	30
A-144	Folha Perimetral - Veneziana	Linha 30	22
BAR-4037	Cunha De Ligação 45°	Contramarcos e Conexões	11
BG-001	Baguete Vertical e Horizontal	Linha 25	16
BG-013	Baguete Vertical e Horizontal	Linha 30	23
BG-037	Baguete Vertical e Horizontal	Linha 42	31
BG-057	Baguete Vertical e Horizontal	Deluxe 32	27
CL-006	Cantoneira De Ligação 45°	Contramarcos e Conexões	11
CL-011	Cunha De Ligação 45°	Contramarcos e Conexões	11
CM-060	Contramarco	Contramarcos e Conexões	12
CM-1002	Contramarco	Contramarcos e Conexões	12
CM-175	Chumbador	Contramarcos e Conexões	12
CX-642	Veneziana	Lambris e Venezianas	38
DV-013	Acabamento Ripado	Linha 32	26
DS-036	Porta Veneziana	Linha 25	16
L-579	Cantoneira De Ligação 45°	Contramarcos e Conexões	11
ME-075	Folha Perimtral	Linha 30	23
MN-014	Arremate / Vista	Arremates	13
MP-3348	Arremate / Vista	Arremates	13
MP-346	Arremate / Vista	Arremates	14
MP-347	Arremate / Vista	Arremates	13
MP-347S	Arremate / Vista	Arremates	13
MP-348	Arremate / Vista	Arremates	13
MP-349	Arremate / Vista	Arremates	14
MP-350	Arremate / Vista	Arremates	14
P-153	Travessa 40mm	Linha 25	16
P-264	Folha Perimetral	Linha 30	22
P-272	Marco Tubular	Linha 30	20
P-280	Marco Tubular	Linha 42	29
PEI-009	Marco Perimetral	Portas Pivotantes	19
PEI-010	Lambri	Lambris e Venezianas	24
PEI-011	Folha Perimetral	Portas Pivotantes	21
PEI-012	Marco Lateral	Portas Pivotantes	19
PEI-013	Marco Superior	Portas Pivotantes	19
PEI-014	Friso	Lambris e Venezianas	24
PEX-002	Arremate / Vista	Arremates	14

Código	Aplicação	Linha	Página
PLB-061	Lambri Liso	Lambris e Venezianas	33
PLB-061L	Lambri Liso Leve	Lambris e Venezianas	33
PLB-062	Friso	Lambris e Venezianas	33
PLB-070	Lambri Negativo	Lambris e Venezianas	34
PLB-075	Lambri Ripado	Lambris e Venezianas	33
PLB-080	Lambri Liso	Lambris e Venezianas	33
PLB-085	Lambri Ripado	Lambris e Venezianas	33
PLB-208	Lambri	Lambris e Venezianas	34
PLG-027	Baguete Veneziana	Deluxe 32	27
PLG-043	Folha Perimetral	Deluxe 32	25
PLG-055	Travessa 64 mm	Deluxe 32	26
PLG-056	Marco	Deluxe 32	25
PLG-238	Redutor	Deluxe 32	26
PLG-239	Folha Perimetral	Deluxe 32	25
PPO-001	Lambri	Lambris e Venezianas	24
PPO-002	Folha Perimetral	Portas Pivotantes	13
PPO-003	Folha Perimetral	Portas Pivotantes	20
PPO-004	Travessa 75 mm	Portas Pivotantes	21
PPO-005	Folha Perimetral	Portas Pivotantes	20
PPO-006	Lambri	Lambris e Venezianas	14
PPO-007	Folha Perimetral Pivotante	Portas Pivotantes	13
PSU-102	Baguete Vertical e Horizontal	Versatic 25	18
PSU-108	Baguete Veneziana	Versatic 25	18
PSU-110	Folha Superior e Inferior	Versatic 25	17
PSU-111	Folha	Versatic 25	17
PSU-227	Travessa 57 mm	Versatic 25	18
PSU-241	Folha Perimetral S/ Baguete	Versatic 25	18
PSU-279	Marco Tubular	Versatic 25	17
PSU-350	Folha Perimetral - Lambri	Versatic 25	18
VZ-006	Veneziana	Lambris e Venezianas	27
VZ-006VT	Veneziana Ventilada	Lambris e Venezianas	27
VZ-023	Veneziana	Lambris e Venezianas	26
VZ-023VT	Veneziana Ventilada	Lambris e Venezianas	26
VZ-024	Veneziana	Lambris e Venezianas	26
VZ-024VT	Veneziana Ventilada	Lambris e Venezianas	26
VZ-080	Veneziana	Lambris e Venezianas	27
VZ-080VT	Veneziana Ventilada	Lambris e Venezianas	27
VZ-082	Veneziana	Lambris e Venezianas	29
VZ-082VT	Veneziana Ventilada	Lambris e Venezianas	29
VZ-106	Veneziana	Lambris e Venezianas	28
VZ-106VT	Veneziana Ventilada	Lambris e Venezianas	28
Y-1174	Contramarco	Contramarcos e Conexões	09
Y-145	Veneziana	Lambris e Venezianas	30
Y-163	Veneziana	Lambris e Venezianas	29
Z-284	Veneziana	Lambris e Venezianas	30

CL-011	Cunha de Ligação 45°
Peso (Kg/m)	Perfis De Encaixe:
0,308	

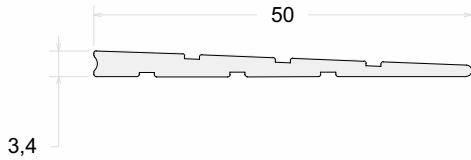

CL-006	Cantoneira de Ligação 45°
Peso (Kg/m)	Perfis De Encaixe:
1,041	

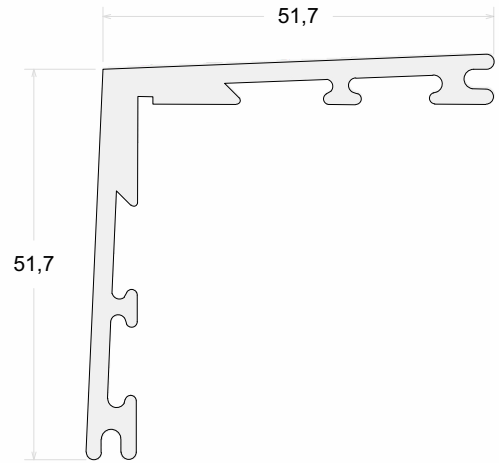

BAR-4037	Cunha de Ligação 45°
Peso (Kg/m)	Perfis De Encaixe:
0,471	

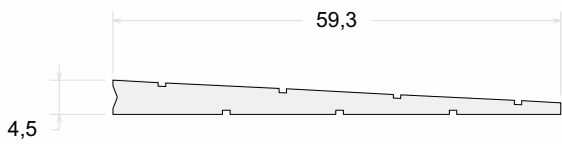

L-579	Cantoneira de Ligação 45°
Peso (Kg/m)	Perfis De Encaixe:
1,014	

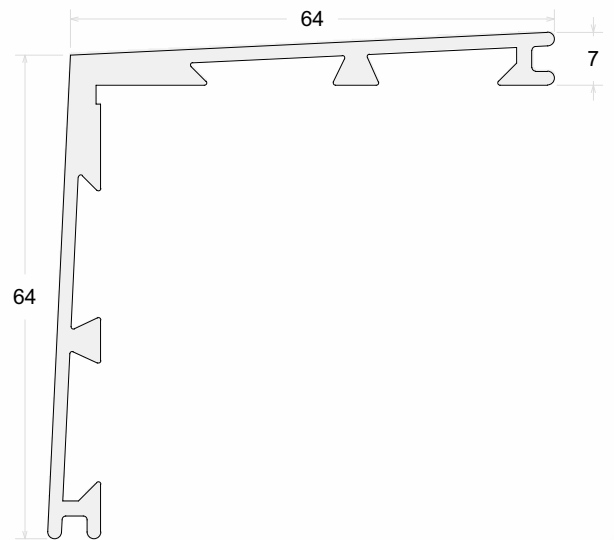

CM-1002	Contramarco
Peso (Kg/m)	Perfis De Encaixe:
0,263	

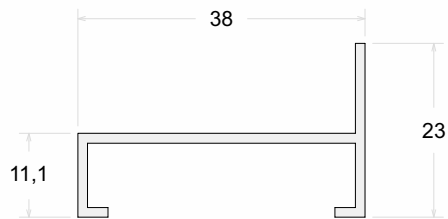

CM-060	Contramarco
Peso (Kg/m)	Perfis De Encaixe:
0,222	

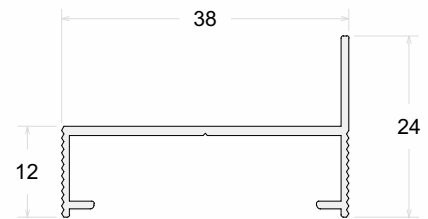

Y-1174	Contramarco
Peso (Kg/m)	Perfis De Encaixe:
0,369	



CM-063	Contramarco
Peso (Kg/m)	Perfis De Encaixe:
0,154	

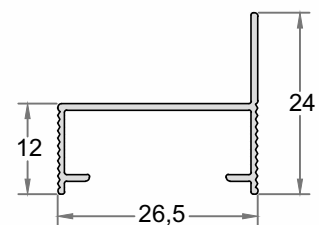

CM-175	Chumbador do Contramarco
Peso (Kg/m)	Perfis De Encaixe:
0,589	

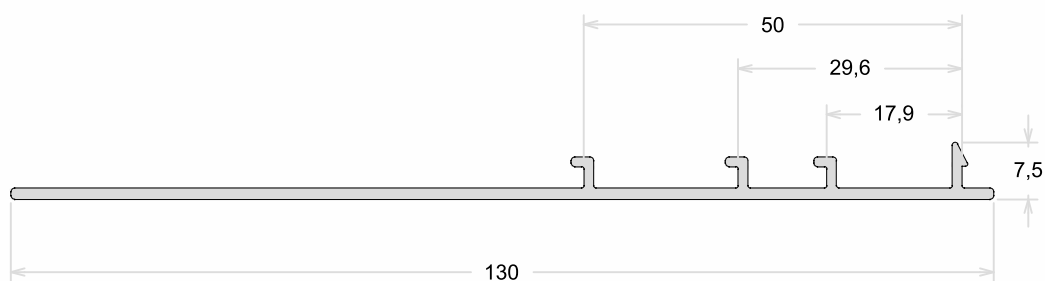

Medida de uso 20 mm

MP-348	Arremate / Vista Interna
Peso (Kg/m)	Perfis De Encaixe:
0,174	

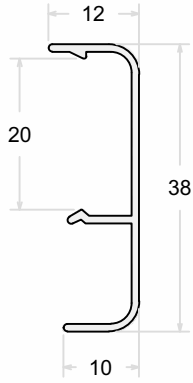

MN-014	Arremate / Vista Interna
Peso (Kg/m)	Perfis De Encaixe:
0,201	

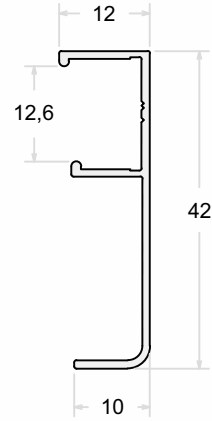

MP-347	Arremate / Vista Interna
Peso (Kg/m)	Perfis De Encaixe:
0,162	

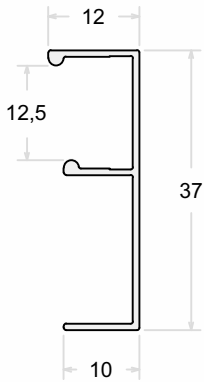

MP-347S	Arremate / Vista Interna
Peso (Kg/m)	Perfis De Encaixe:
0,217	

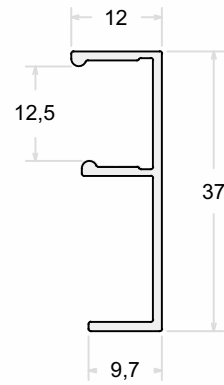

MP-3348	Arremate / Vista Interna
Peso (Kg/m)	Perfis De Encaixe:
0,206	

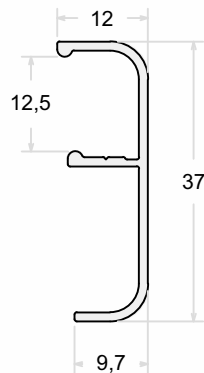

MP-350	Arremate / Vista Interna
Peso (Kg/m)	Perfis De Encaixe:
0,268	

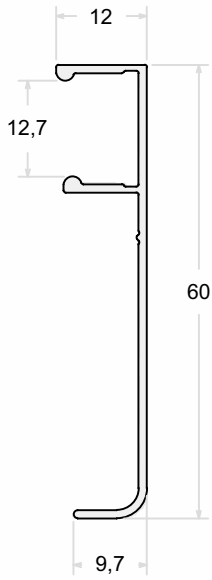

PEX-002	Arremate / Rodapé
Peso (Kg/m)	Perfis De Encaixe:
0,332	

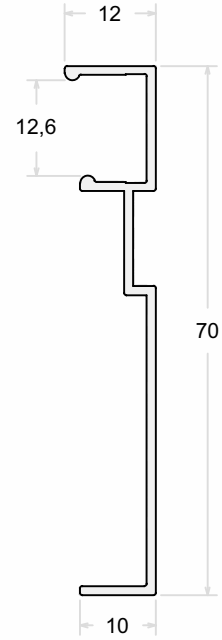

MP-346	Arremate / Vista Interna
Peso (Kg/m)	Perfis De Encaixe:
0,302	

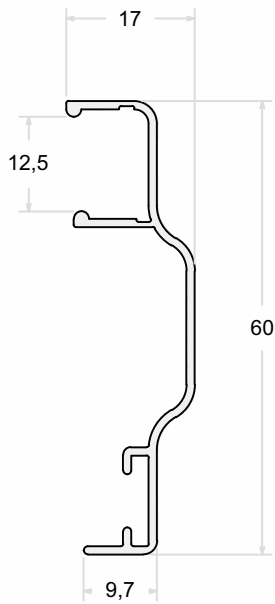

MP-349	Arremate / Vista Interna
Peso (Kg/m)	Perfis De Encaixe:
0,298	

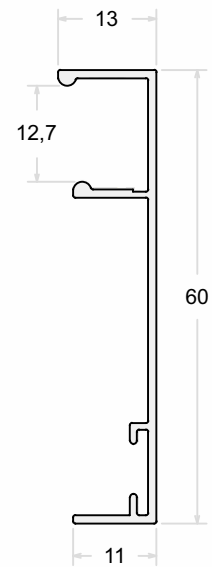

25-540

Marco Porta de Giro

Peso
(Kg/m)

Perfis De Encaixe:

0,440

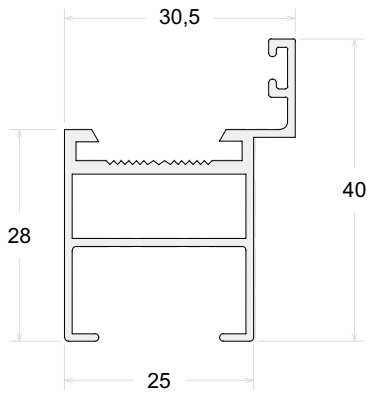

25-059

Marco Porta de Giro

Peso
(Kg/m)

Perfis De Encaixe:

0,390

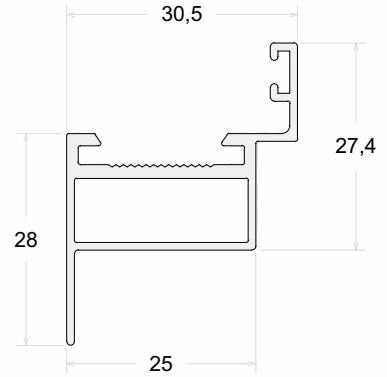

25-542

Folha Perimetral

Peso
(Kg/m)

Perfis De Encaixe: BG-001

0,542

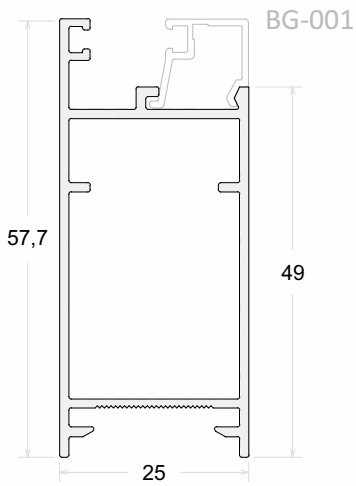

25-544

Folha Perimetral - Veneziana

Peso
(Kg/m)

Perfis De Encaixe:

0,597

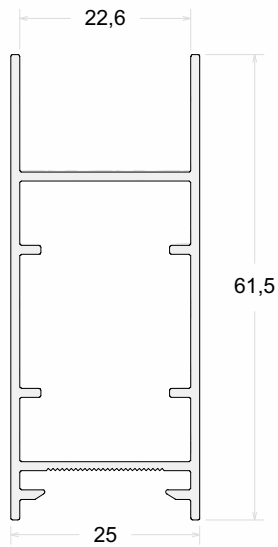

25-543

Folha Perimetral

Peso
(Kg/m)

Perfis De Encaixe: BG-001

0,728

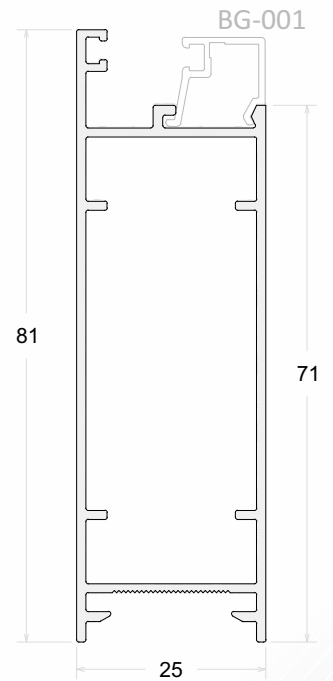

25-026	Travessa 40 mm
Peso (Kg/m)	Perfis De Encaixe:
0,474	

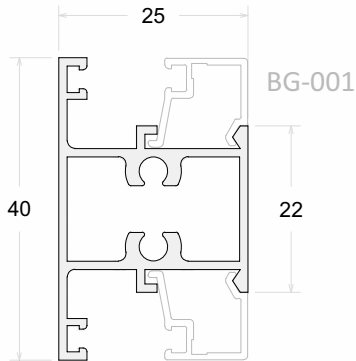

25-508	Travessa 56 mm
Peso (Kg/m)	Perfis De Encaixe:
0,594	

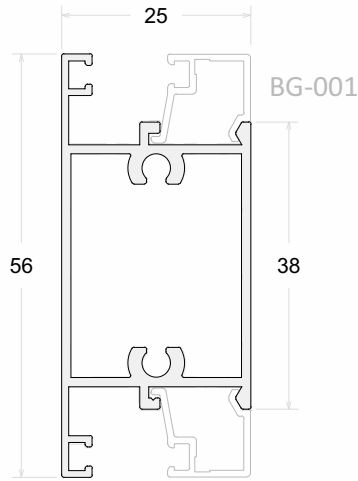

P-153	Travessa 40 mm
Peso (Kg/m)	Perfis De Encaixe:
0,529	

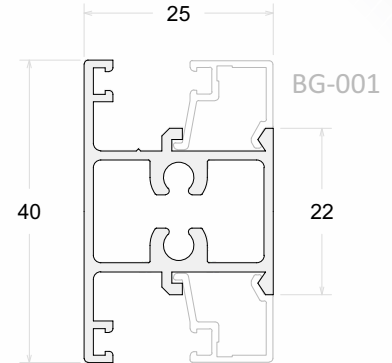

DS-036	Porta Veneziana
Peso (Kg/m)	Perfis De Encaixe:
0,152	

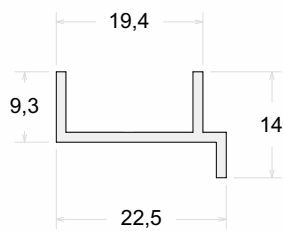

BG-001	Baguete Vertical e Horizontal
Peso (Kg/m)	Perfis De Encaixe:
0,091	

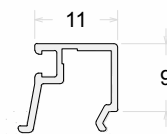

PSU-203	Baguete
Peso (Kg/m)	Perfis De Encaixe:
0,135	

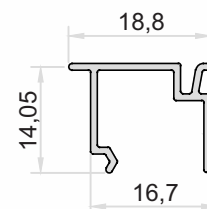

PSU-279	Marco Porta de Giro
Peso (Kg/m)	Perfis De Encaixe:
0,507	

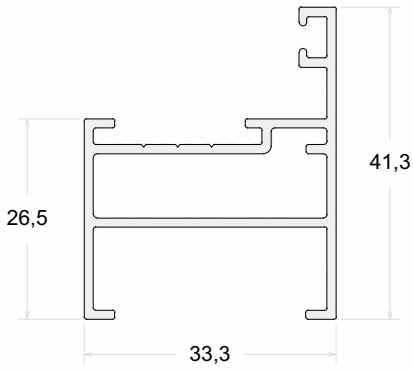

25-548	Batente Porta de Giro
Peso (Kg/m)	Perfis De Encaixe:
0,221	

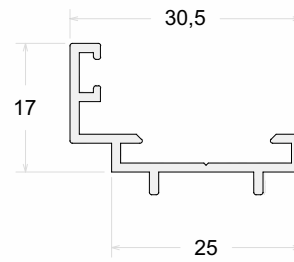

PSU-110	Folha Superior e Inferior
Peso (Kg/m)	Perfis De Encaixe:
0,514	

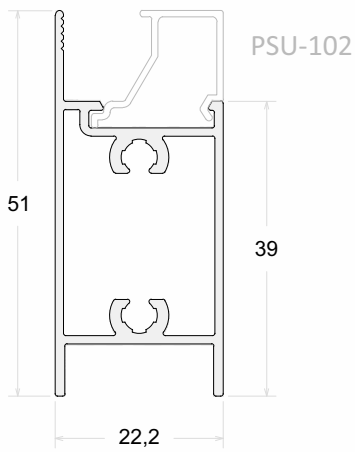

PSU-111	Folha Porta de Giro
Peso (Kg/m)	Perfis De Encaixe:
0,563	

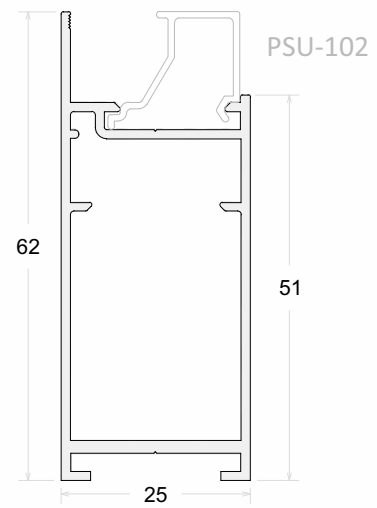

PSU-241 Folha Perimetral Sem Bagueete

Peso (Kg/m)
0,690

Perfis De Encaixe:

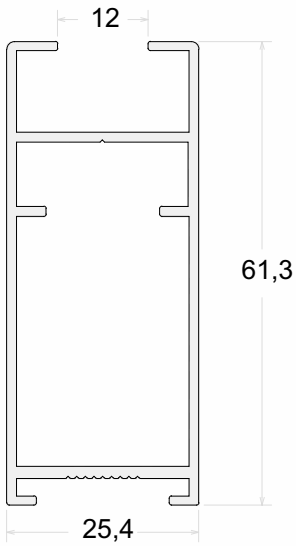

PSU-350 Folha Perimetral - Lambri

Peso (Kg/m)
0,768

Perfis De Encaixe:

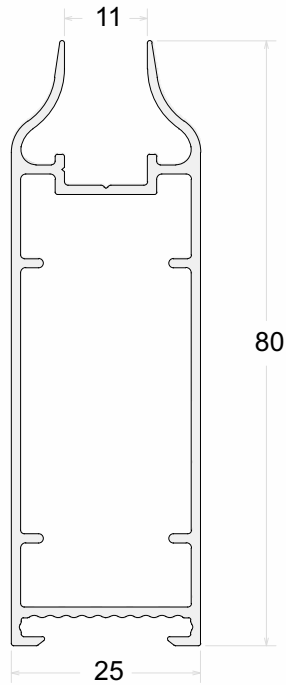

PSU-450 Montante 100mm Porta de Giro

Peso (Kg/m)
0,950

Perfis De Encaixe:

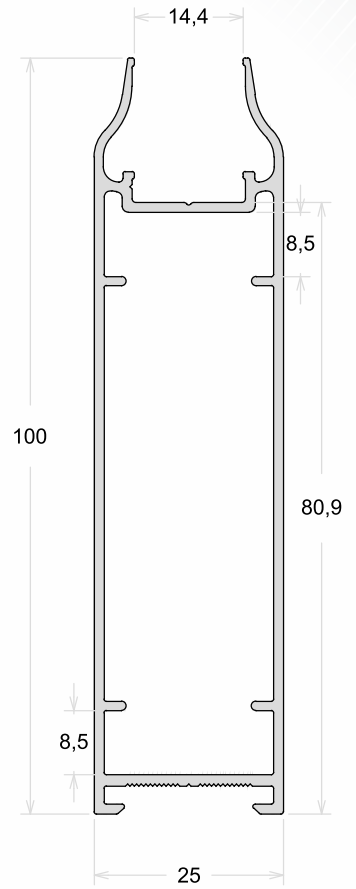

PSU-102 Bagueete Vertical e Horizontal

Peso (Kg/m)
0,105

Perfis De Encaixe:

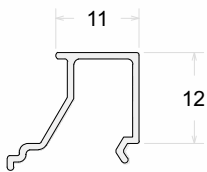

PSU-108 Complemento Veneziana

Peso (Kg/m)
0,140

Perfis De Encaixe:

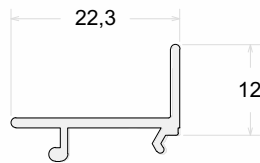

PSU-104 Bagueete Vertical e Horizontal

Peso (Kg/m)
0,109

Perfis De Encaixe:

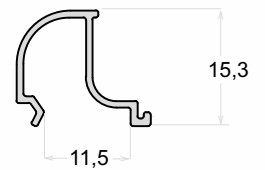

PSU-225 Folha Horizontal

Peso (Kg/m)
0,966

Perfis De Encaixe:

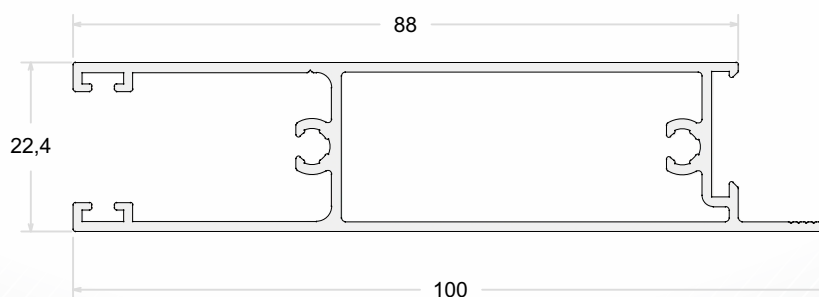

PEI-009	Marco Vertical e Horizontal
Peso (Kg/m)	Perfis De Encaixe:
0,315	

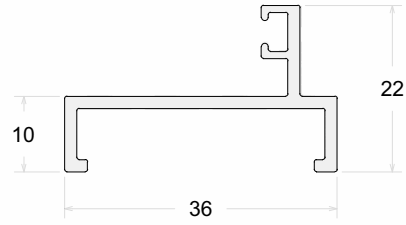

PEI-013	Marco Vertical e Horizontal
Peso (Kg/m)	Perfis De Encaixe:
0,897	

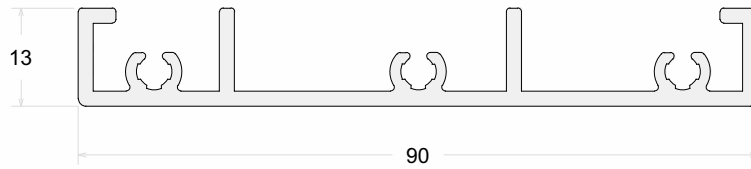

PEI-012	Marco Vertical e Horizontal
Peso (Kg/m)	Perfis De Encaixe:
0,830	

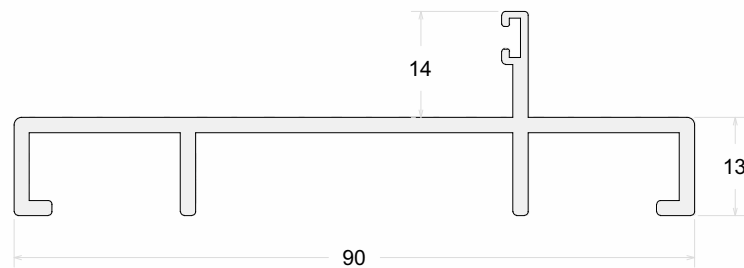

30-023 Marco Porta de Giro
Peso (Kg/m) 0,526
Perfis De Encaixe:

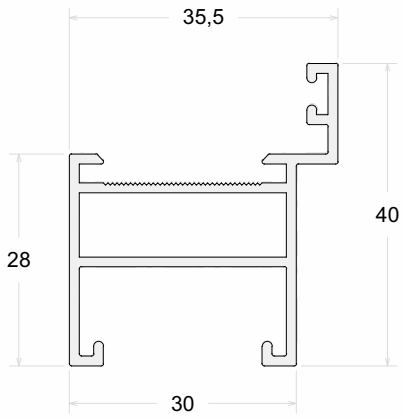

30-035 Marco Porta de Giro
Peso (Kg/m) 0,949
Perfis De Encaixe:

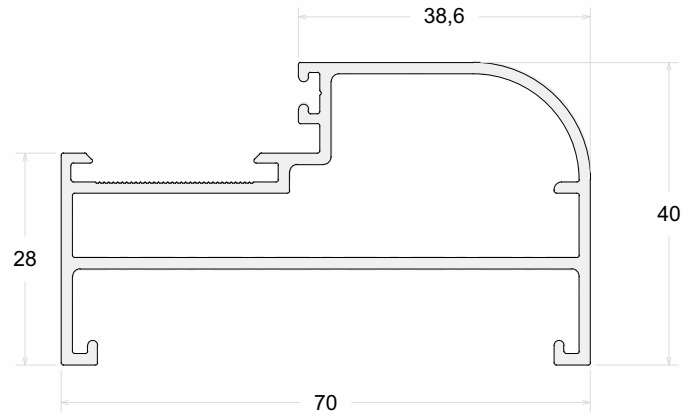

P-272 Marco Porta de Giro
Peso (Kg/m) 0,751
Perfis De Encaixe:

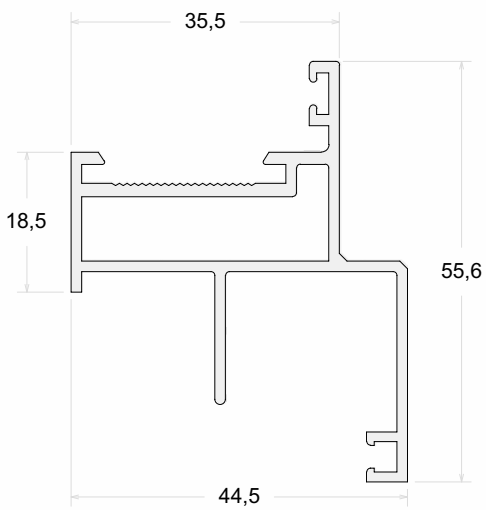

30-034 Batente Porta de Giro
Peso (Kg/m) 0,261
Perfis De Encaixe:

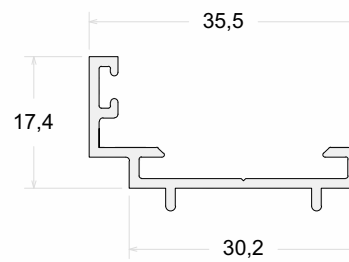

PEI-011	Folha Perimetral
Peso (Kg/m)	Perfis De Encaixe:
1,116	

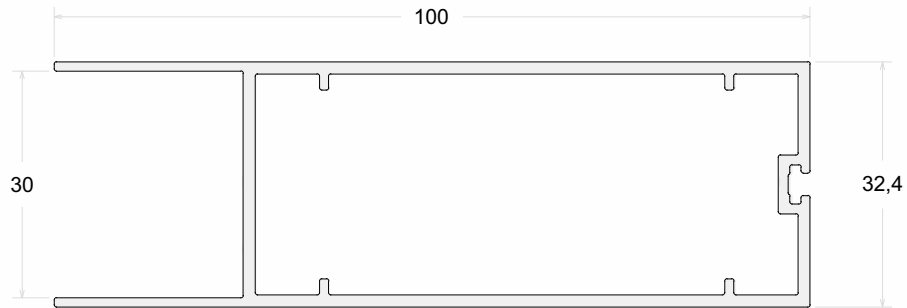

PPO-007	Folha Perimetral
Peso (Kg/m)	Perfis De Encaixe:
1,097	

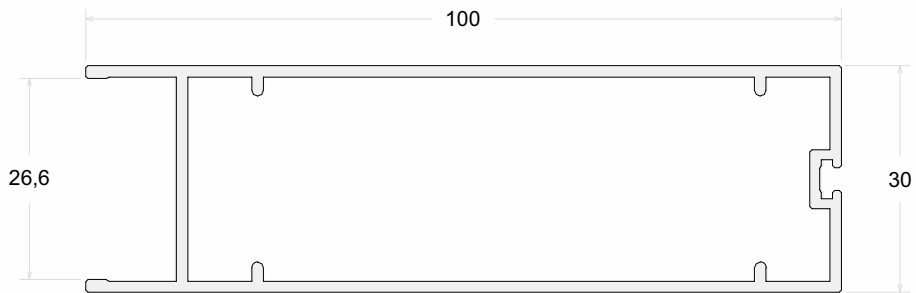

PPO-002	Marco Vertical e Horizontal
Peso (Kg/m)	Perfis De Encaixe:
1,088	

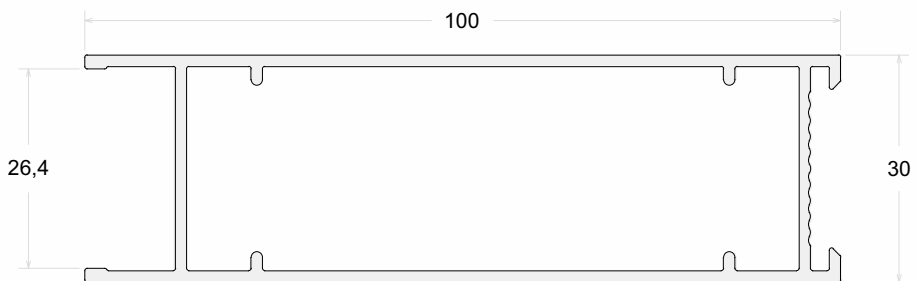

PPO-005	Folha Perimetral
Peso (Kg/m)	Perfis De Encaixe:
0,714	

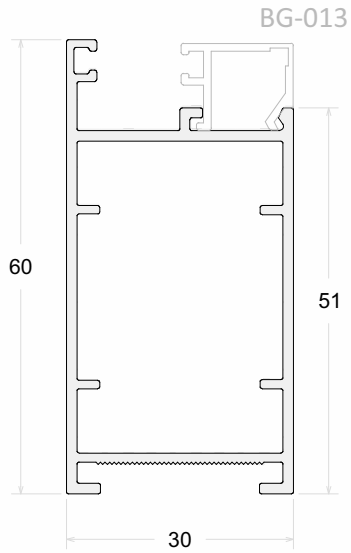

A-144	Folha Perimetral
Peso (Kg/m)	Perfis De Encaixe:
0,766	

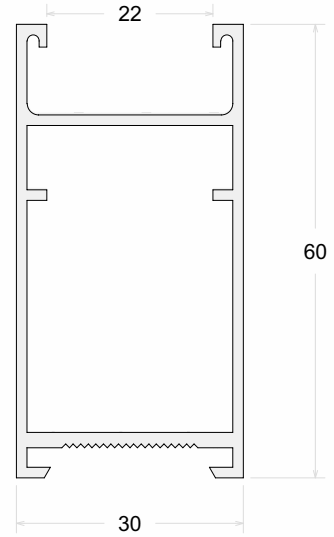

PPO-003	Folha Perimetral
Peso (Kg/m)	Perfis De Encaixe:
1,125	

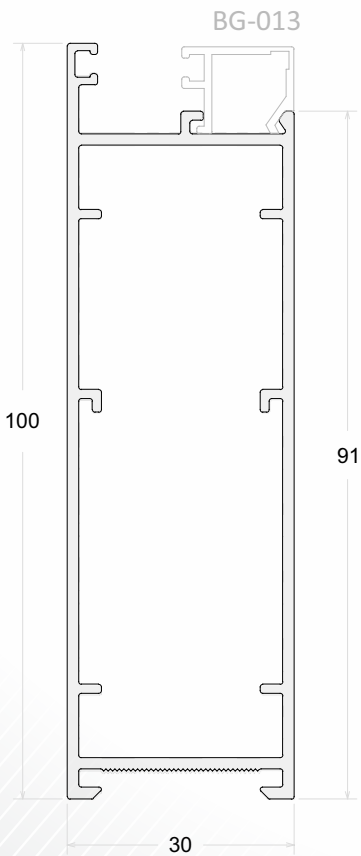

P-264	Folha Perimetral
Peso (Kg/m)	Perfis De Encaixe:
1,124	

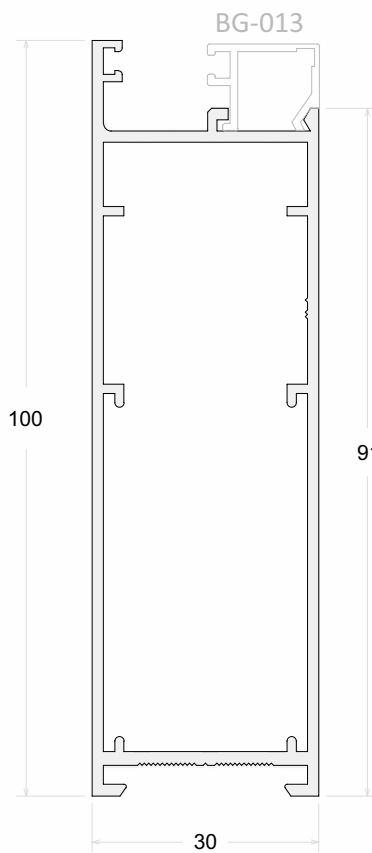

30-040	Montante 100mm Porta de Giro
Peso (Kg/m)	Perfis De Encaixe:
1,010	

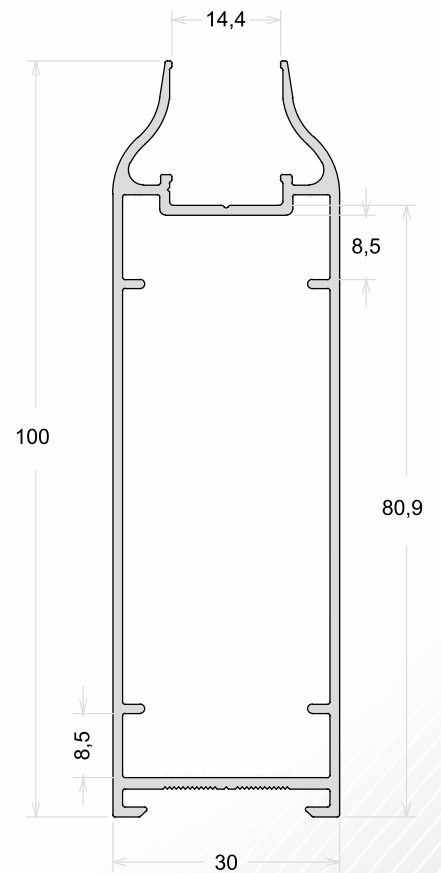

ME-075	Folha Perimetral
Peso (Kg/m)	Perfis De Encaixe:
0,978	

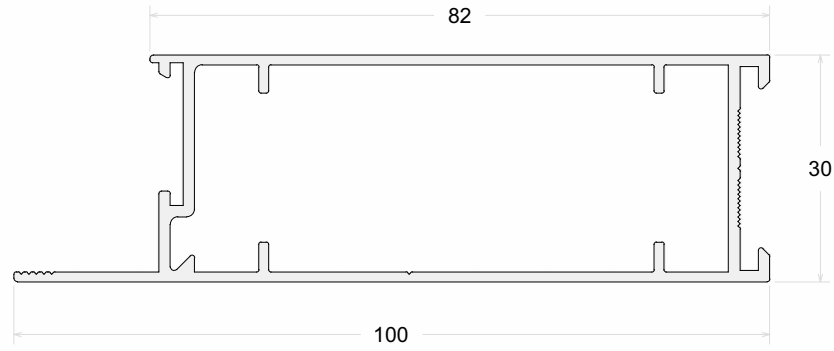

PPO-004	Travessa 75 mm
Peso (Kg/m)	Perfis De Encaixe:
0,807	

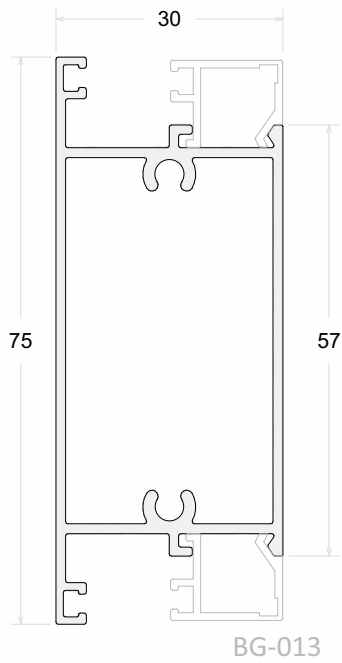

BG-013

BG-013	Baguete Vertical e Horizontal
Peso (Kg/m)	Perfis De Encaixe:
0,110	

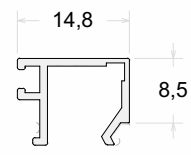

PEI-010	Lambri
Peso (Kg/m)	Perfis De Encaixe:
1,315	

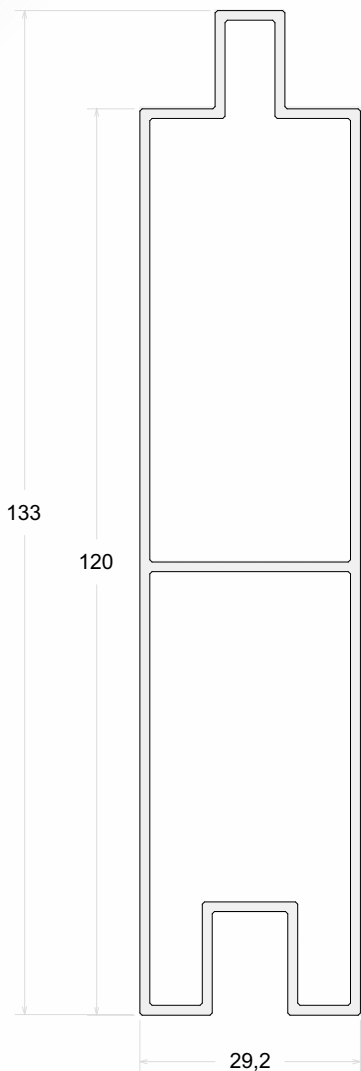

PPO-001	Lambri
Peso (Kg/m)	Perfis De Encaixe:
1,612	

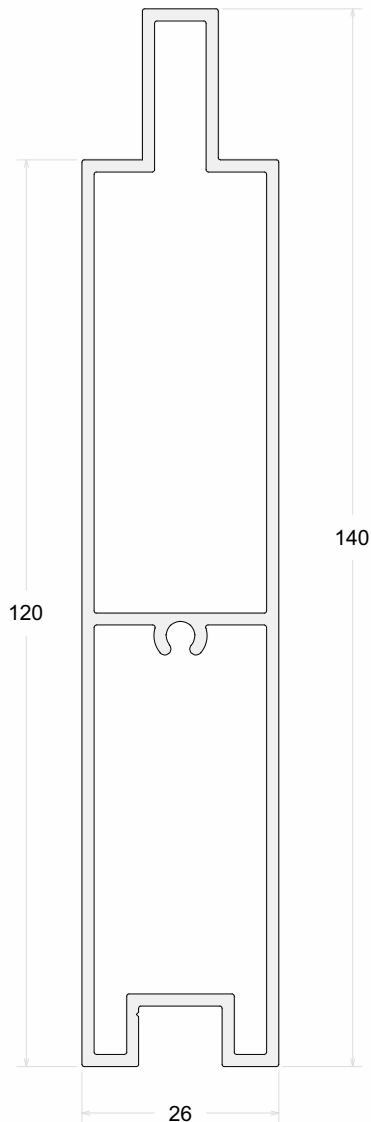

PPO-006	Lambri
Peso (Kg/m)	Perfis De Encaixe:
1,612	

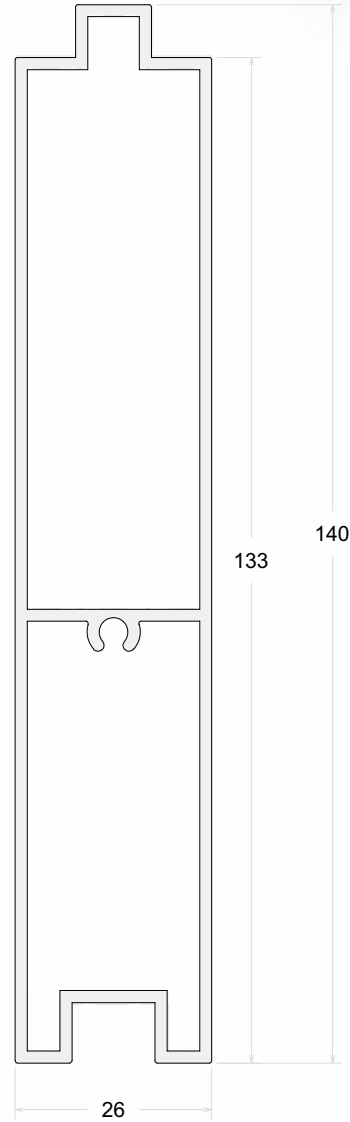

PEI-014	Friso Lambri
Peso (Kg/m)	Perfis De Encaixe:
0,495	

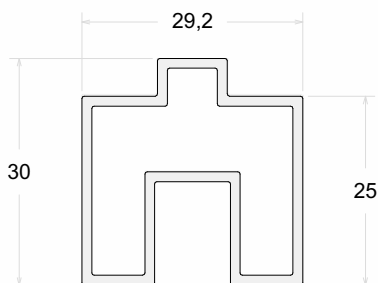

PLG-056	Marco Porta de Giro
Peso (Kg/m)	Perfis De Encaixe:
0,588	

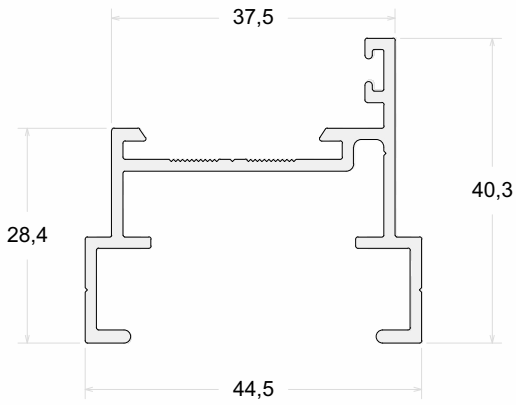

PLG-043	Folha Perimetral
Peso (Kg/m)	Perfis De Encaixe:
0,877	

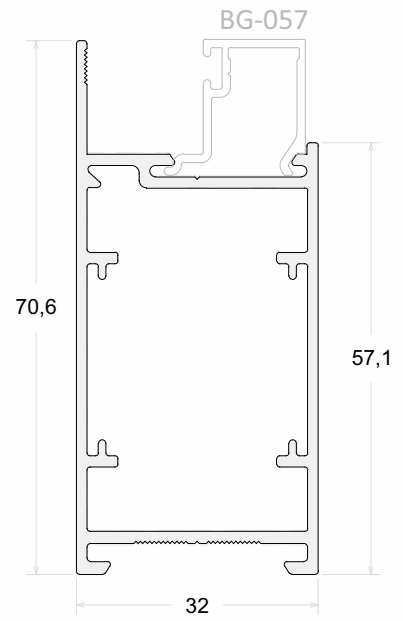

PLG-239	Folha Perimetral
Peso (Kg/m)	Perfis De Encaixe:
1,121	

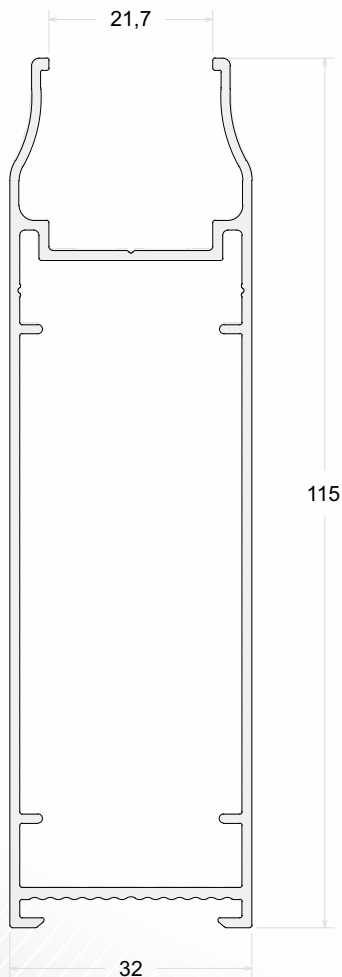

PLG-042	Folha Perimetral
Peso (Kg/m)	Perfis De Encaixe:
1,104	

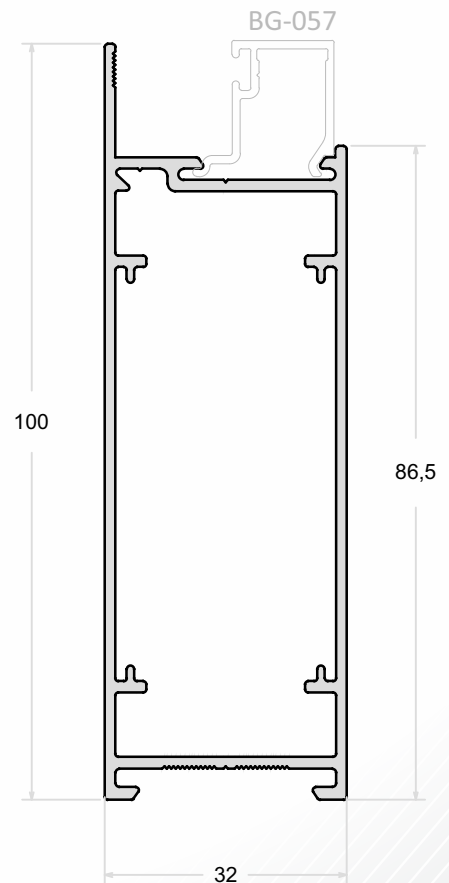

PLG-238

Redutor

Peso
(Kg/m)
0,273

Perfis De Encaixe

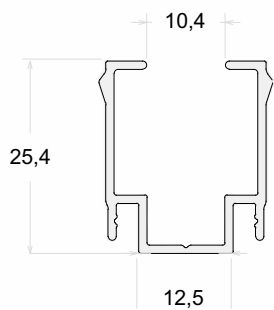

PLG-016

Batente Porta De Giro

Peso
(Kg/m)
0,316

Perfis De Encaixe:

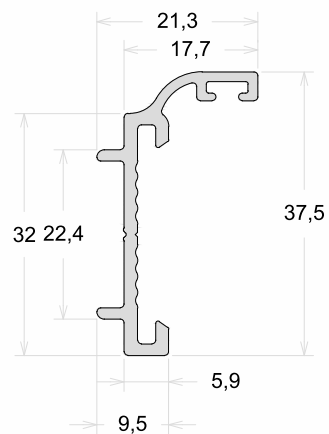

PLG-055

Travessa 64 mm

Peso
(Kg/m)
0,706

Perfis De Encaixe:

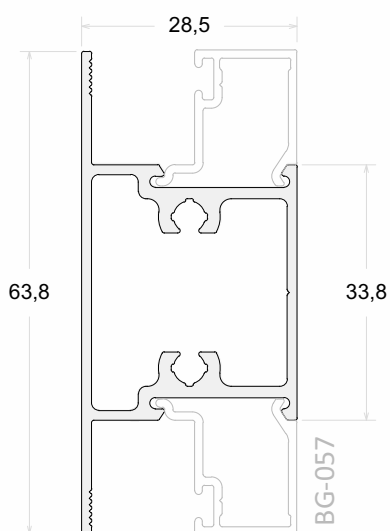

DV-013

Acabamento Ripado

Peso
(Kg/m)
0,318

Perfis De Encaixe:

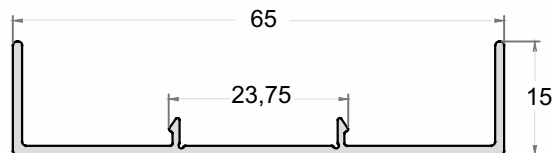

BG-057	Baguete Vertical e Horizontal
Peso (Kg/m)	Perfis De Encaixe:
0,170	

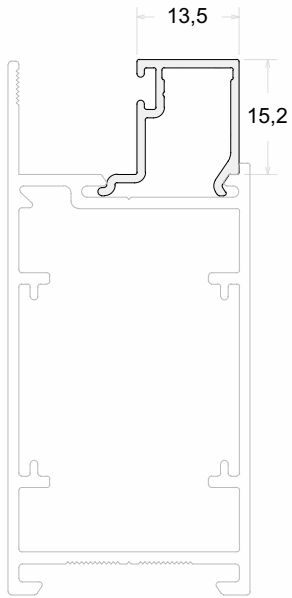

PLG-059	Baguete Vertical e Horizontal
Peso (Kg/m)	Perfis De Encaixe:
0,157	

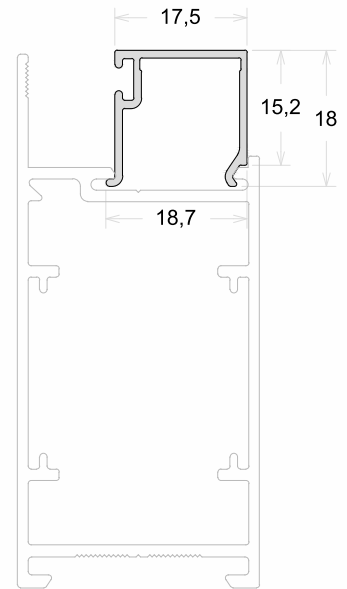

PLG-055	Travessa 64 mm
Peso (Kg/m)	Perfis De Encaixe:
0,706	

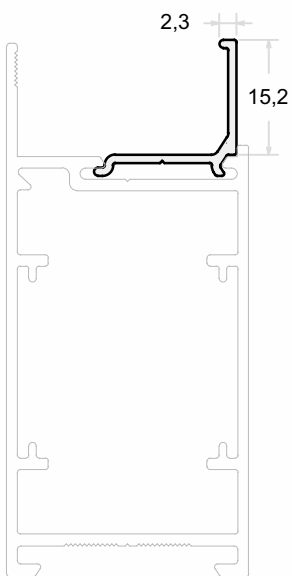

PLG-027	Baguete Veneziana
Peso (Kg/m)	Perfis De Encaixe:
0,146	

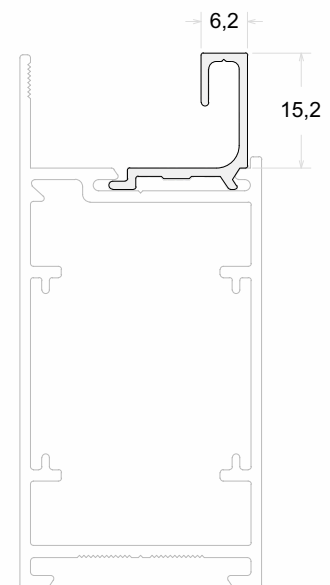

PPO-008	Arremate
Peso (Kg/m)	Perfis De Encaixe:
1,031	

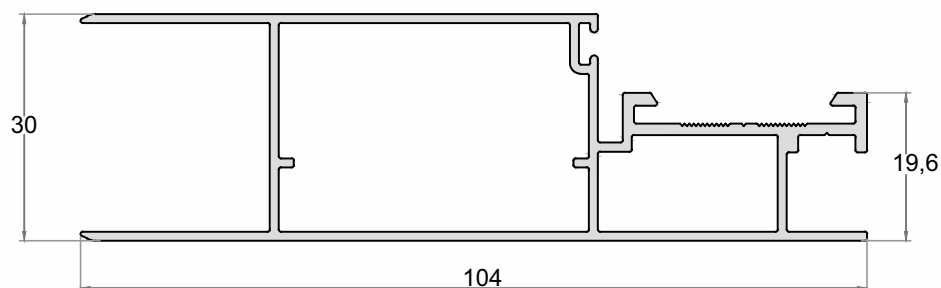

PPO-010	Arremate
Peso (Kg/m)	Perfis De Encaixe:
0,755	

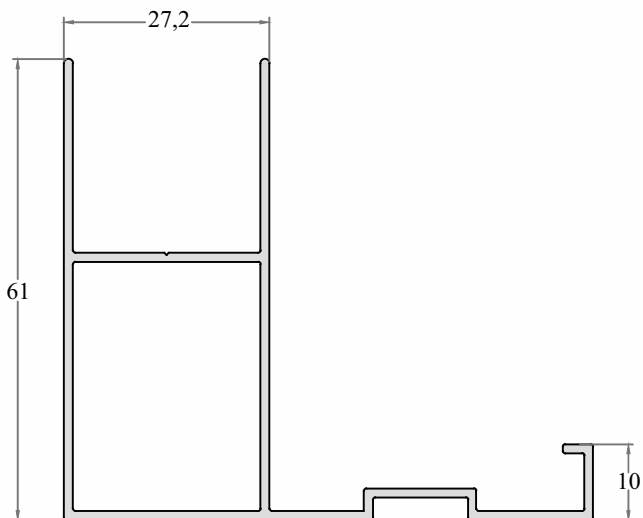

PPO-011	Arremate
Peso (Kg/m)	Perfis De Encaixe:
0,381	

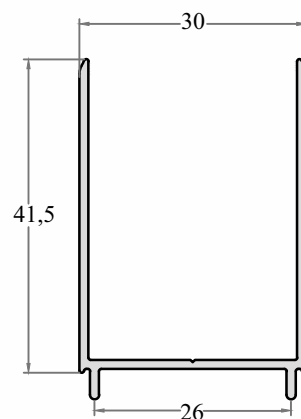

PPO-012	Arremate
Peso (Kg/m)	Perfis De Encaixe:
0,407	

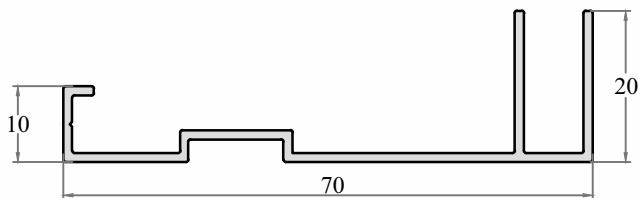

P-280	Marco
Peso (Kg/m)	Perfis De Encaixe:
0,816	

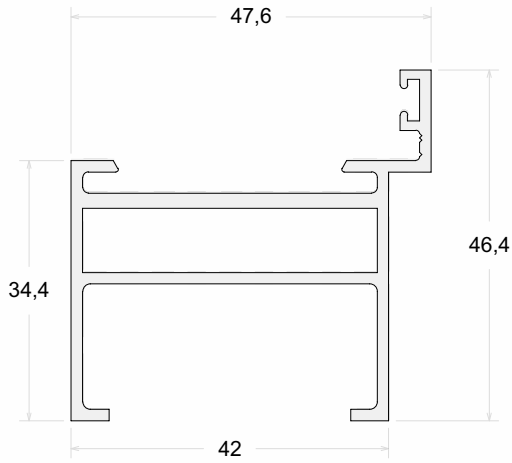

42-040	Batente Marco
Peso (Kg/m)	Perfis De Encaixe:
0,621	

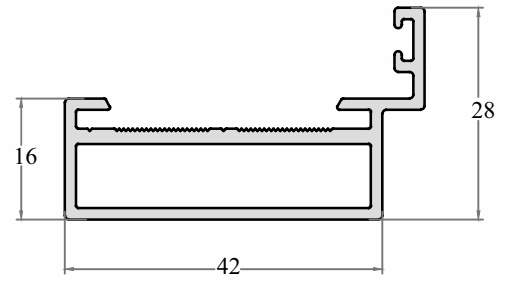

42-014	Batente
Peso (Kg/m)	Perfis De Encaixe:
0,374	

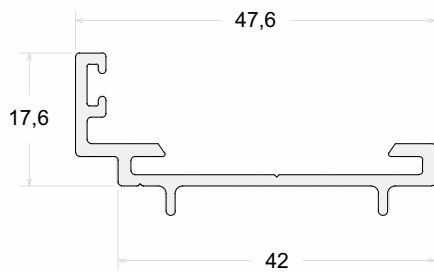

42-048	Click de Acabamento da Folha
Peso (Kg/m)	Perfis De Encaixe:
0,344	

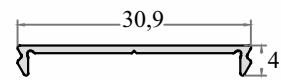

42-050	Folha da Porta
Peso (Kg/m)	Perfis De Encaixe:
2,052	

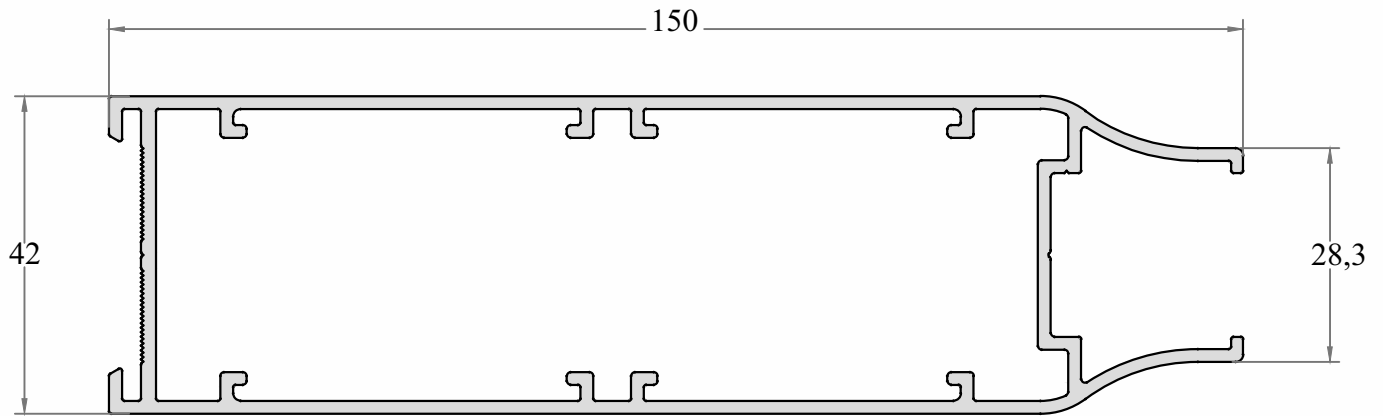

42-035	Folha Perimetral
Peso (Kg/m)	Perfis De Encaixe:
1,156	

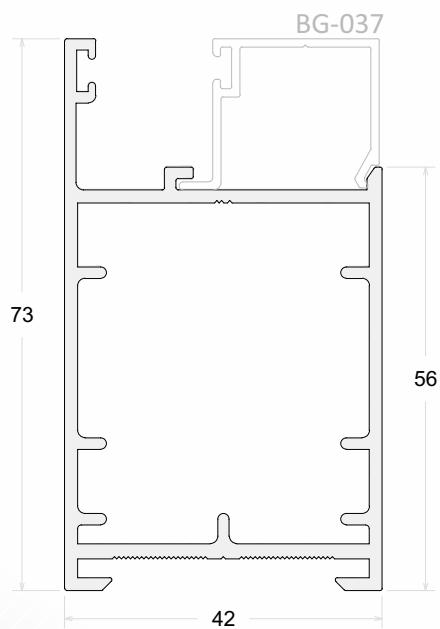

42-032	Folha Perimetral
Peso (Kg/m)	Perfis De Encaixe:
1,375	

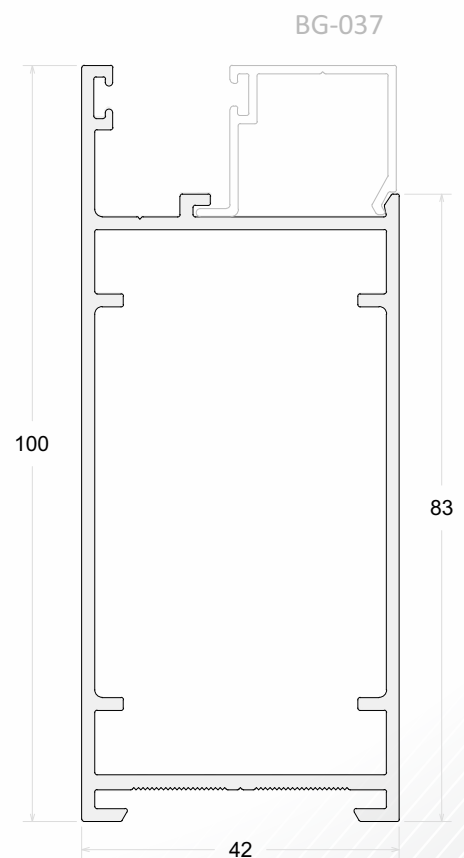

BG-037	Baguete Vertical e Horizontal
Peso (Kg/m)	Perfis De Encaixe:
0,208	

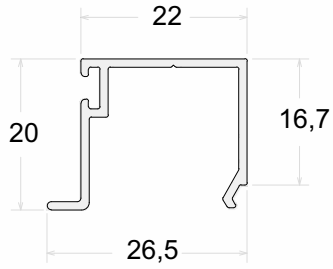

PLG-238	Redutor
Peso (Kg/m)	Perfis De Encaixe:
0,273	

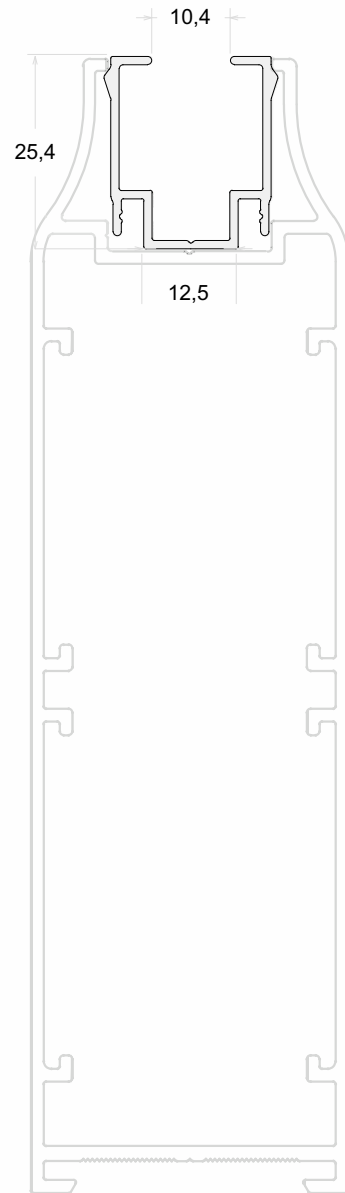

42-007	Travessa 100 mm
Peso (Kg/m)	Perfis De Encaixe:
1,331	

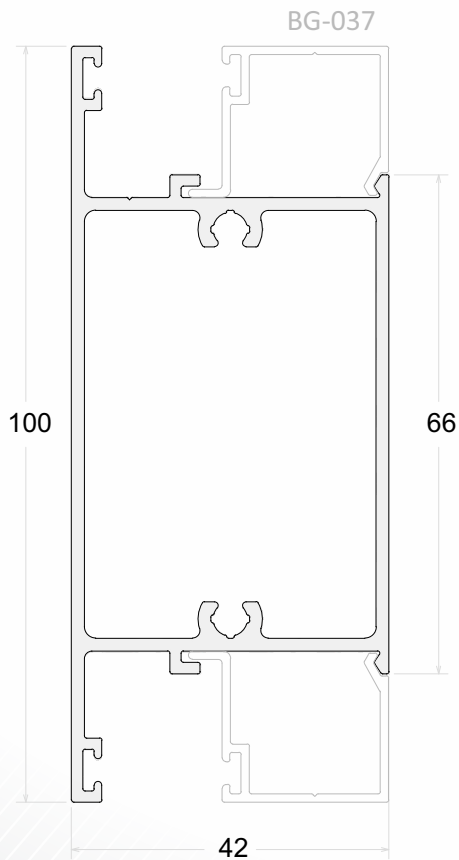

PLB-042	Lambri
Peso (Kg/m)	Perfis De Encaixe:
1,382	

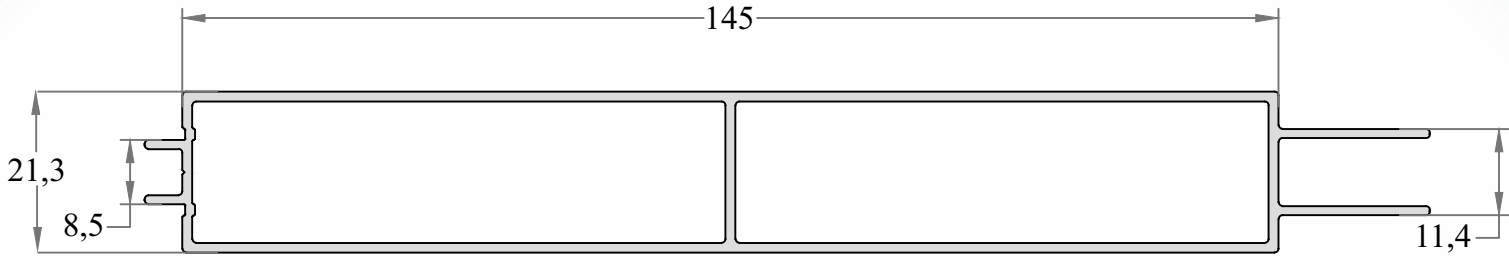

PLB-080	Lambri
Peso (Kg/m)	Perfis De Encaixe:
1,382	

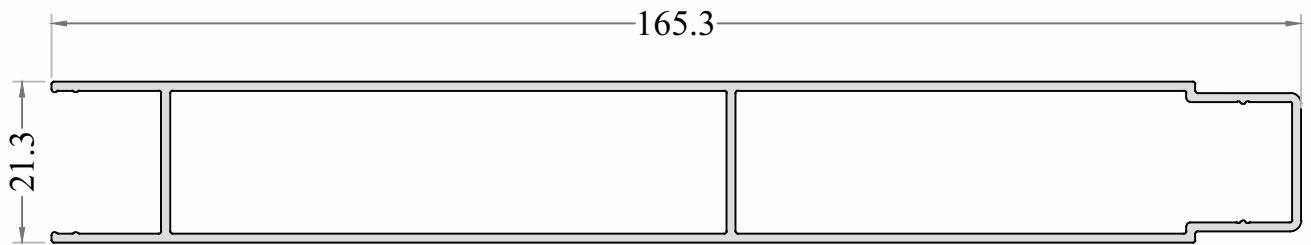

PLB-075	Lambri Ripado
Peso (Kg/m)	Perfis De Encaixe:
1,022	

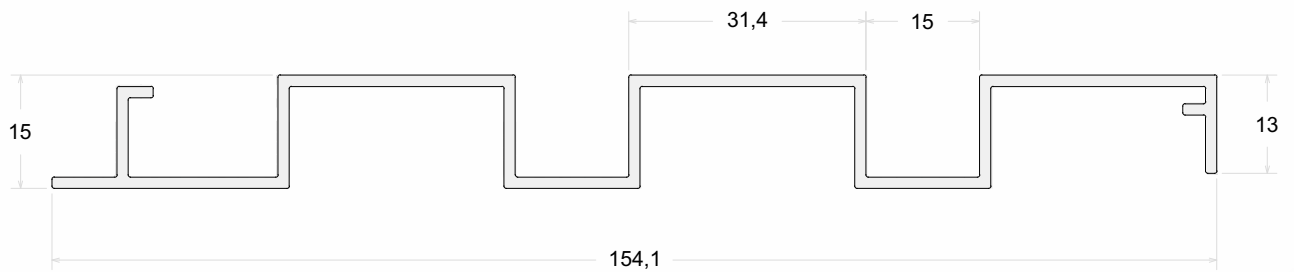

PLB-061 PLB-061L	Lambri Liso
Peso (Kg/m)	Perfis De Encaixe:
0,671 0,540	

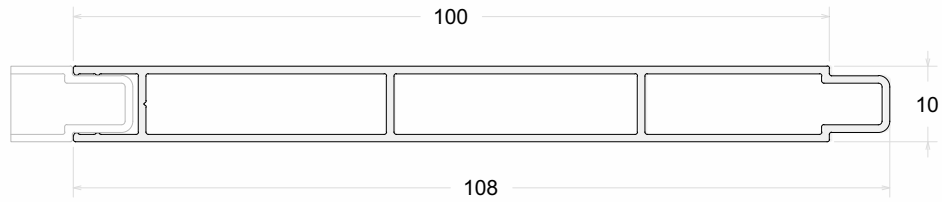

PLB-062	Lambri Friso
Peso (Kg/m)	Perfis De Encaixe:
0,225	

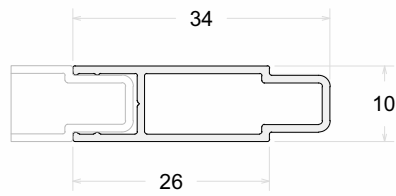

PLB-085	Lambri Ripado
Peso (Kg/m)	Perfis De Encaixe:
0,933	

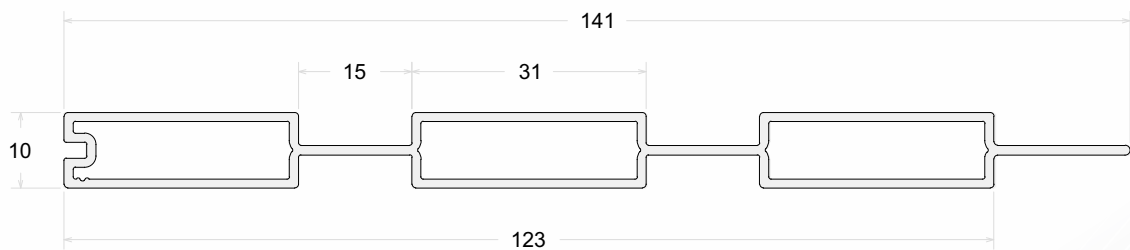

PLB-070	Lambri Negativo
Peso (Kg/m)	Perfis De Encaixe:
1,894	

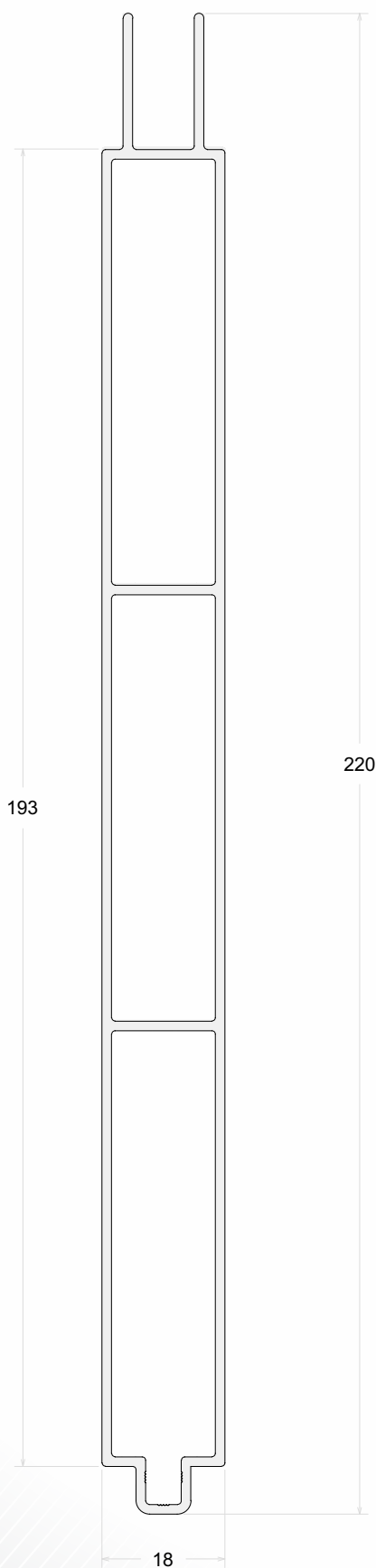

PLB-208	Lambri
Peso (Kg/m)	Perfis De Encaixe:
1,127	

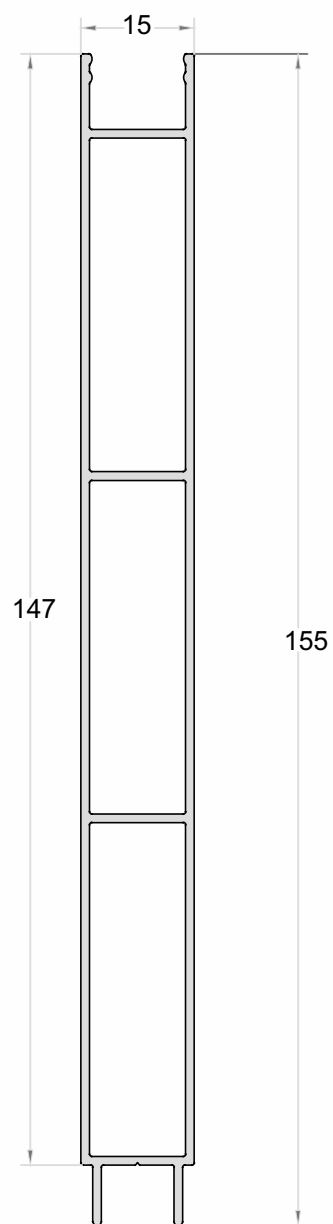

VZ-024	Veneziana
Peso (Kg/m)	Perfis De Encaixe:
0,217	

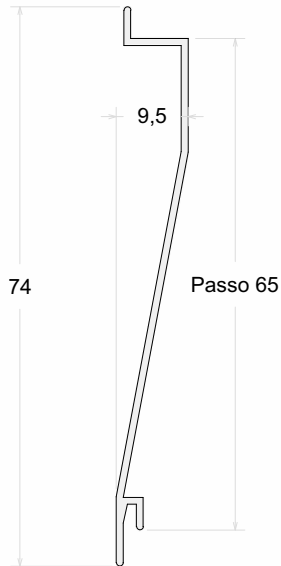

VZ-024VT	Veneziana Ventilada
Peso (Kg/m)	Perfis De Encaixe:
0,250	

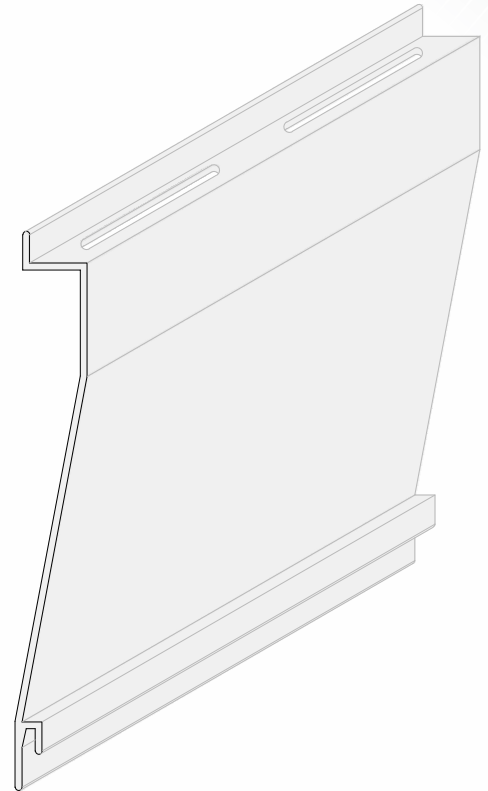

VZ-023	Veneziana
Peso (Kg/m)	Perfis De Encaixe:
0,317	

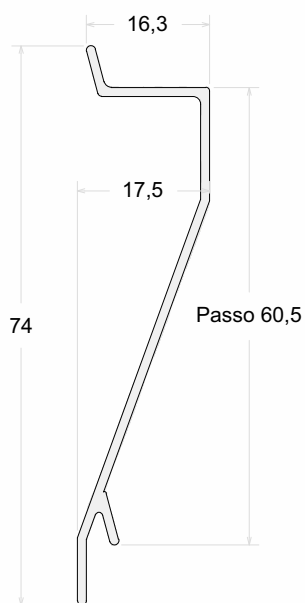

VZ-023VT	Veneziana Ventilada
Peso (Kg/m)	Perfis De Encaixe:
0,317	

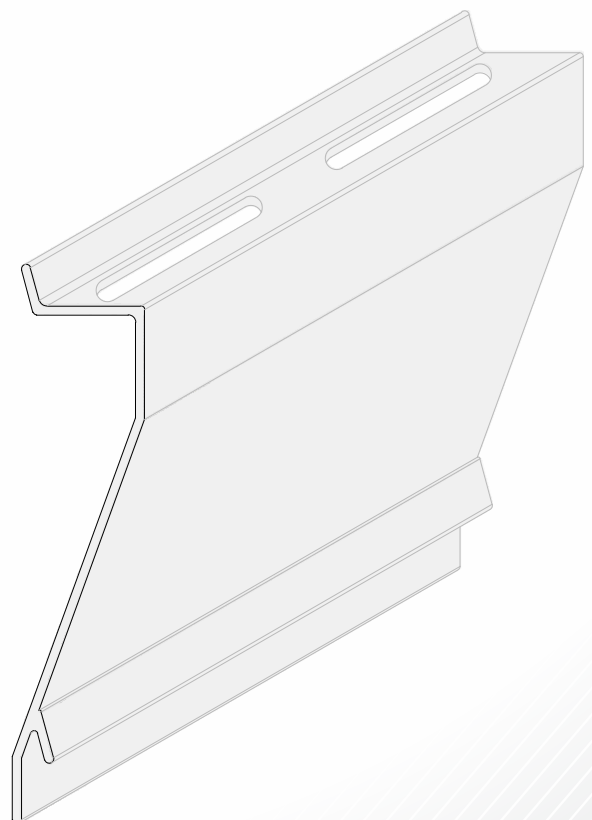

VZ-080	Veneziana
Peso (Kg/m)	Perfis De Encaixe:
0,222	

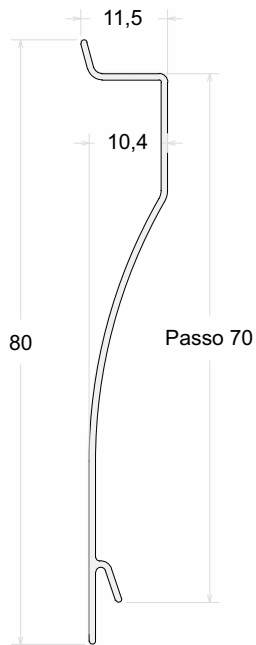

VZ-080VT	Veneziana Ventilada
Peso (Kg/m)	Perfis De Encaixe:
0,222	

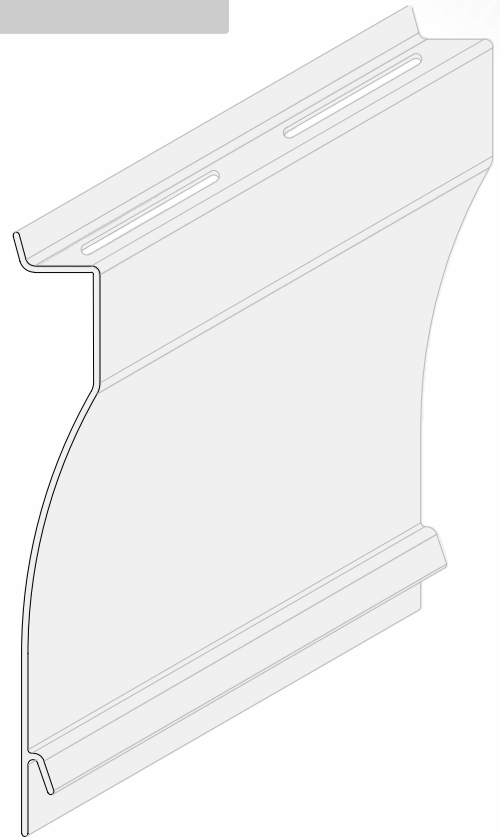

VZ-006	Veneziana
Peso (Kg/m)	Perfis De Encaixe:
0,269	

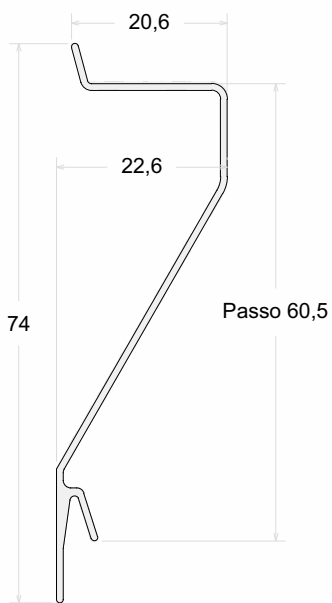

VZ-006VT	Veneziana Ventilada
Peso (Kg/m)	Perfis De Encaixe:
0,269	

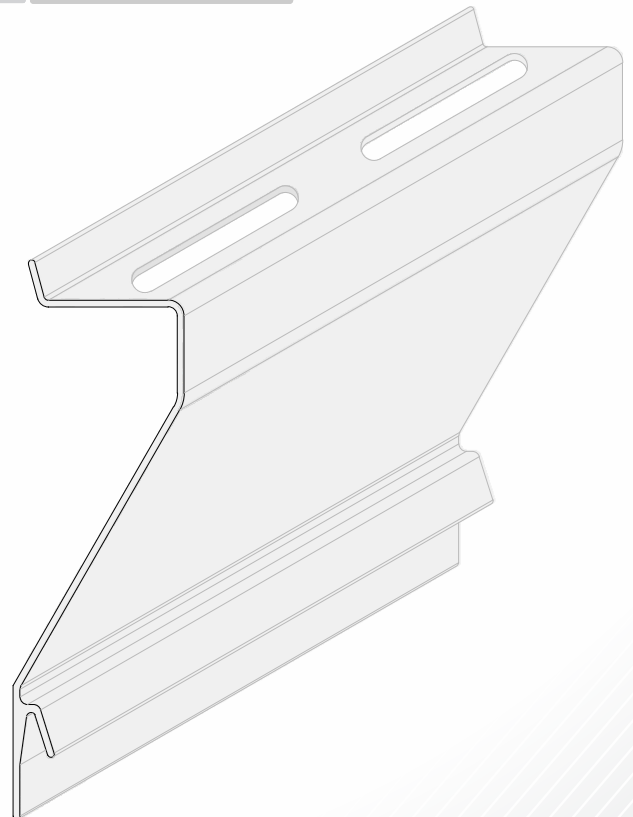

VZ-106	Veneziana
Peso (Kg/m)	Perfis De Encaixe:
0,405	

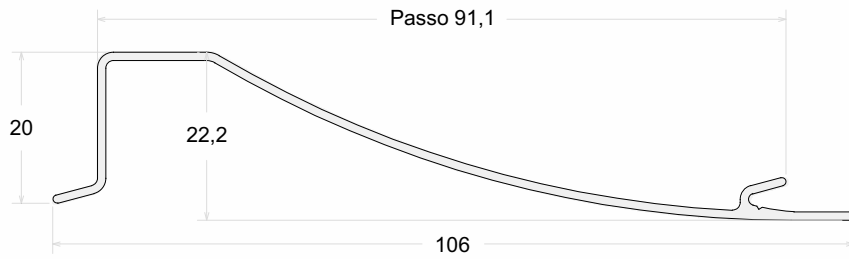

VZ-106VT	Veneziana Ventilada
Peso (Kg/m)	Perfis De Encaixe:
0,405	

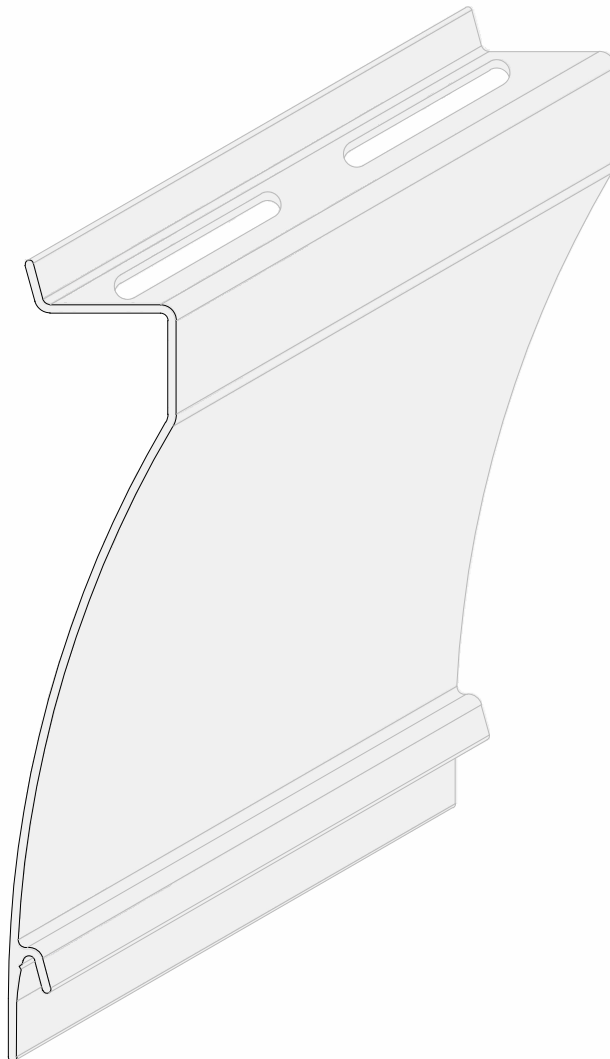

VZ-082	Veneziana
Peso (Kg/m)	Perfis De Encaixe:
0,280	

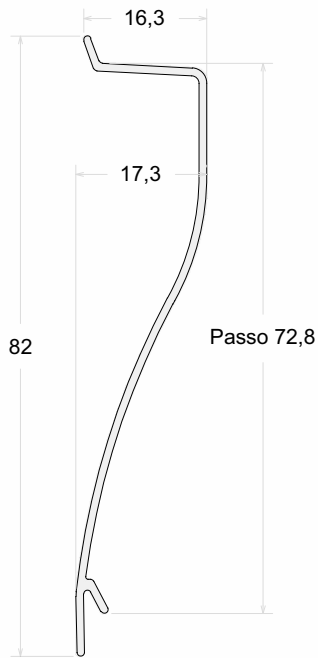

VZ-082VT	Veneziana Ventilada
Peso (Kg/m)	Perfis De Encaixe:
0,280	

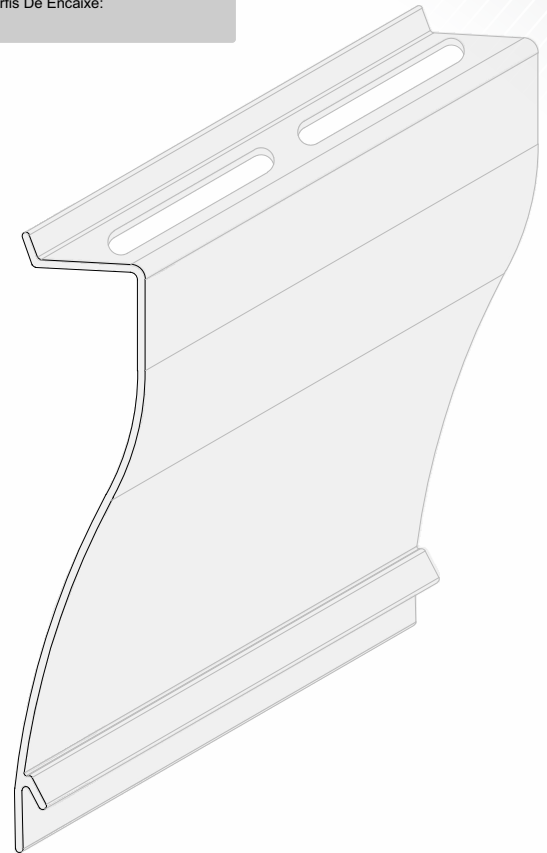

CX-642	Veneziana
Peso (Kg/m)	Perfis De Encaixe:
0,228	

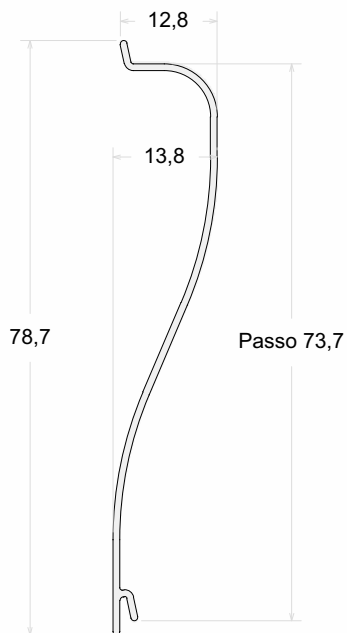

Z-163	Veneziana
Peso (Kg/m)	Perfis De Encaixe:
0,258	

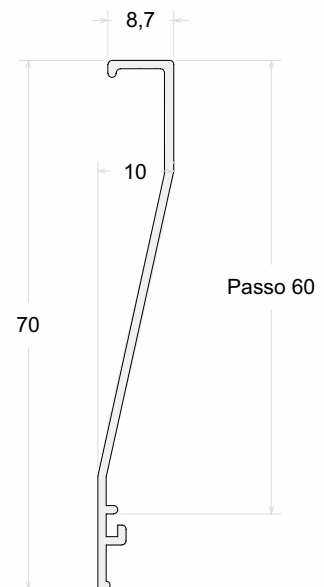

Y-145	Veneziana
Peso (Kg/m)	Perfis De Encaixe:
0,286	

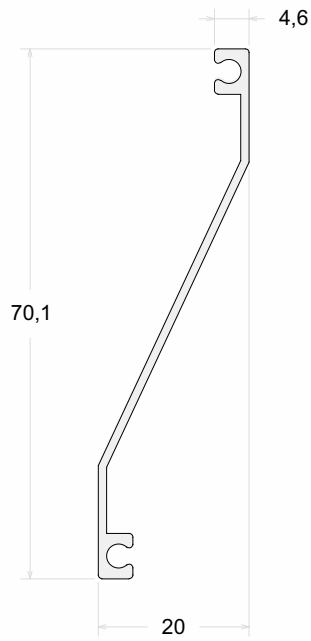

Z-284	Veneziana
Peso (Kg/m)	Perfis De Encaixe:
0,269	

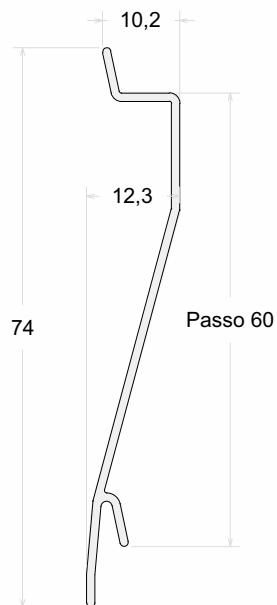

Perfis
25-542
25-543
25-544

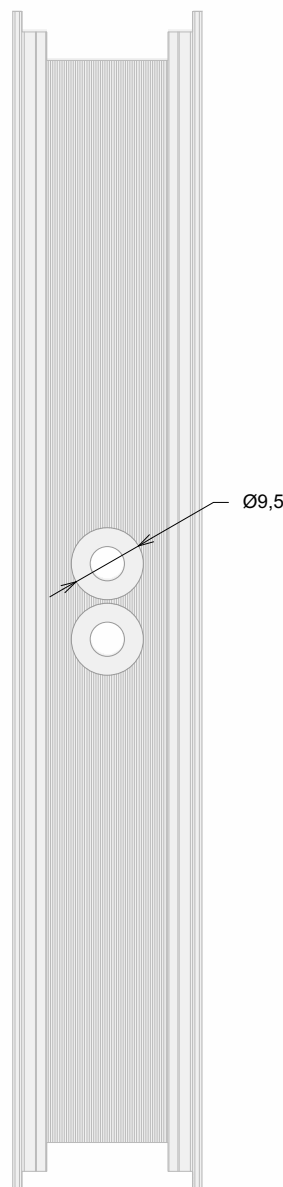
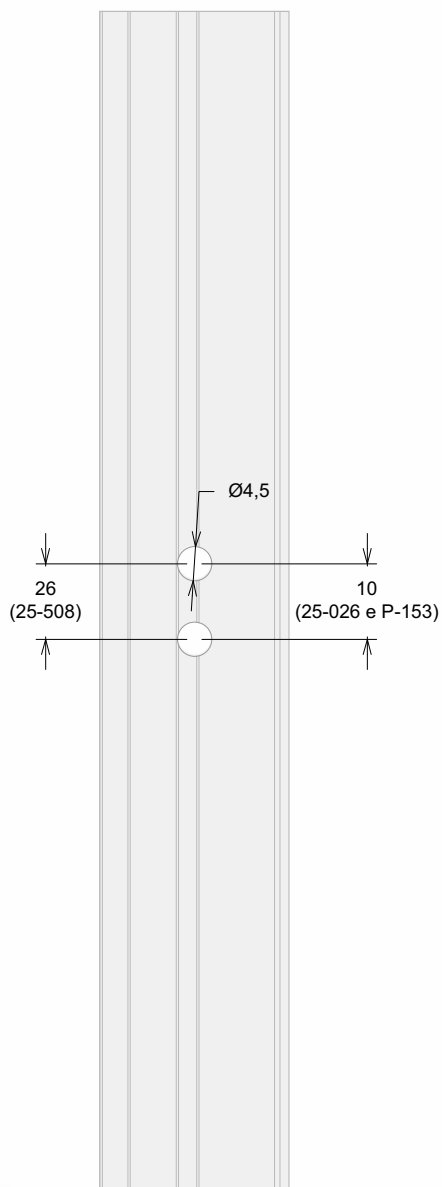
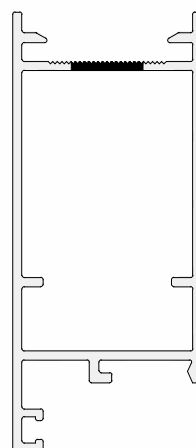
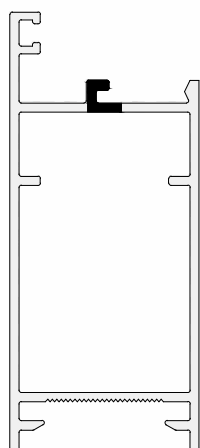

Perfis
P-153
25-026
25-508

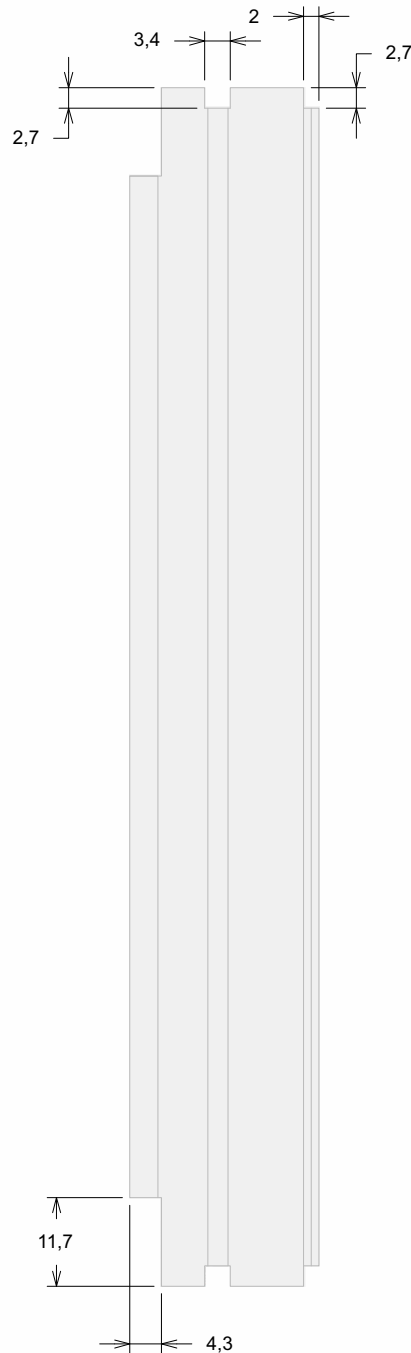
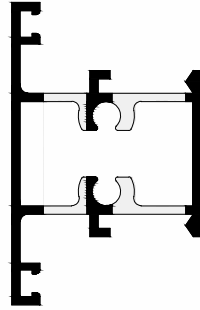

Detalhe De Encaixe



Perfis
PSU-111

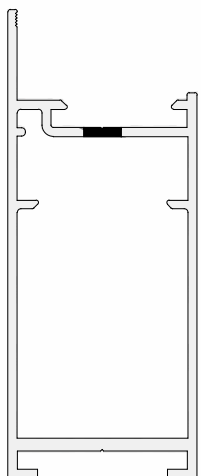

Porta Fechamento 90°

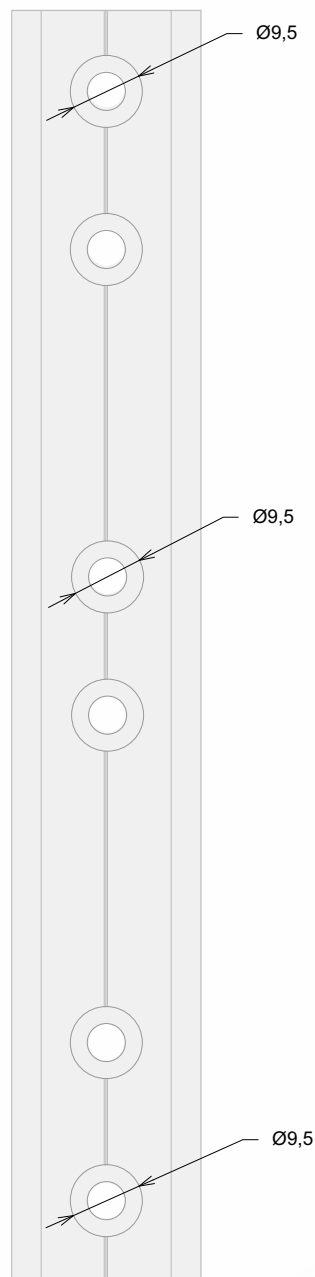
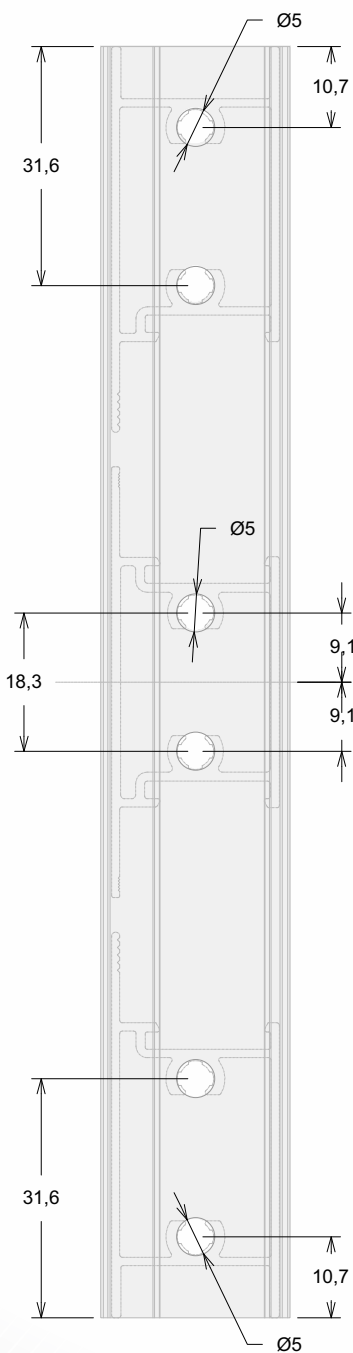
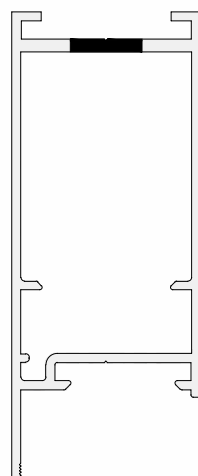

de $\text{Ø}9,5$ ou $\text{Ø}10\text{mm}$ para encaixe das tampas de
amento NYL-042.

Perfis
PEI-012

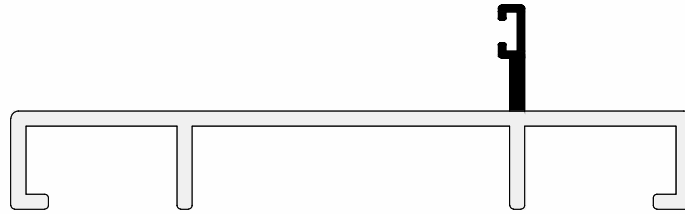

Perfis
PPO-002
PPO-007

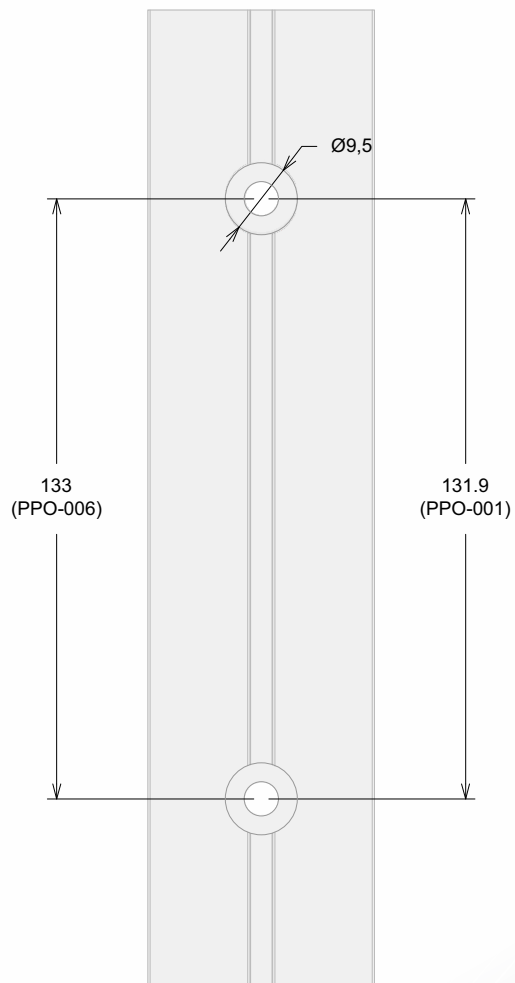
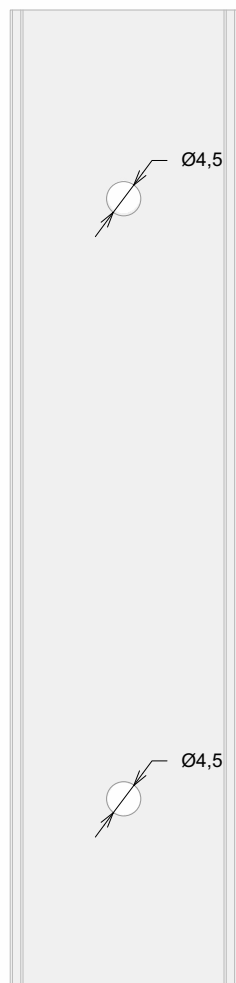
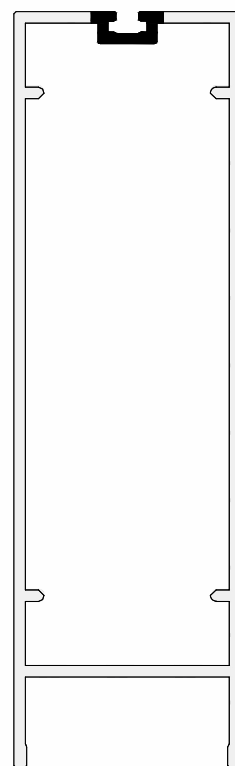
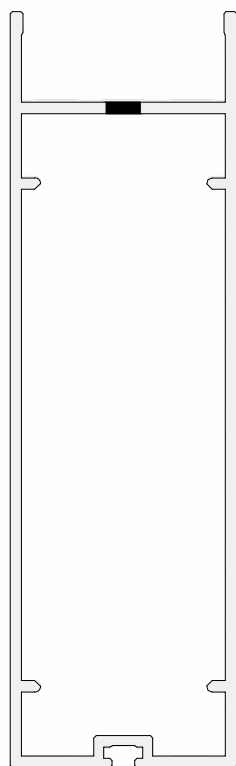

Perfis
PPO-003
PPO-005
P-264

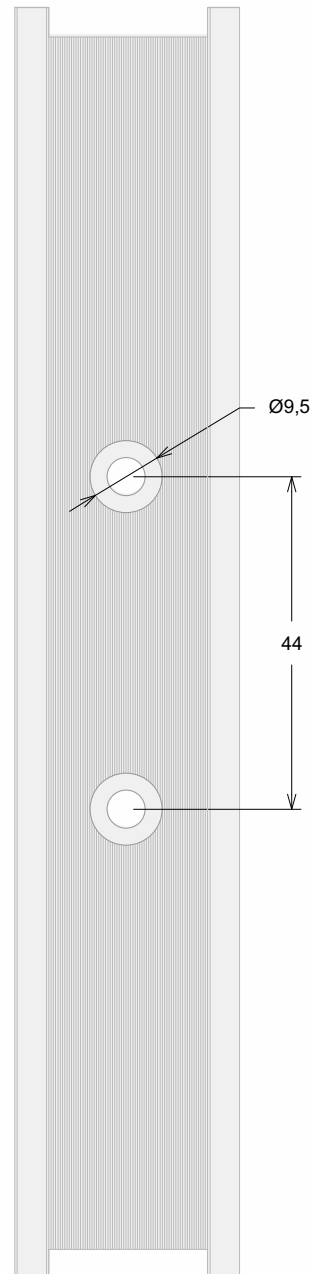
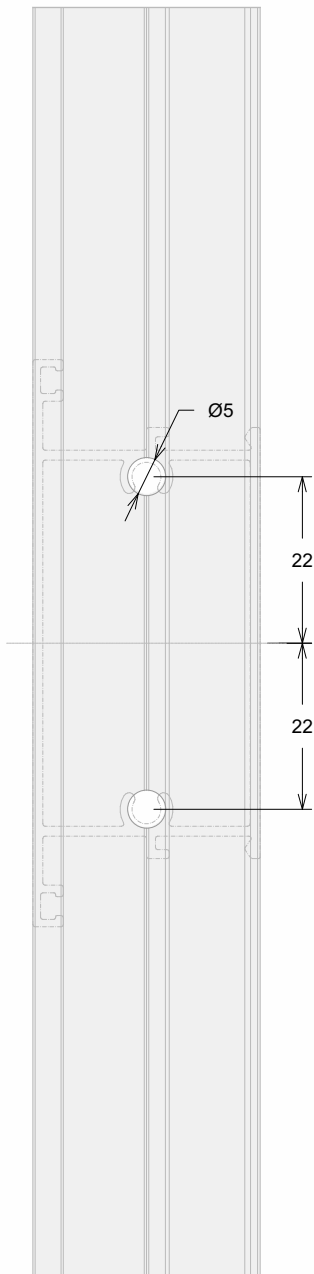
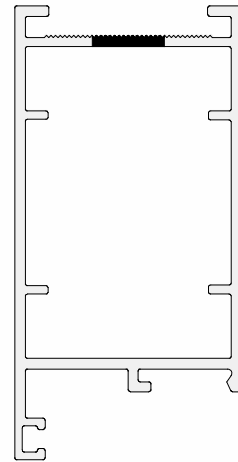
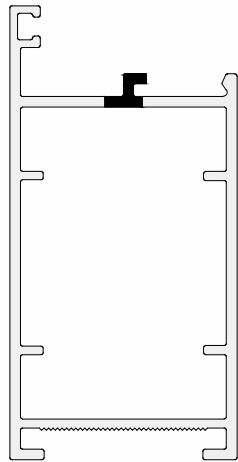

Perfis
PPO-004

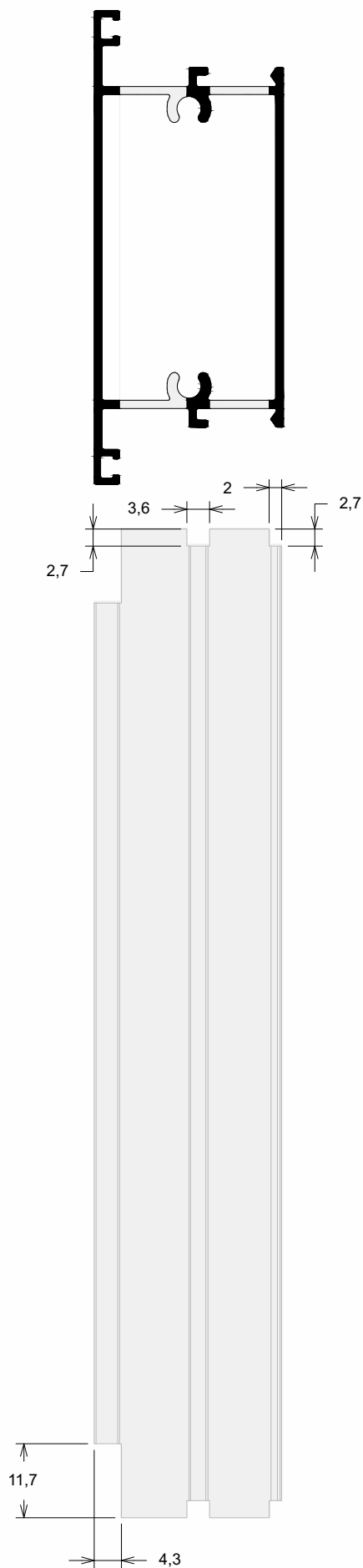

Detalhe De Encaixe



Perfis
PLG-239

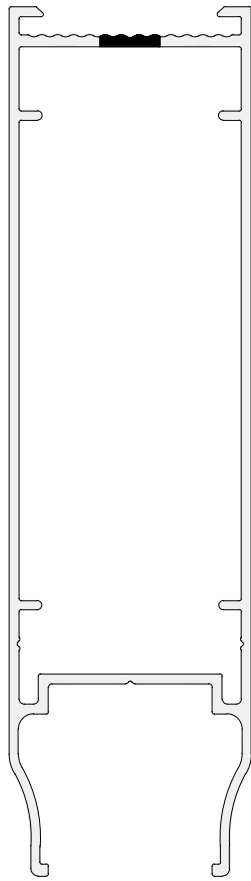

Detalhe Conexão 45° PLG-239

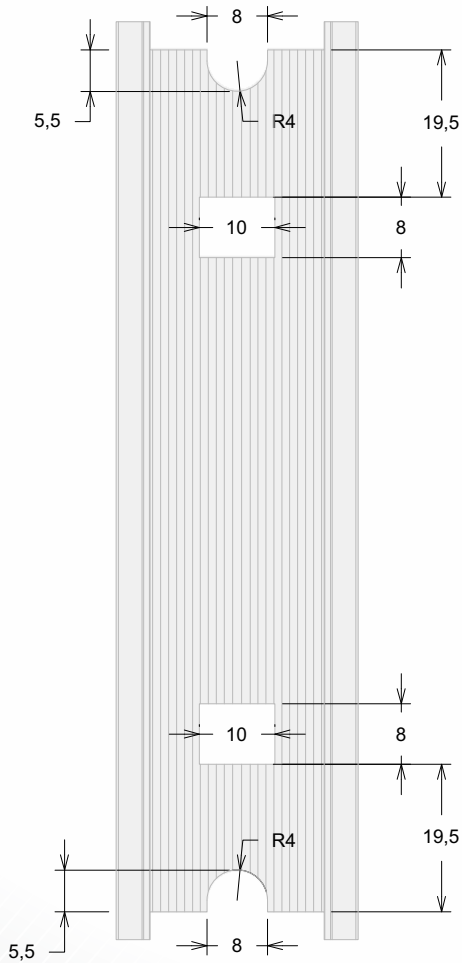
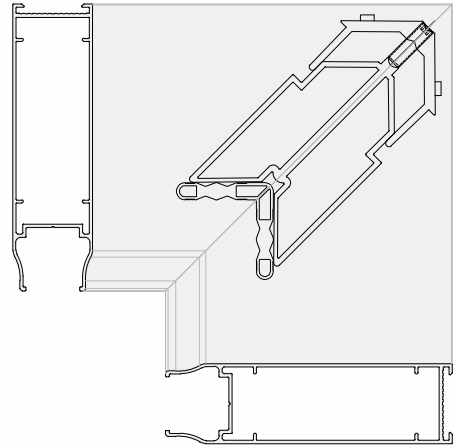

Detalhe Do Quadro

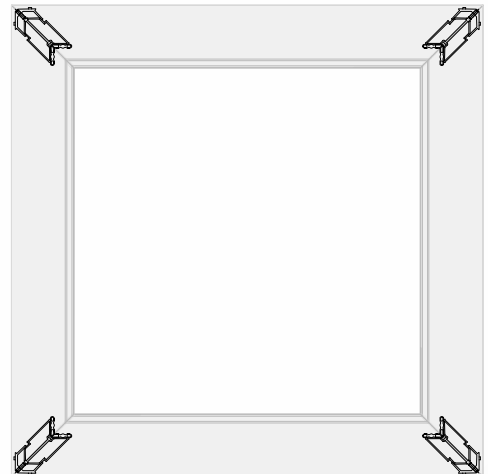

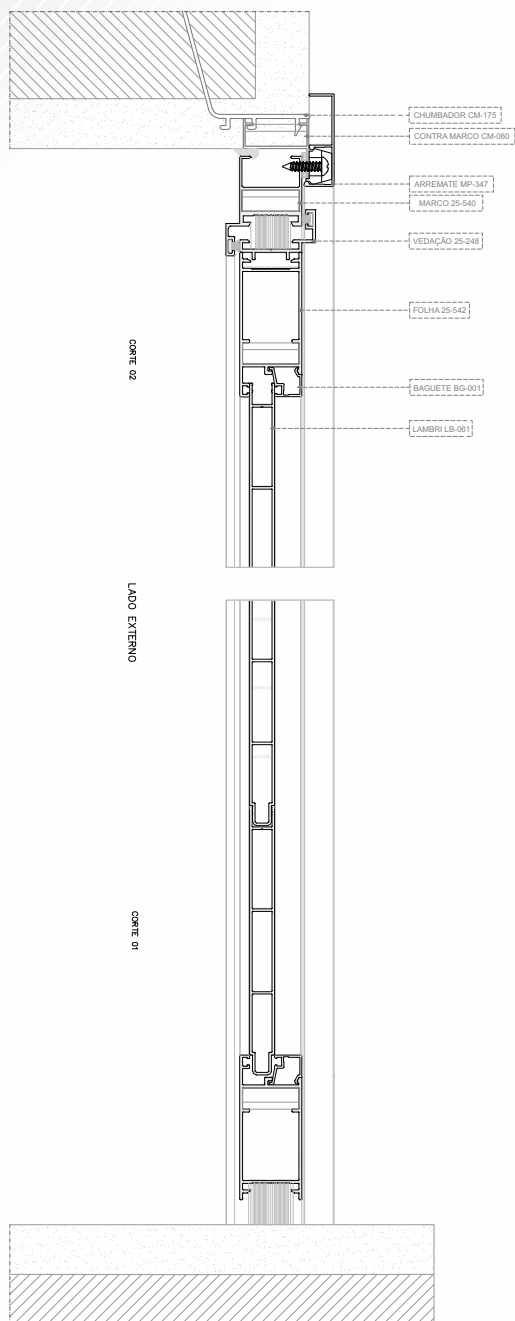

PORTA DE GIRO 1 FOLHA COM LAMBRI

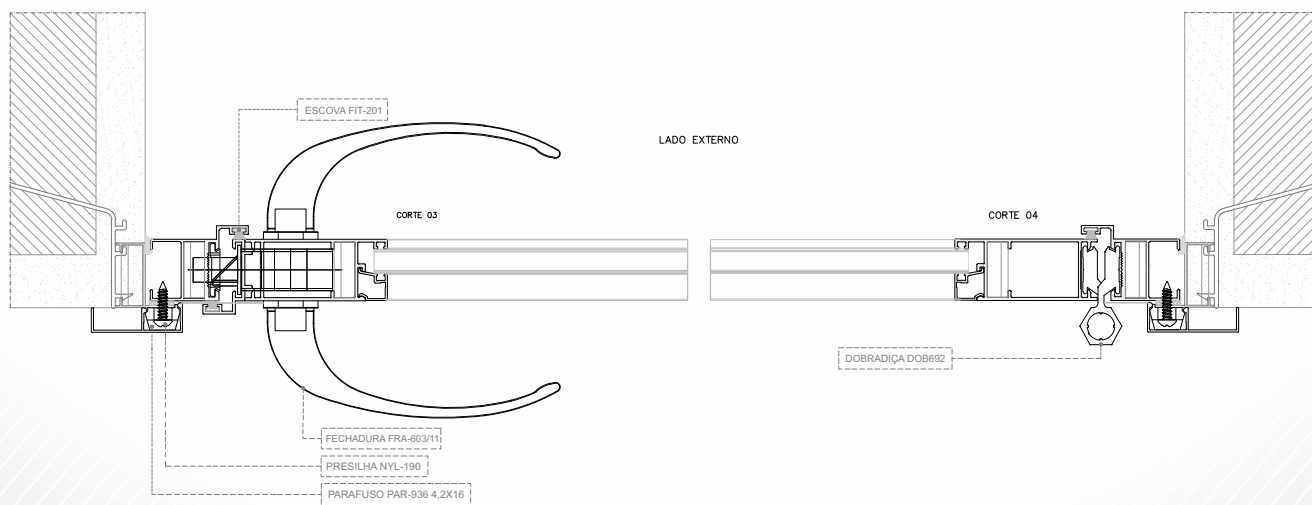
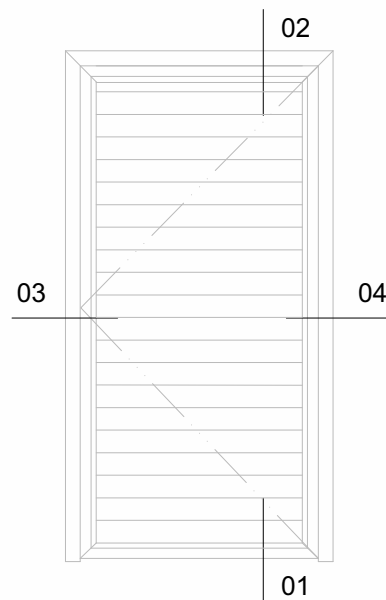

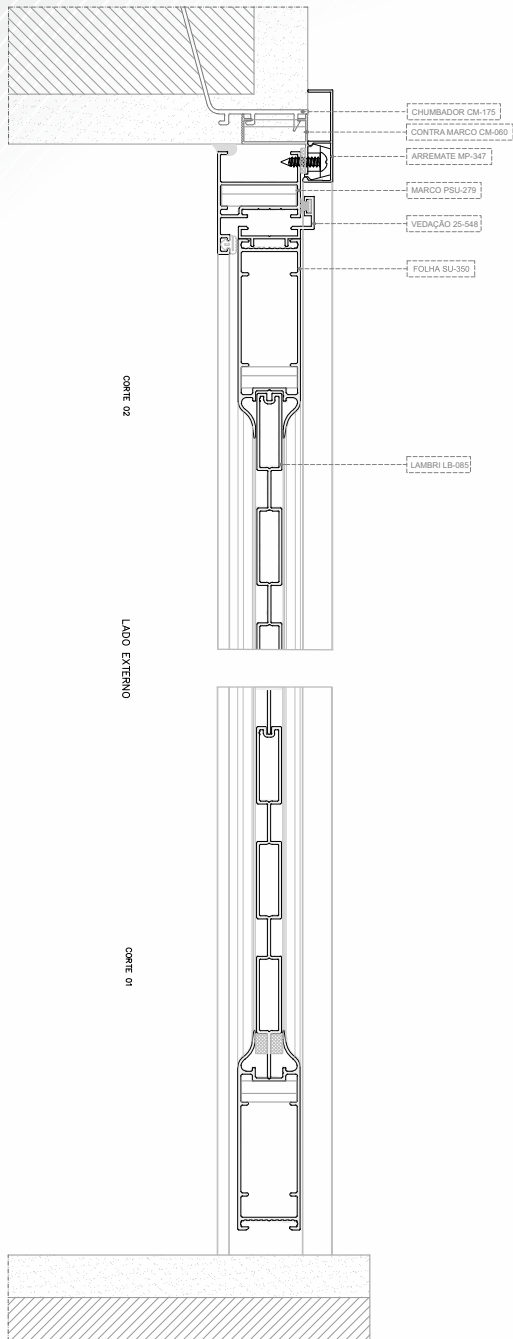

PORTA DE GIRO 1 FOLHA COM LAMBRI

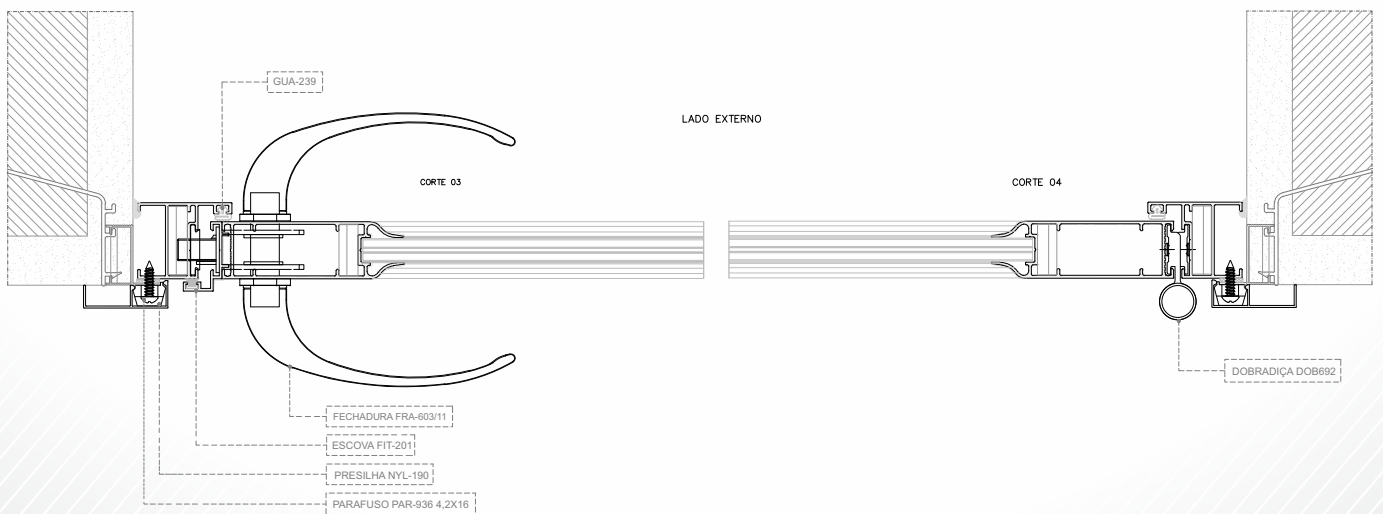
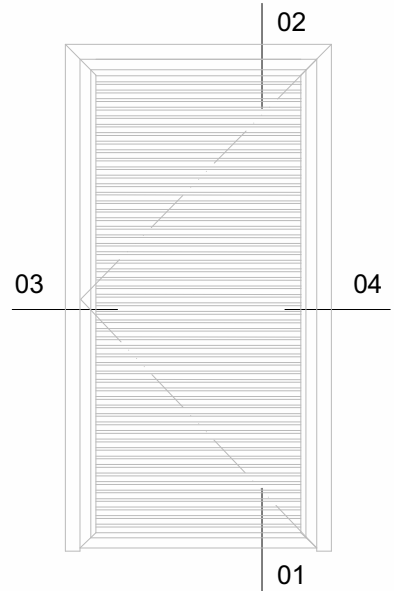

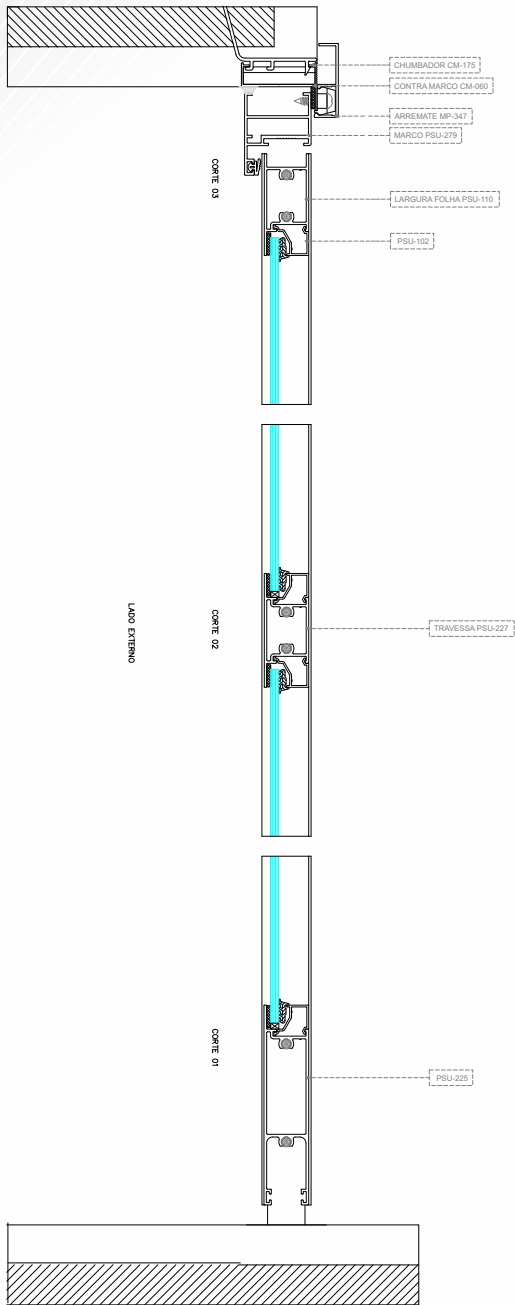

PORTA DE GIRO 1 FOLHA COM VIDRO

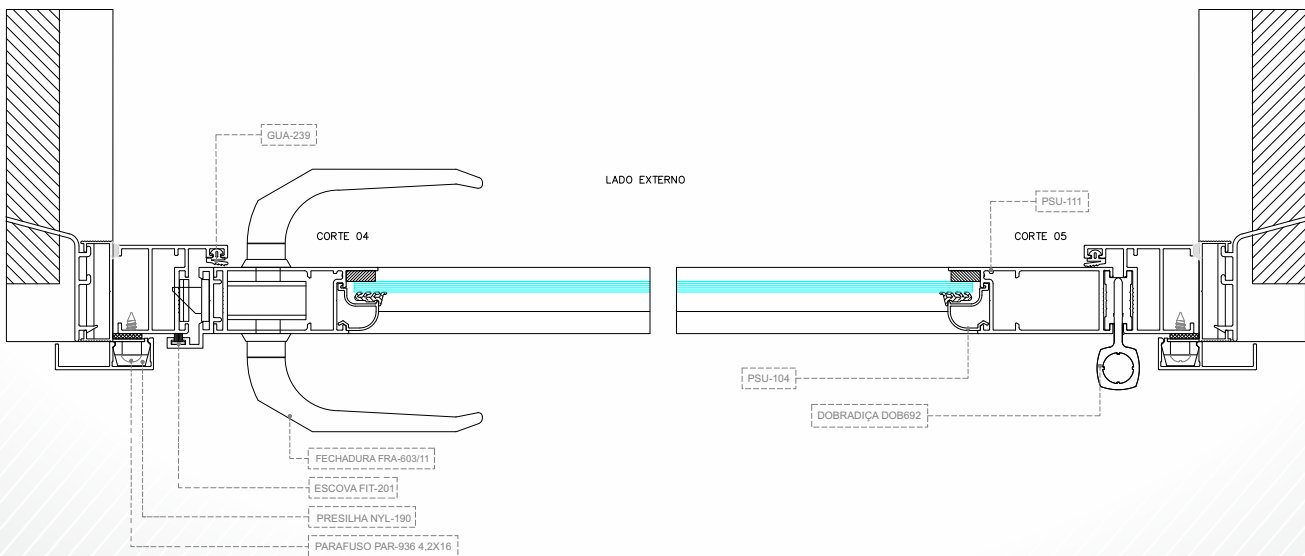
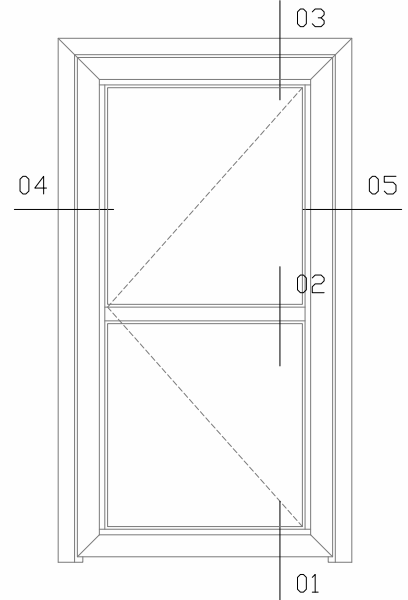

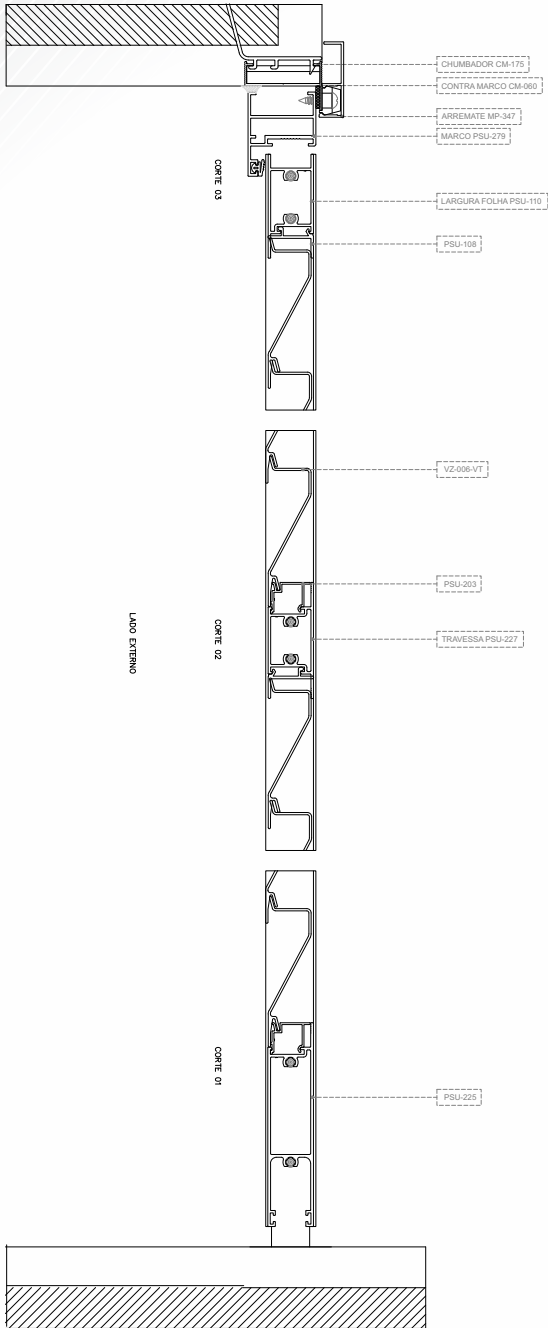

PORTA DE GIRO 1 FOLHA COM VENEZIANA

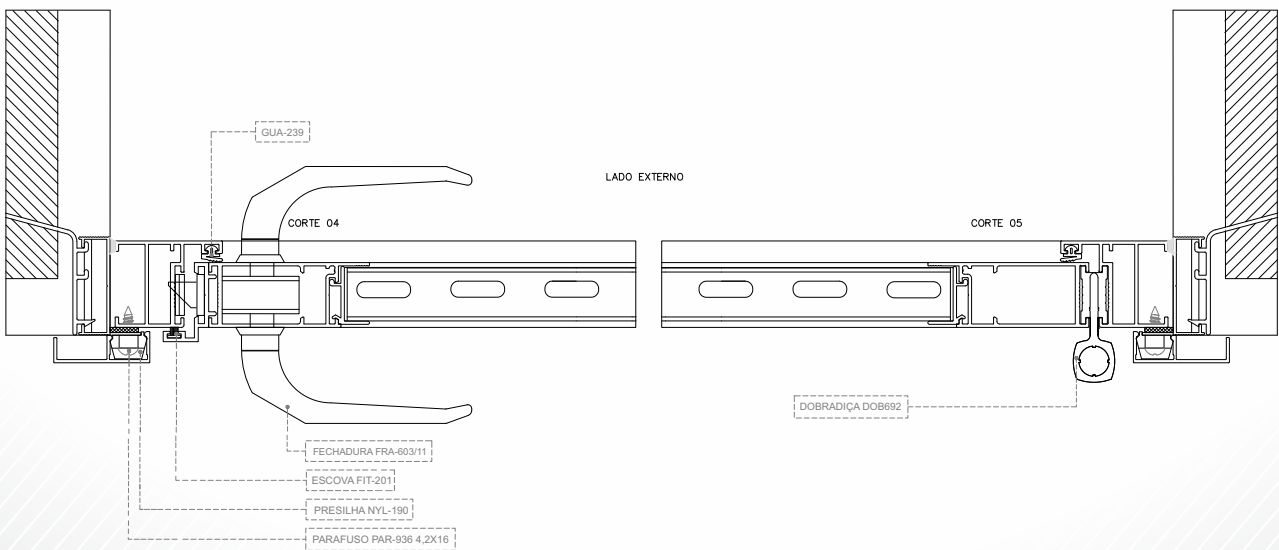
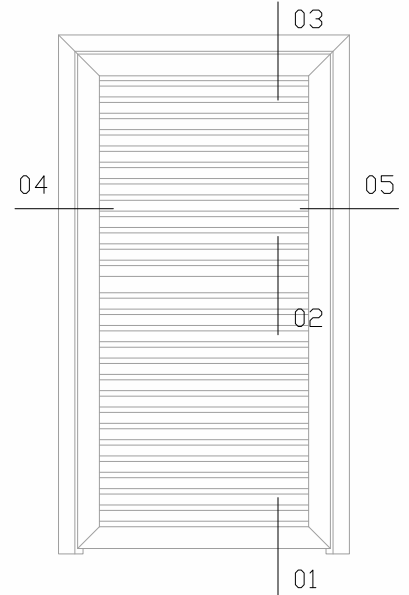

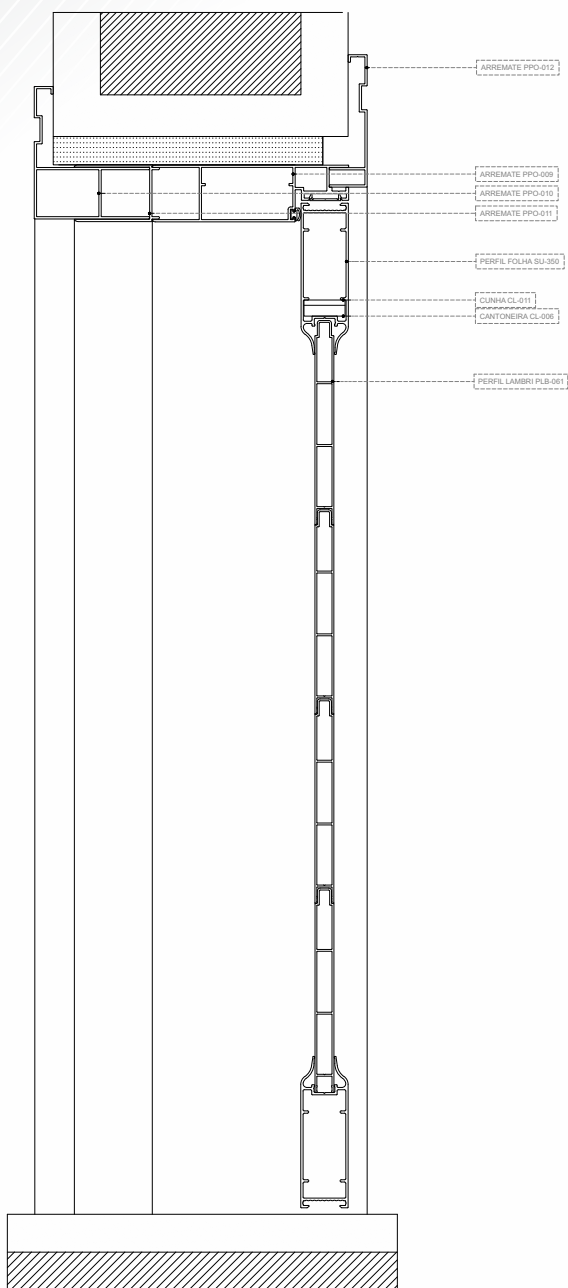

PORTA DE GIRO 1 FOLHA COM LAMBRI

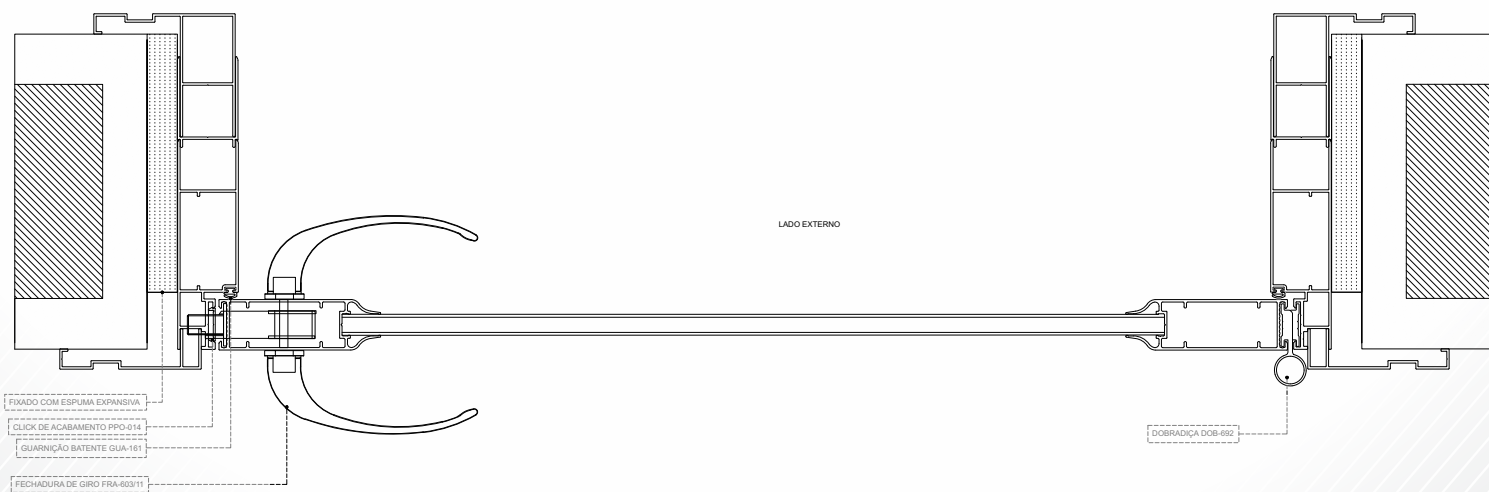
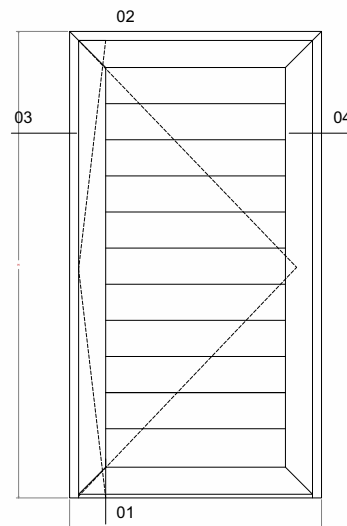

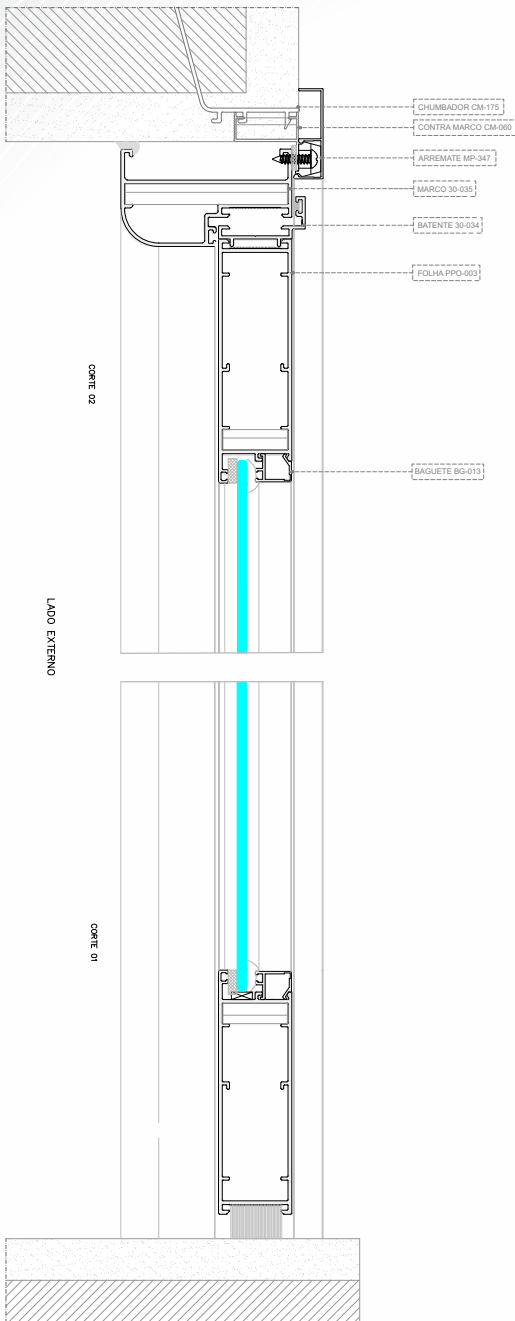

PORTA DE GIRO 1 FOLHA COM VIDRO

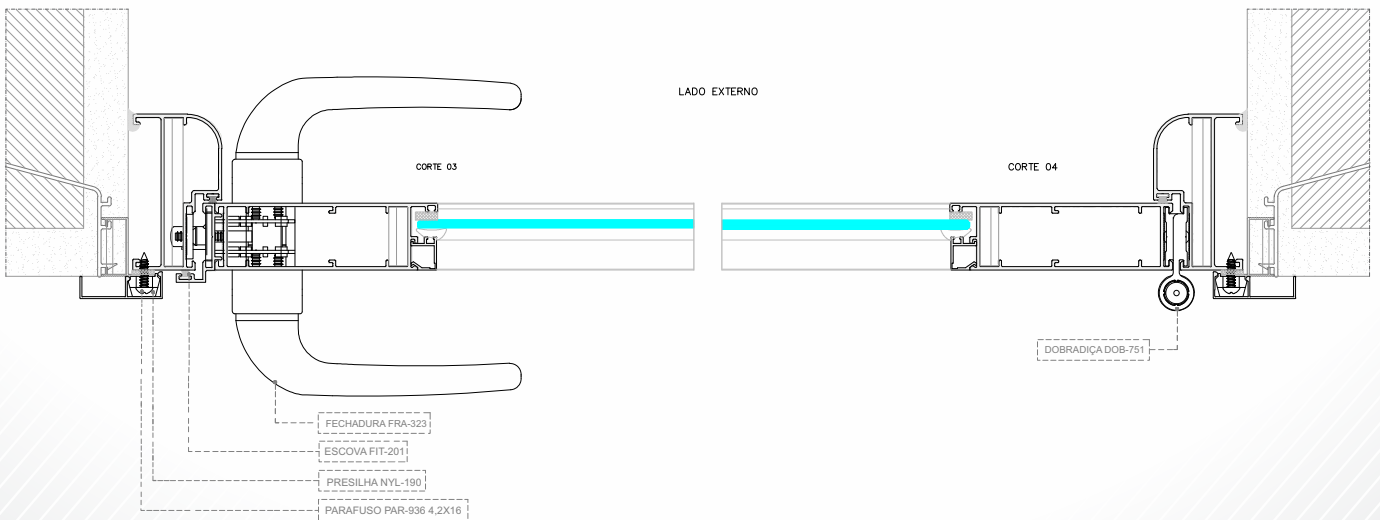
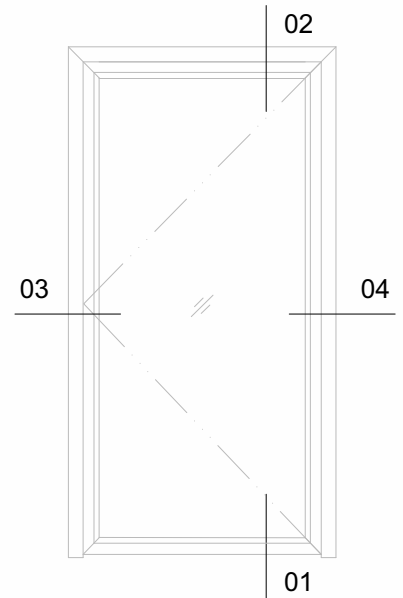

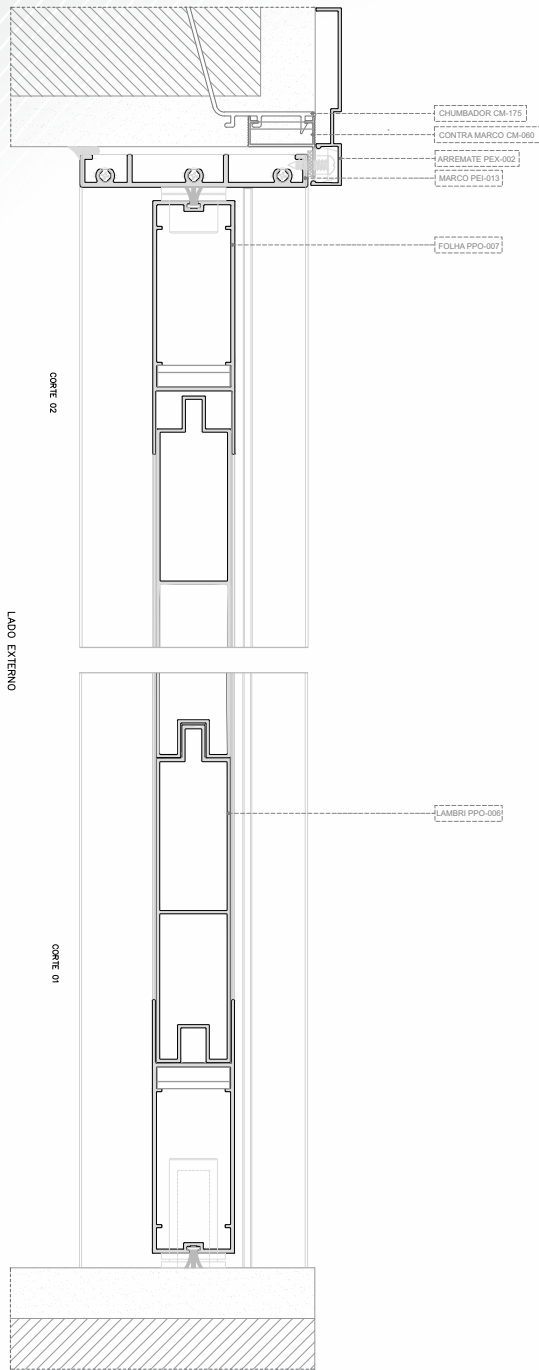

PORTA DE GIRO 1 FOLHA COM LAMBRI DUPLO

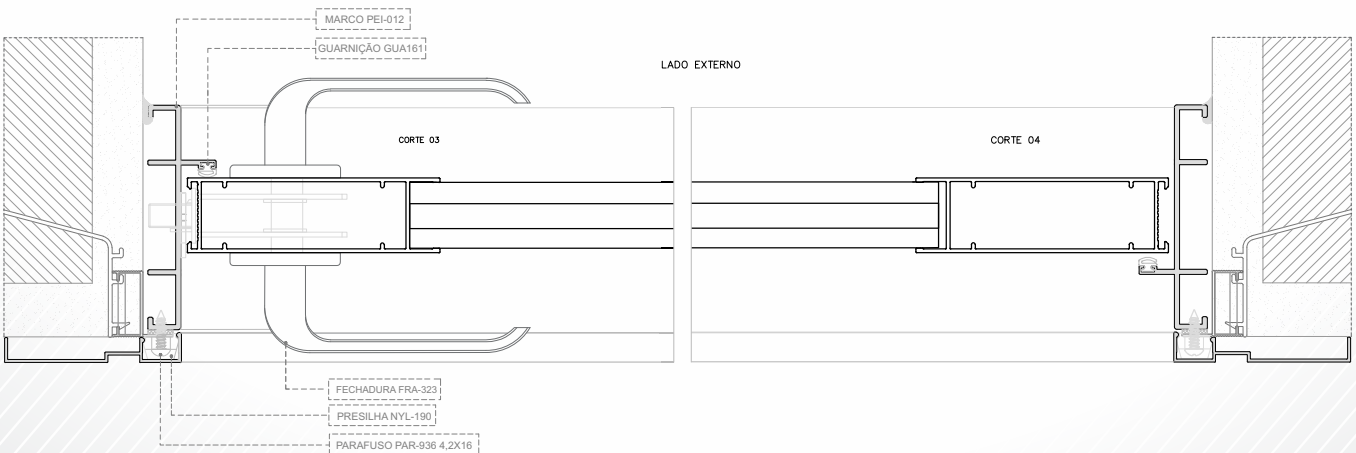
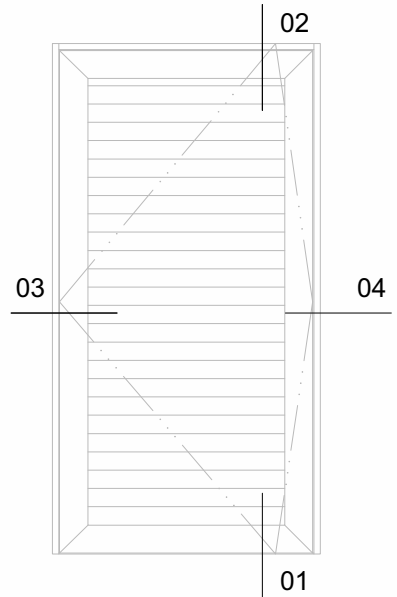

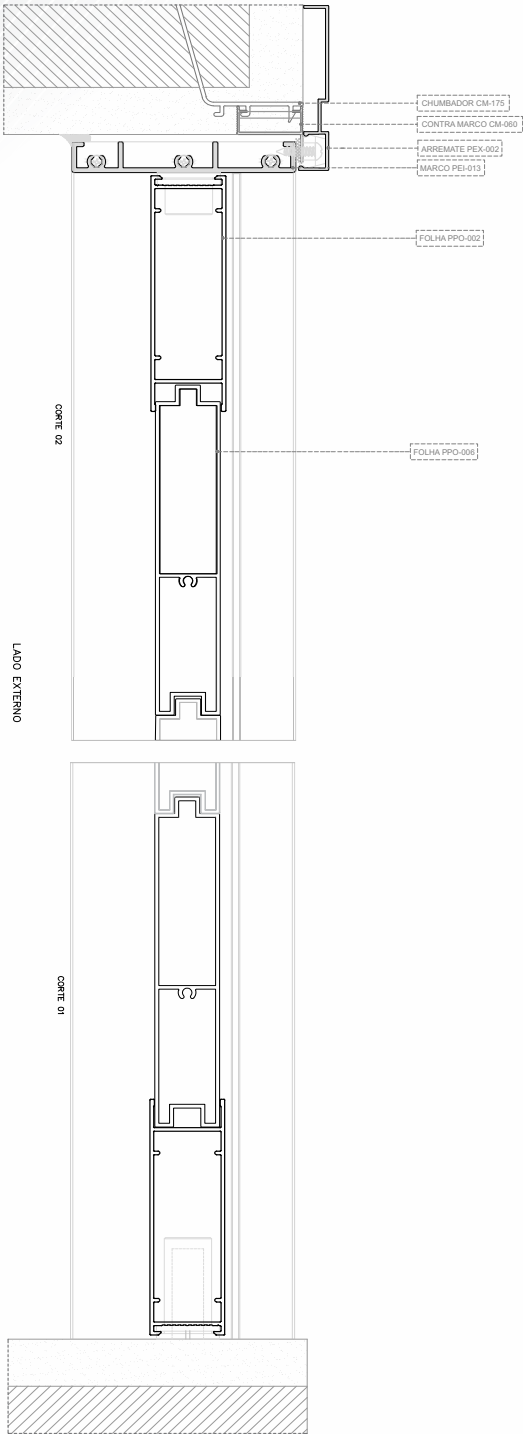

PORTA DE GIRO 1 FOLHA COM LAMBRI DUPLO

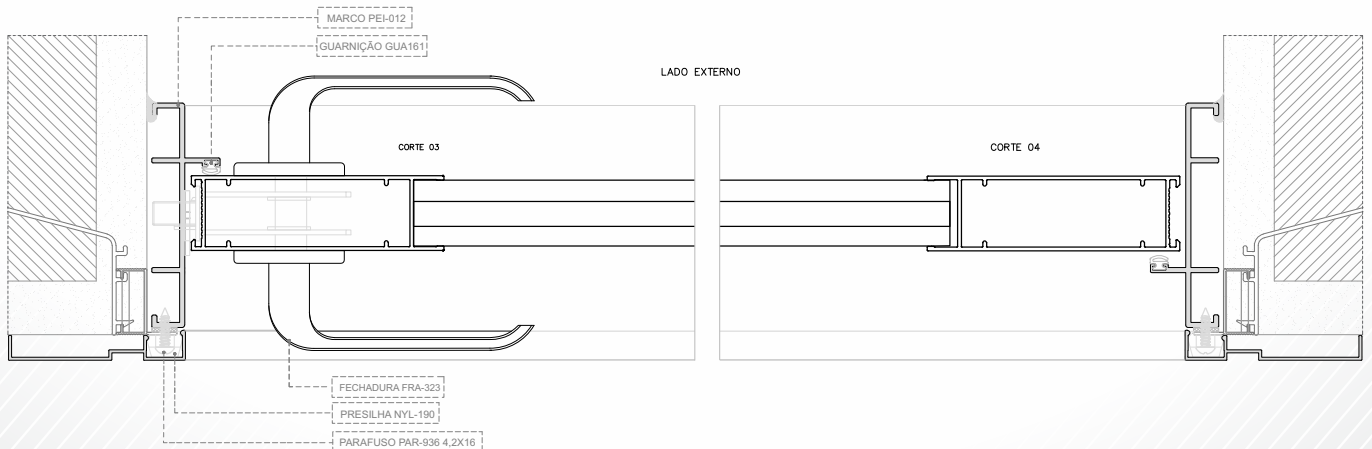
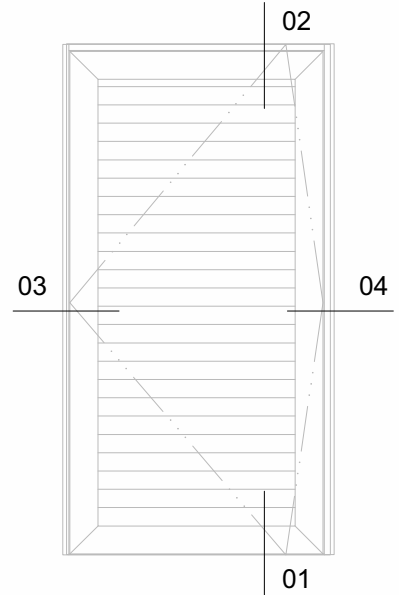

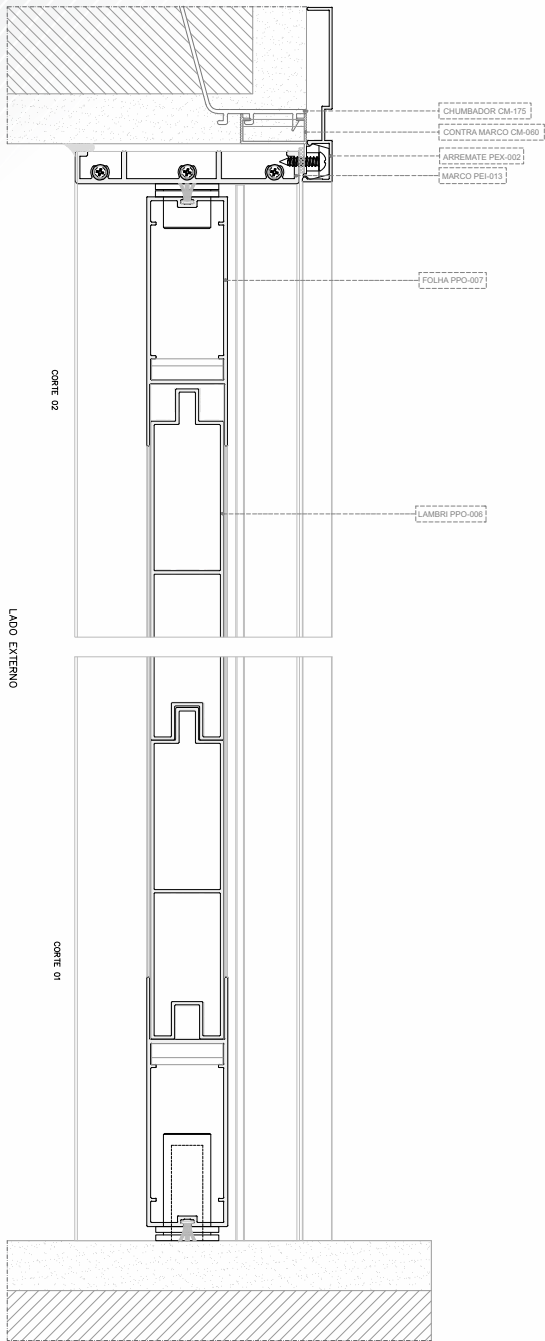

PORTA PIVOTANTE 1 FOLHA COM LAMBRI DUPLO

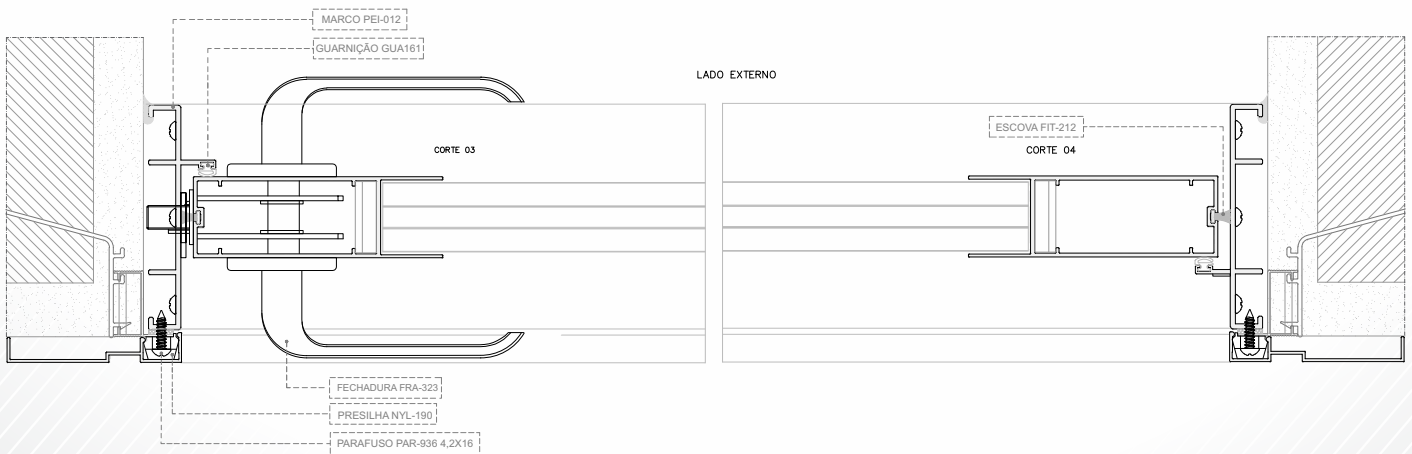
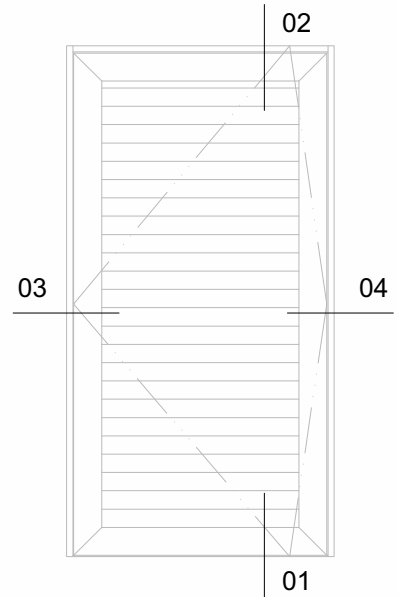

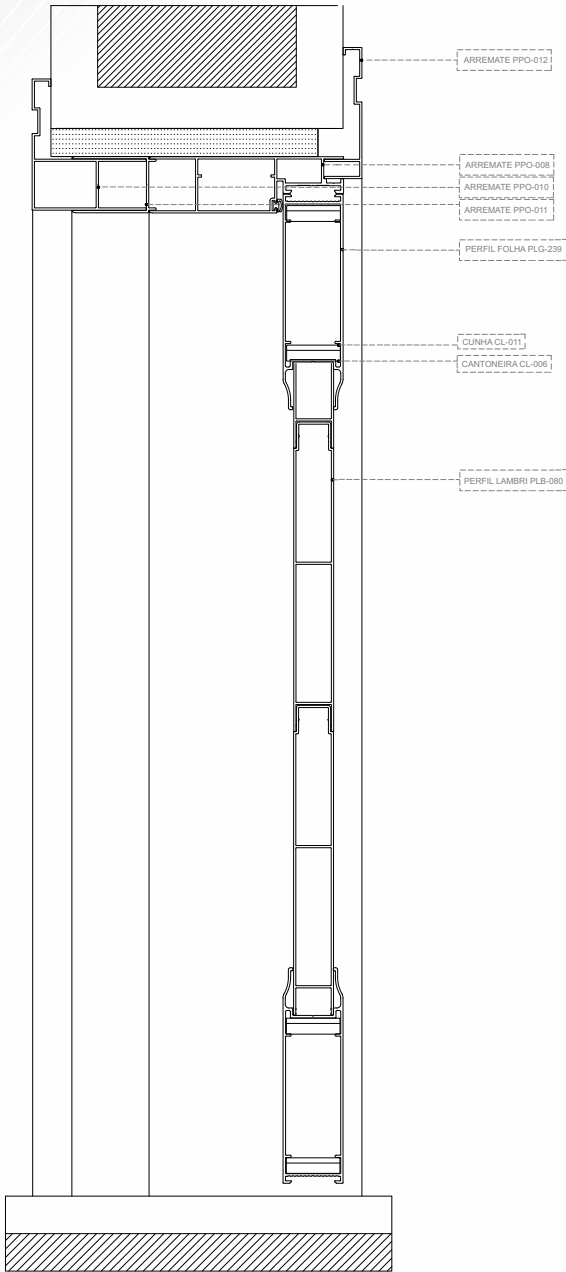

PORTA DE GIRO 1 FOLHA COM LAMBRI

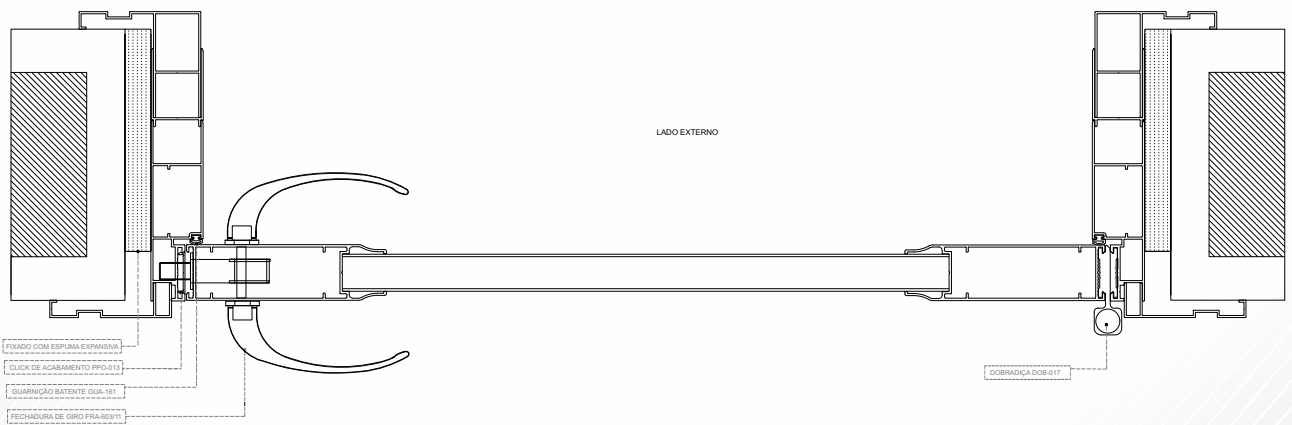
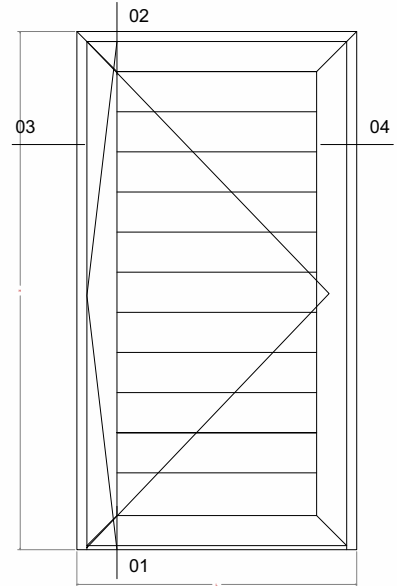

ONIBENS 0207

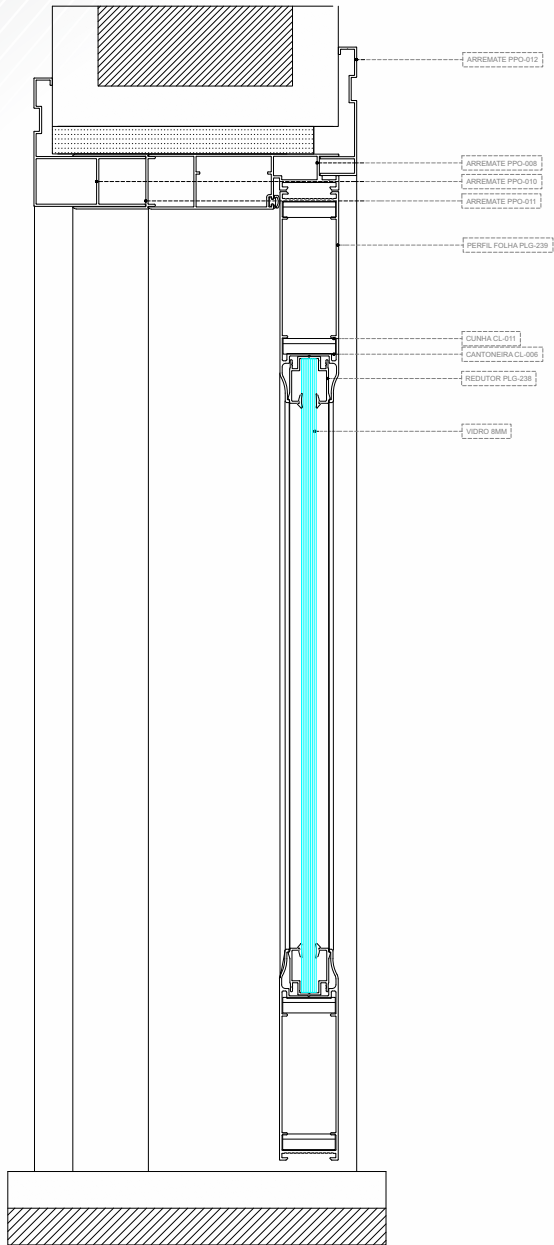

PORTA DE GIRO COM REDOR E VIDRO

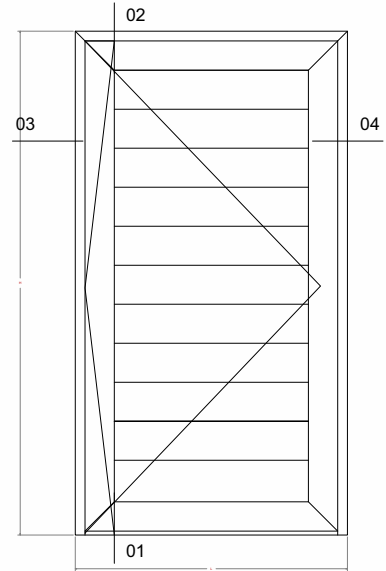

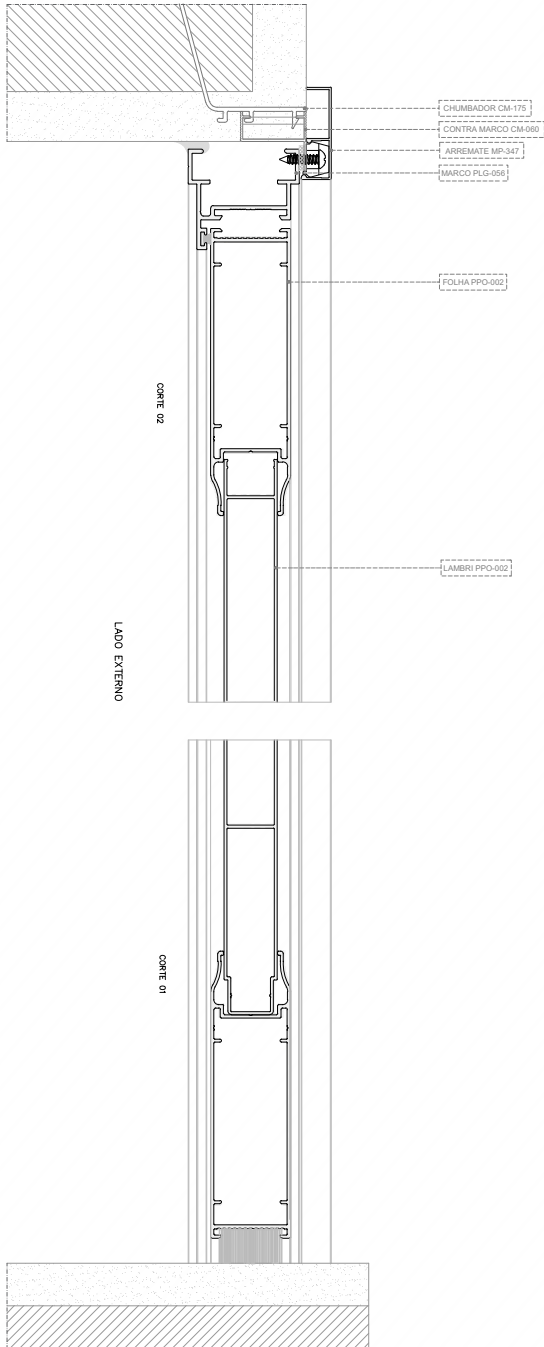

PORTA DE GIRO 1 FOLHA COM LAMBRI DUPLO

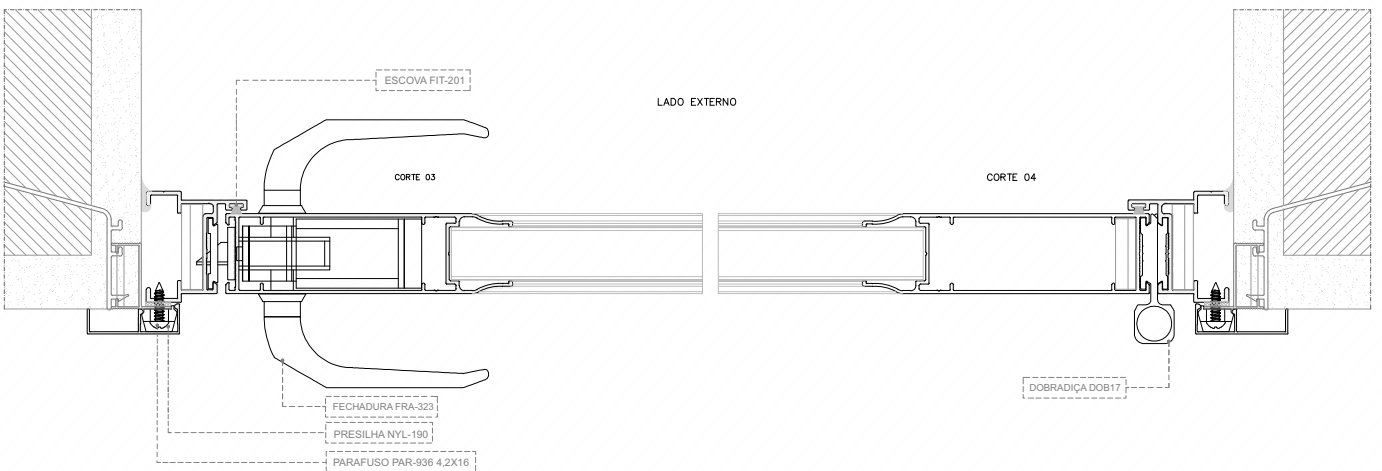
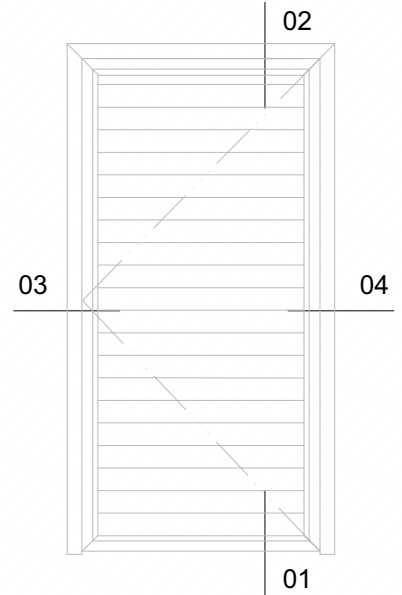

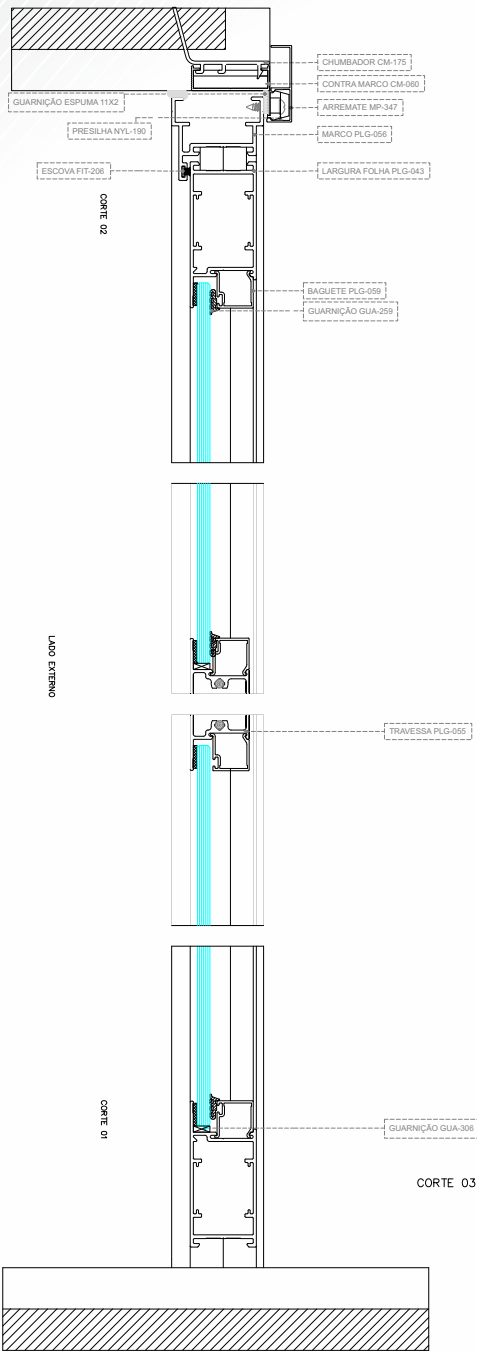

PORTA DE GIRO COM UMA FOLHA COM VIDRO

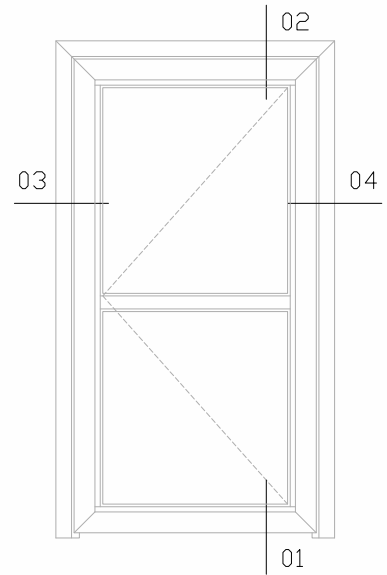

LADO EXTERNO

CORTE 04

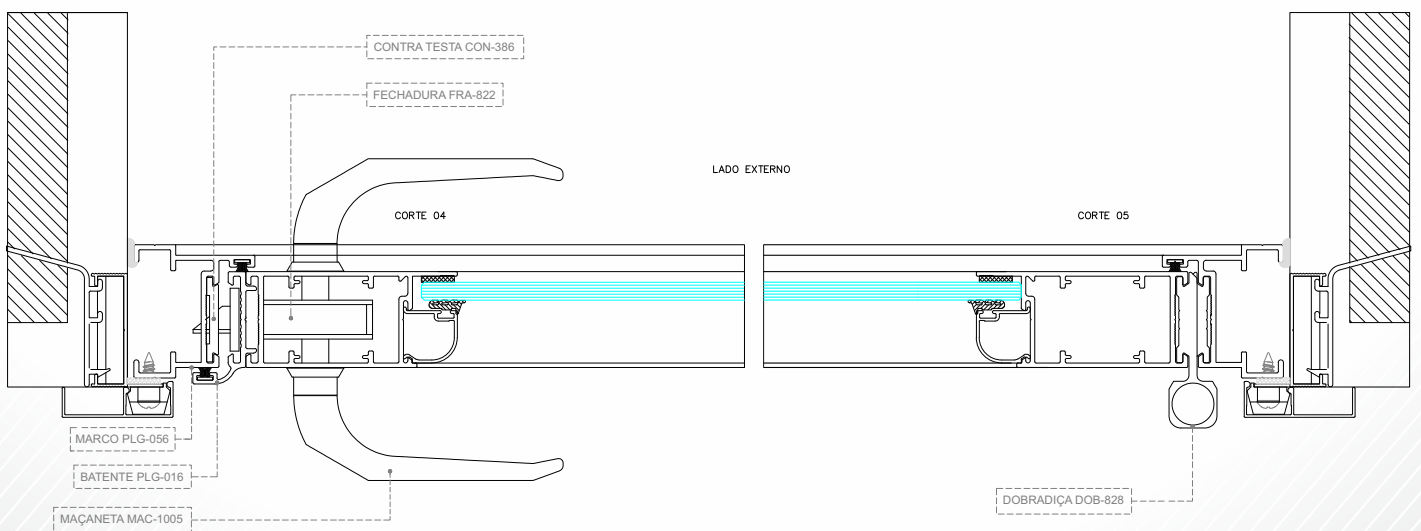

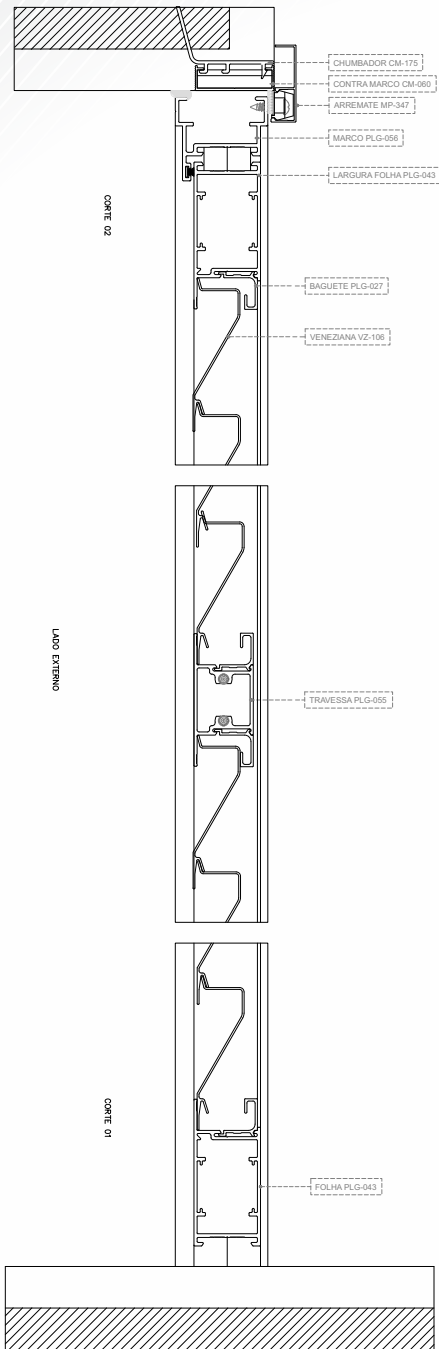

PORTA DE GIRO COM UMA FOLHA COM VENEZIANA TOTAL

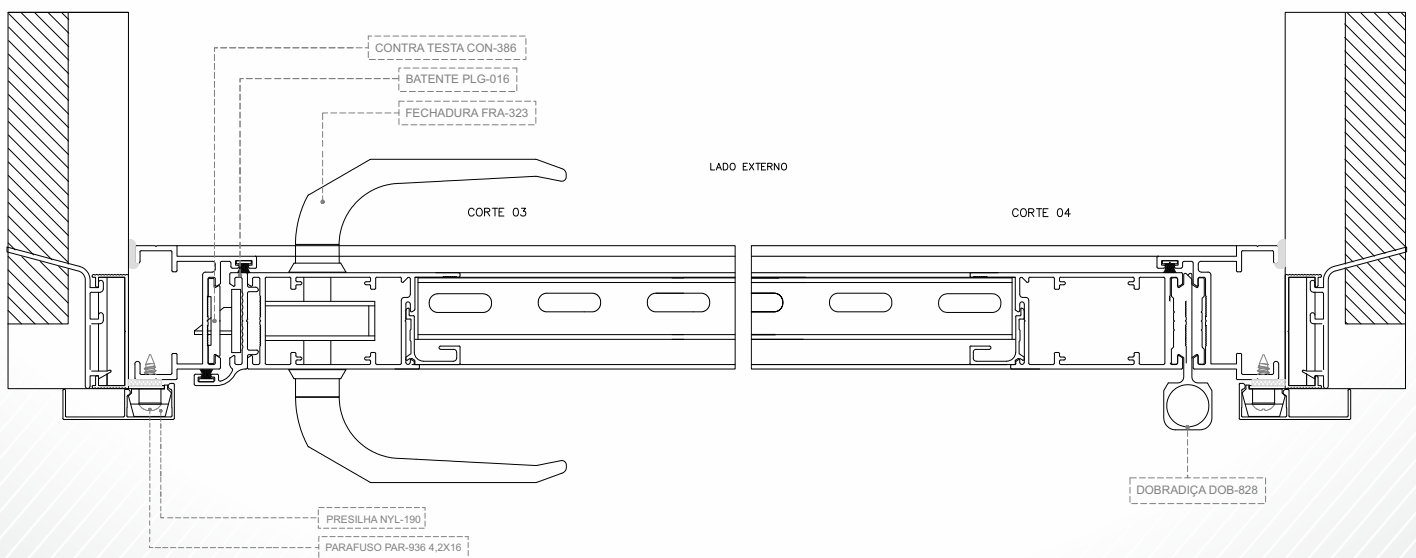
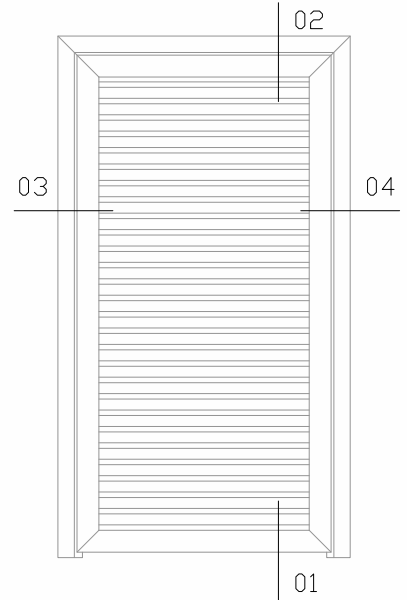

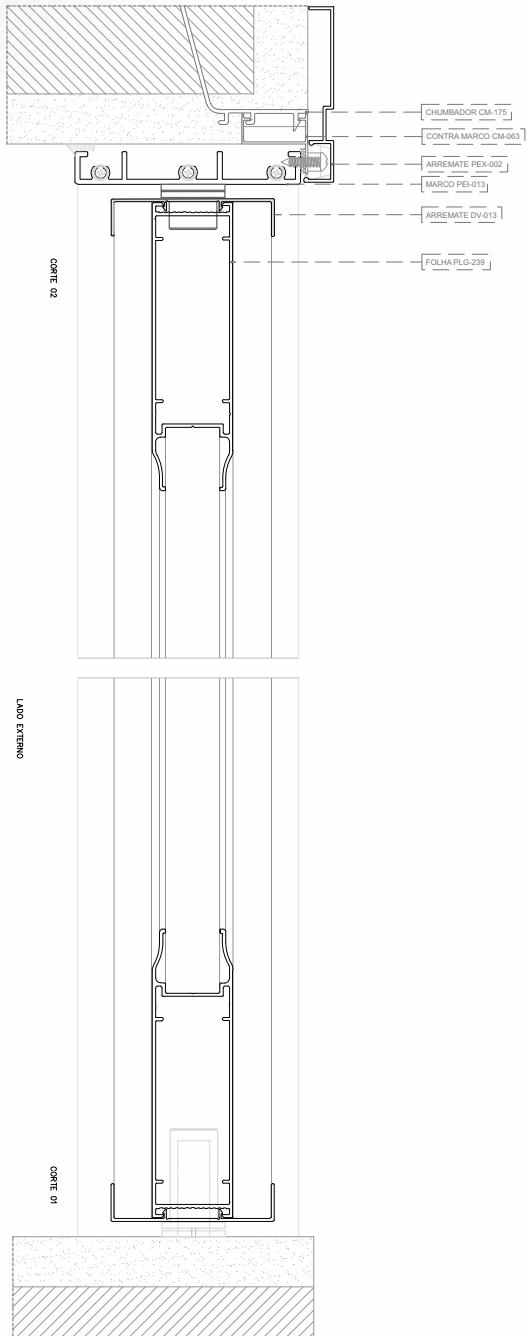

PORTA PIVOTANTE COM
REVESTIMENTO DE LAMBRI

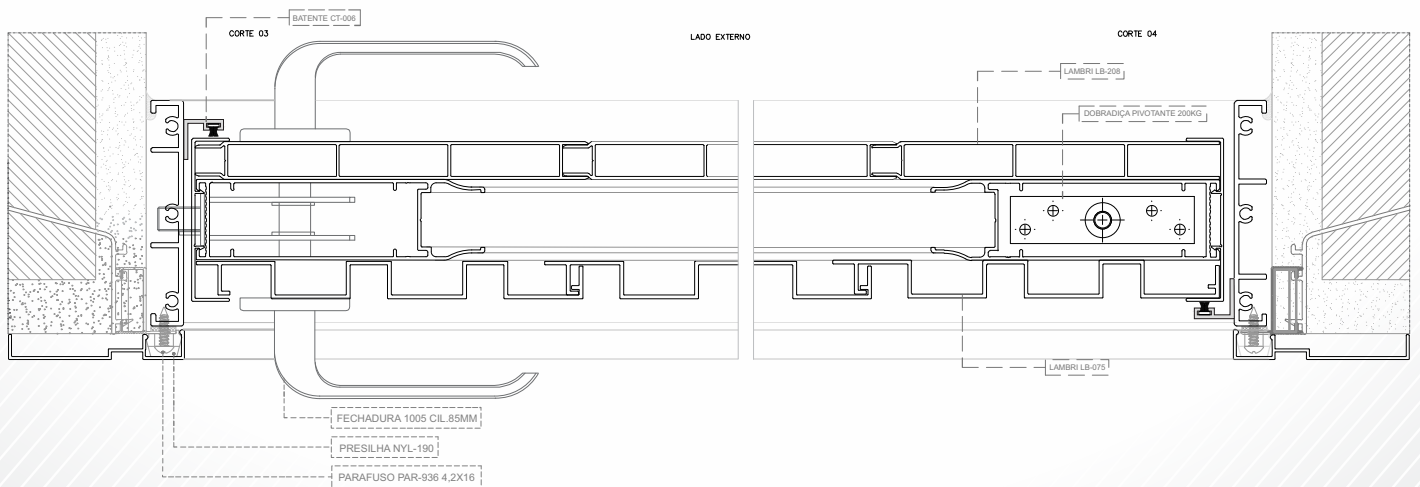
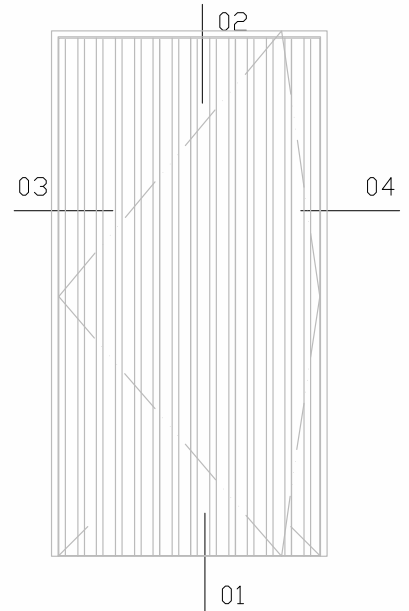

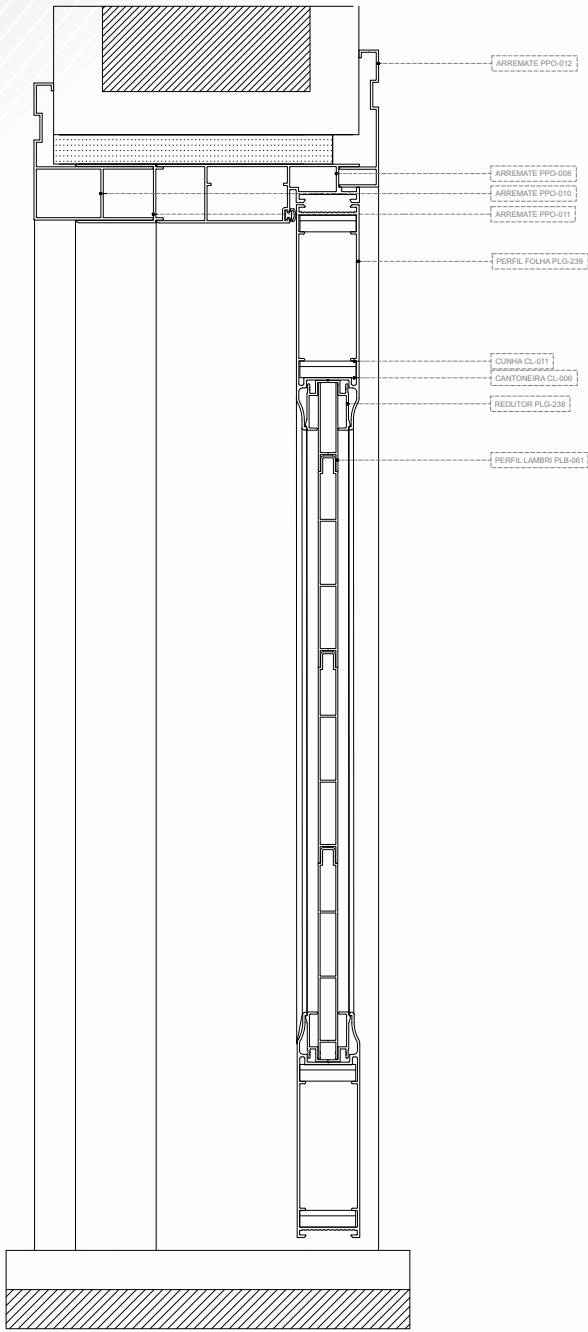

PORTA DE GIRO COM REDOR E LAMBRI

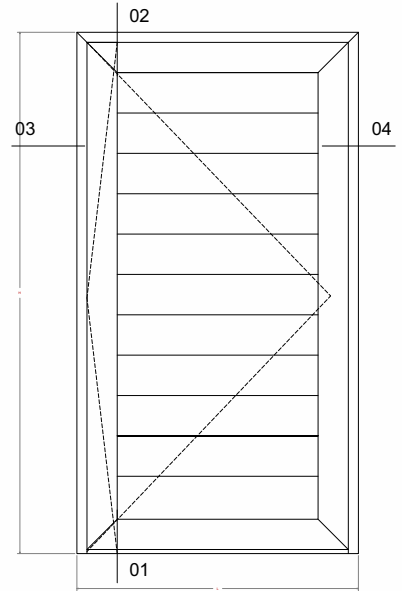

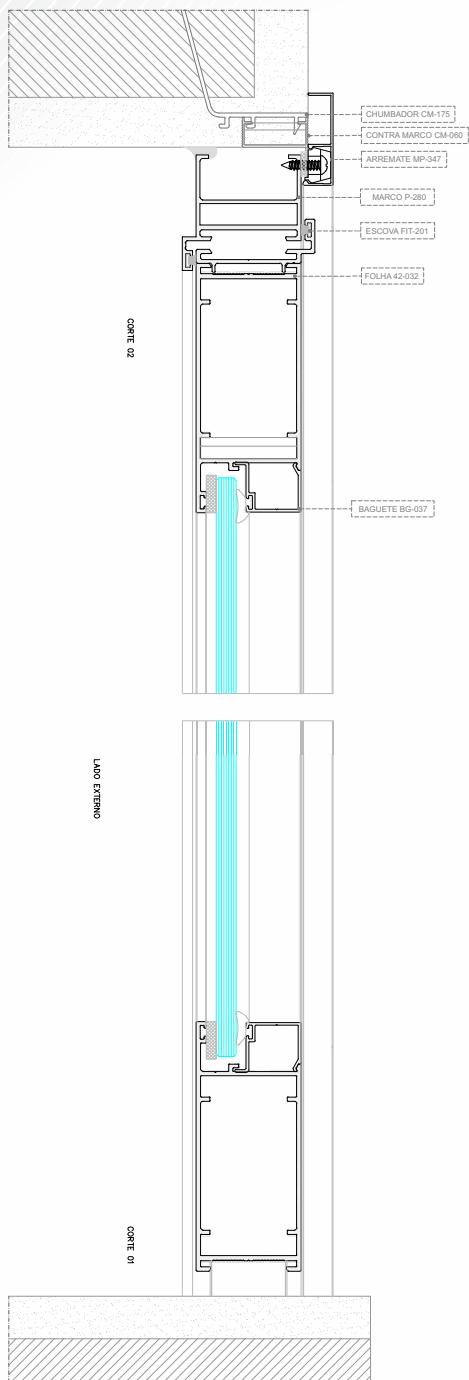

PORTA DE GIRO 1 FOLHA COM VIDRO

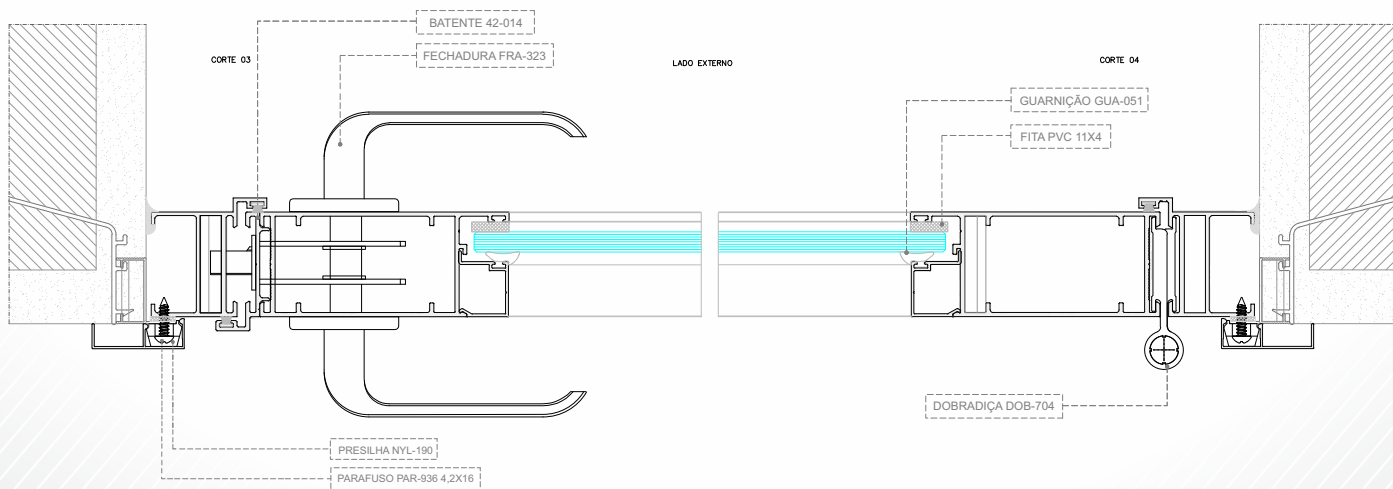
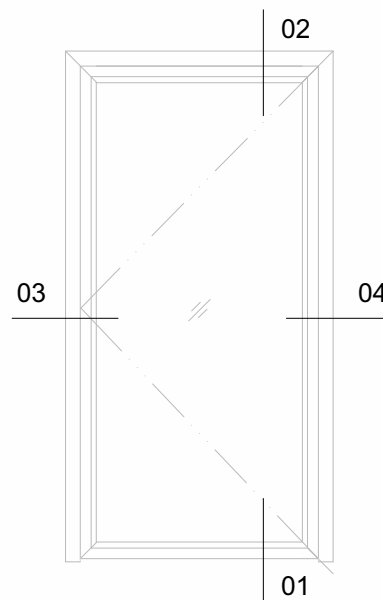

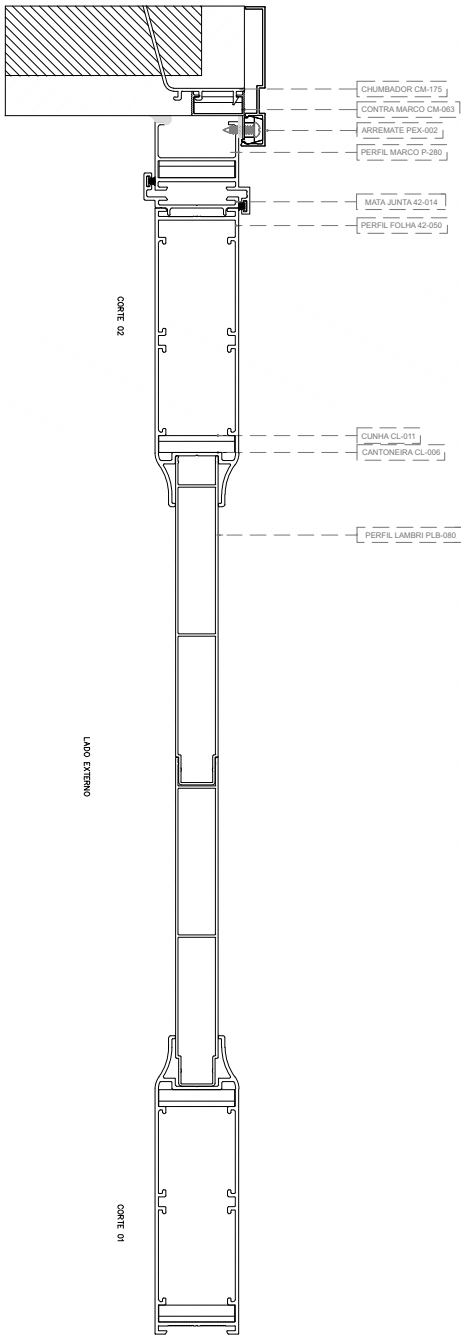

PORTA DE GIRO COM LAMBRI

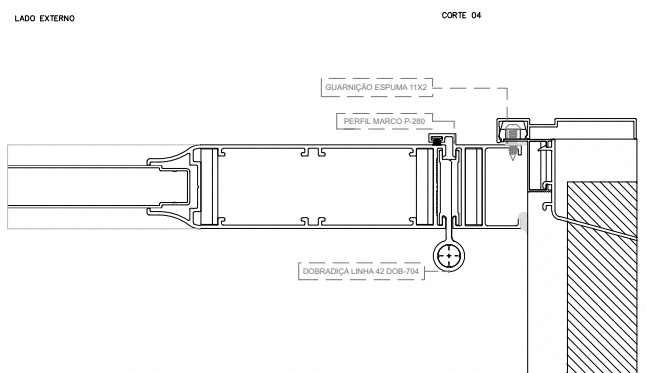
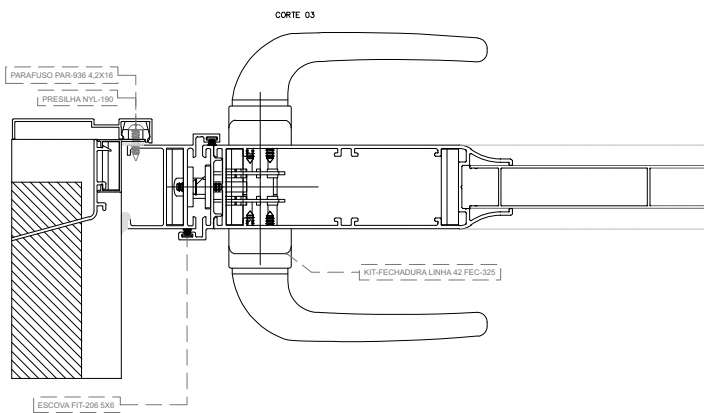
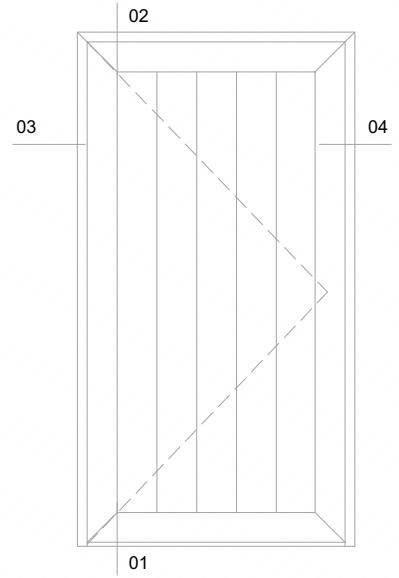

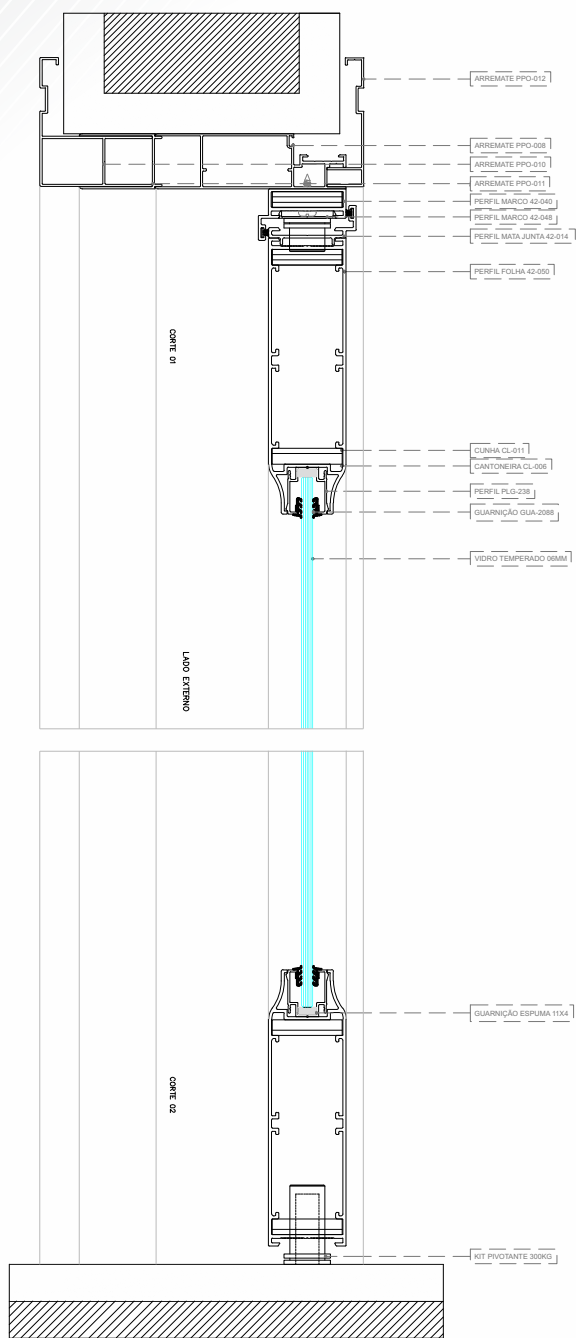

PORTA PIVOTANTE COM VIDRO

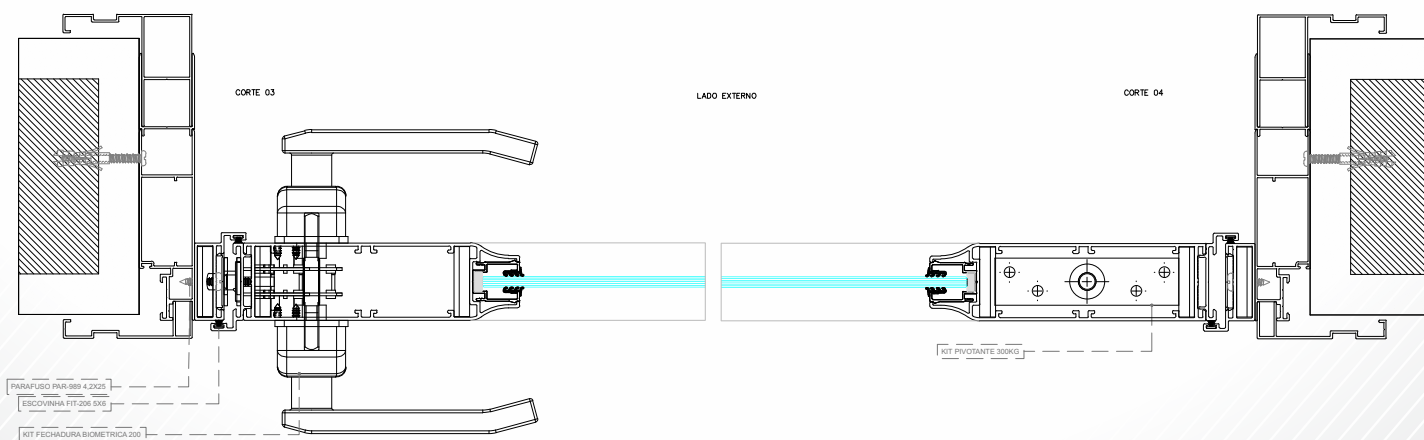
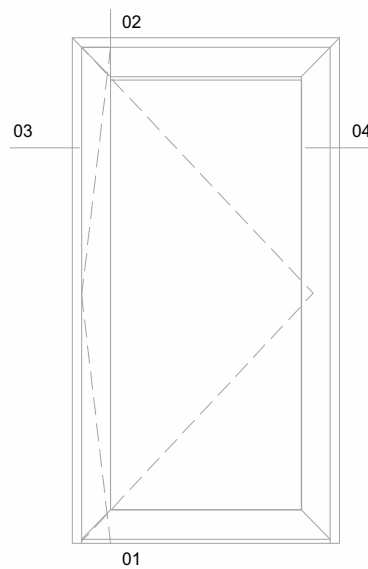

SUD

PERFISUD
EXTRUSÃO DE ALUMÍNIO

COLORSUD
TECNOLOGIA EM PINTURA

  @perfisud

Rodovia SC 370 – KM 170, S/N
Pouso Alto | Gravatal | SC
88735-000 | Brasil
+55 48 3628-0666

PERFISUD.COM.BR

